

Model Aeroplane  
Building  
sketch by sketch

Peter Holland

دانشگاه هوا و فضا  
دانشگاه صنعتی امیرکبیر

ARGUS BOOKS



Z B L 2 1 0 2

**Argus Books Limited  
Wolsey House  
Wolsey Road  
Hemel Hempstead  
Hertfordshire HP2 4SS  
England**

**First published by Argus Books 1987**

**© Argus Books Ltd 1987  
© All illustrations W. P. Holland**

**Reprinted 1988**

**All rights reserved. No part of this publication may  
reproduced in any form, by print, photography, microfilm  
or any other means without written permission from the  
publisher.**

**ISBN 0 85242 902 9**

**Phototypesetting by Photocomp Ltd., Birmingham  
Printed and bound by LR Printing Services Limited  
Manor Royal, Crawley, West Sussex, RH10 2QN**

**MODEL AEROPLANE  
BUILDING  
SKETCH BY SKETCH**

# Contents

	Page
Introduction	6
Chapter 1 Which materials, where?	7
Chapter 2 Building with sheet	17
Chapter 3 Profile fuselages	30
Chapter 4 Open frame models	35
Chapter 5 Mounting the engine	53
Chapter 6 Better fuselages	60
Chapter 7 Around the engine	72
Chapter 8 Hatches, cockpits	81
Chapter 9 Better wings and tails	89
Chapter 10 Hingeing control surfaces	100
Chapter 11 Wing and tail attachment	110
Chapter 12 Struts	115
Chapter 13 Landing gear (undercarriages)	120
Chapter 14 Snow and water	133
Chapter 15 Electric flight and CO <sub>2</sub>	138
Chapter 16 'Foam' construction	143
Chapter 17 More materials	150
Chapter 18 Covering and finishing	156
Chapter 19 Propellers for rubber power	164
Chapter 20 Linkage tips for R/C, C/L and F/F	170
Chapter 21 Rigging and checking	176
Chapter 22 Minor repairs	181
Chapter 23 Workshop tips	185

# Introduction

To those who really care, the building stage of a model aircraft is every bit as interesting and rewarding as its flight performance. Why be just a flier of models when you can have the pride of creating the machine from raw materials and accessories? Building model airframes (that's everything but the engine, wheels and control gear) is not difficult. The more you build, the easier it gets, so more advanced projects can be tackled.

This book takes the builder through construction stage by stage, covering the subject from the various aspects of aeromodelling, from free-flight, radio control and control line, via rubber power, gliders and power models, including electric power.

It shows the basic tried and tested forms of construction and provides hints on the methods used.

The 876 sketch details lead the modeller through from simple to more elaborate constructional forms, as befits different types of models and the use of different materials . . . The bare description of the book, written as above, only *sounds* technical . . . You are invited to dive in, via the sketches, and see how traditional aeromodelling construction has progressed since the 1930s, when balsa wood was first used, to the better ways of using that same material today. The latest techniques have ensured that aeromodelling has grown and grown, to further improve the art of flying reliably and efficiently. If *you* are not a contest enthusiast, the hints and tips will also help you to make a better job of that next model and later attempt machines which were apparently complicated.

Whether you build from plan designs (there is a vast range available in the Argus Specialist Publications range) or whether you start with kit models and progress to own designs, this book should be a constant reference. It can also aid a designer in the choice of construction and guide the unwary through hitherto unfamiliar forms of assembly.

Making things easier for yourself as you make that next model is really doing yourself a favour. Read and act upon the proved techniques in this book and the model you produce should do you a favour too!

# CHAPTER 1

## Which Materials, Where?

### Types of model Identification Basic woodworking

First let us find out what construction is needed for which type of model, and at the same time see just how many different classes of model are around for your enjoyment.

Rubber duration (sketch 1:1) needs ultra light construction, but the fuselage has to withstand the pull and twist of a powerful skein of rubber. 1:2 shows a duration glider which could be free flight or radio controlled and tow-launched. Strong wings with lightness needed here. Power duration is fast and precise in performance and needs to be carefully made; stiff and light (1:3). For fun flying, anything that is stable and controllable, and takes the owner's fancy, can be classed as a sport model. 1:4 shows a pseudo 'jet' liner (actually driven by a propeller in a slot).

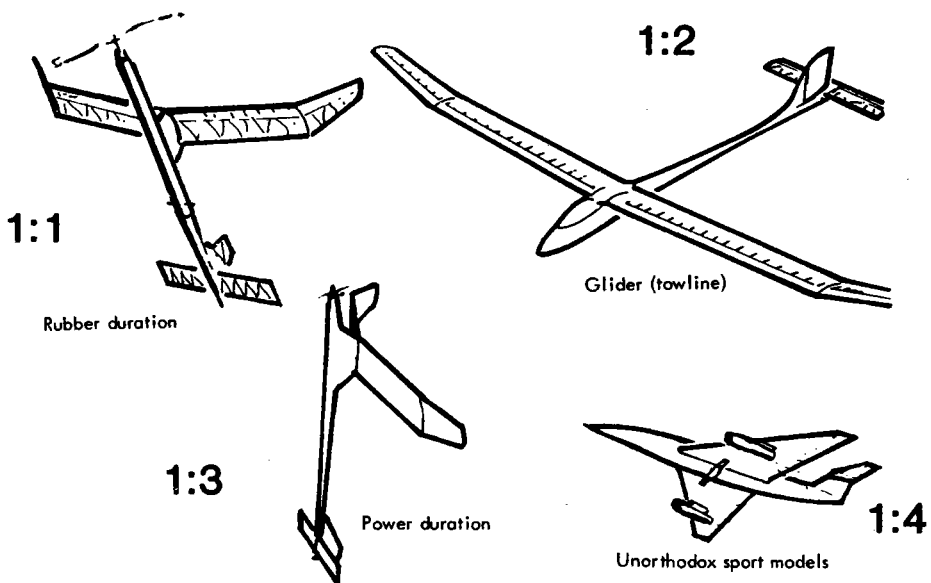

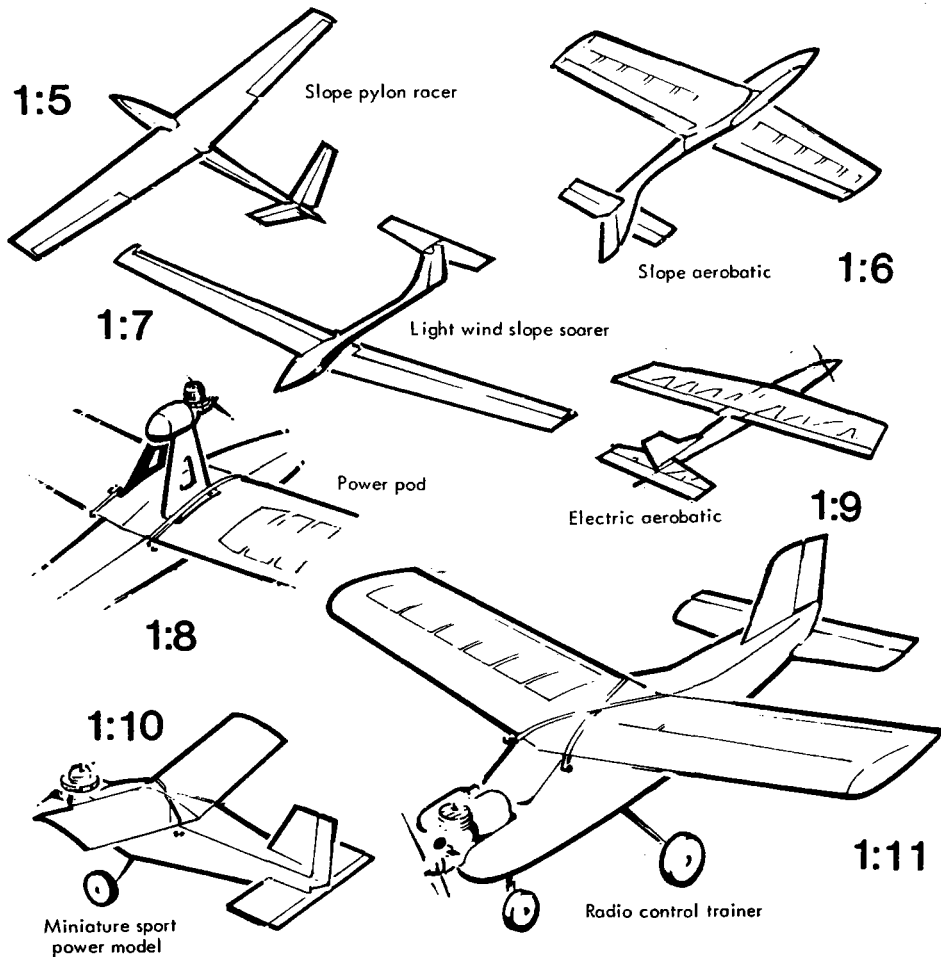

Radio control is the rule rather than the exception in these days of restricted areas for flying. The gliders on this page are for soaring from breezy slopes. 1:5 is a racer and has thin wings for speed, often fully sheeted over. For more fun, the lighter aerobatic model (1:6) has rudder, aileron and elevator controls and short wingspan. On less breezy days, slope enthusiasts can use larger slower models with duration the aim, as in 1:7.

Gliders can be helped aloft from flat fields by use of a fixed or removable 'power pod'. This carries a small diesel or glowplug engine, often above the balance point (C.G.) of the model. Its purpose is to give the glider a gentle climb, instead of a tow-launch. Needless to say, the model then needs to be fuel proofed properly and strengthened where the power pod is to be fixed. A hybrid is the electric powered glider, which needs a light airframe to allow for battery weight, and the sports or aerobatic electric model with similar constructional considerations (1:9). Power models flown for sport can be simple sheet knockabouts like 1:10, or large and carry radio control for training purposes (1:11).

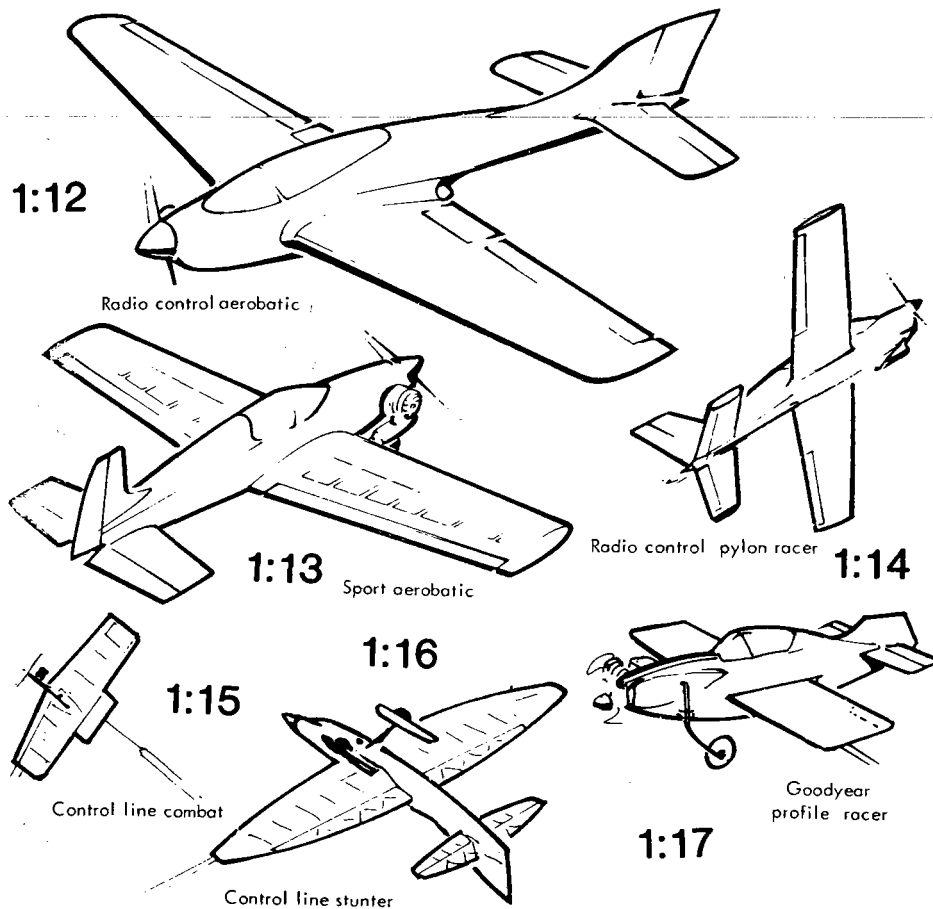

When you know how to fly radio control models really well, the subject can be more elaborate. Indeed, with standard balsa and kindred constructional materials, almost any shape can be built – as building skills progress. A contest aerobatic machine in the class of 1:12 would be fully skinned, light, stiff and cleanly shaped, having a retractable undercarriage and internal silencer system.

Sport aerobatic radio control models can be made to look less functional and more scale-like, although easy access to the engine is often considered more important than good looks, see 1:13.

Such an airframe might be used for control-line flying, if scaled down. Pylon racers too (1:14) need to be really tough, the popular size is for .20cu. in. engines. Fully sheeted structures these, some with glassfibre fuselages.

Control-line models vary in construction from light open frame combat models as in 1:15 and elaborate light structures for high performance stunts as seen at 1:16, to a simple profile fuselage as seen in the 'Goodyear' class of control line racer in 1:17. Beginners' models can be almost entirely flat sheet.



## Identity parade

Let's name the basic parts of a model, so that what follows will be clearer. Sketch 1:18 gives the basics for a radio control trainer, but the general arrangement can well apply to almost any subject. Reference is made to the basic airframe; other components like undercarriage (landing gear) will be dealt with in later chapters.

This book does not attempt to describe the design of a model from an aerodynamic point of view, but the construction, in relation to the part it plays in a particular model, is important, so we have to identify, for example, wings that need strong construction from those which can be lightly made. 1:19 shows how to identify the proportions of the wing (or tail). Low aspect ratio would be short span, wide chord, high aspect ratio long span, narrow chord.

The wing section (aerofoil) of which a selection appears in 1:20 may now be identified.

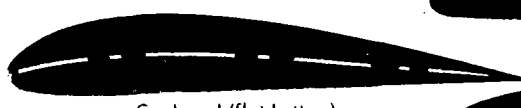
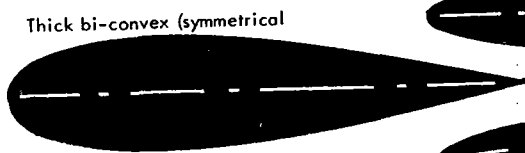
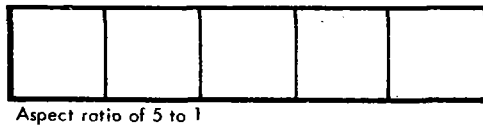
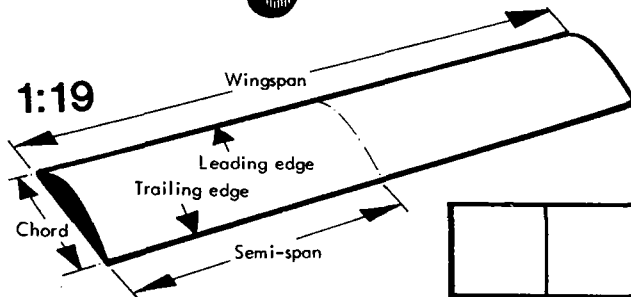
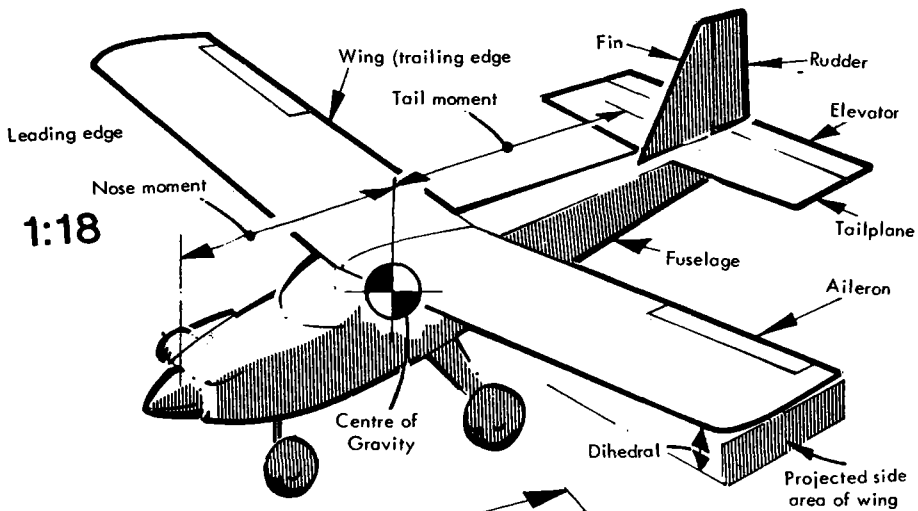

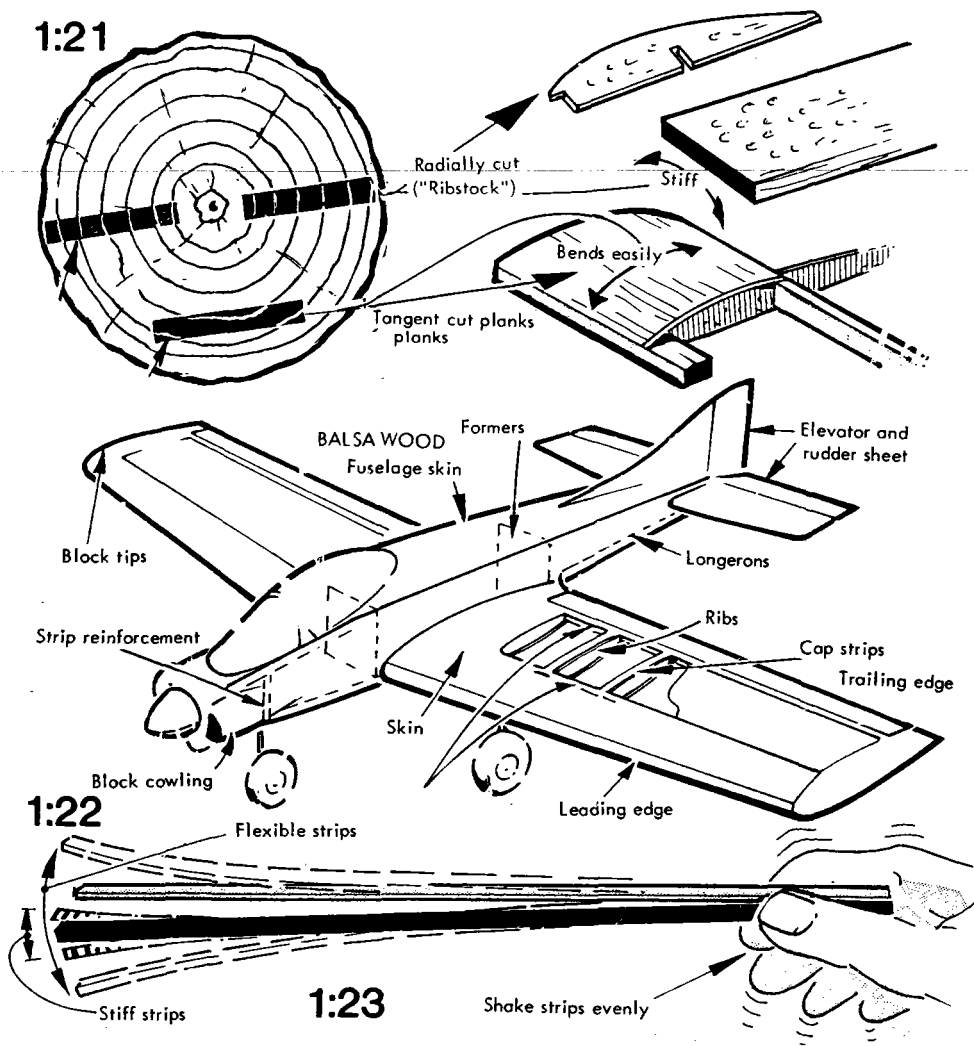

## Timber!

Balsa wood is the traditional material, light, easily worked and available from model shops that specialise in model aircraft supplies. Sketch 1:21 shows how the basic material in sheet form is cut from different areas of a tree trunk. *Tangent* cuts yield sheets which are easy to curl across their grain, for use in sheet skinning over wings and rolling into tubes. Sheets cut *radially* (across the rings of growth) can be used for ribs and other parts which need to be stiffer across the width of the sheet. Most sheet is sold in 36in. lengths but some shops stock 48in. sheet. 1:22 shows in how many places balsa forms the structure. In this example most of it is sheet: thick for the fuselage sides, thin for the wing skins which reinforce a sheet and strip framework. Often, the tail surfaces are thick sheet, but areas like the wingtips and engine cowling are soft blocks of balsa, or thick sheet laminated. Strip balsa varies in strength, so careful matching of strips for like duty is important. 1:23 shows one way of testing, but be careful in the shop. No shopkeeper wants broken bits! Check it at home from your stock of strip.

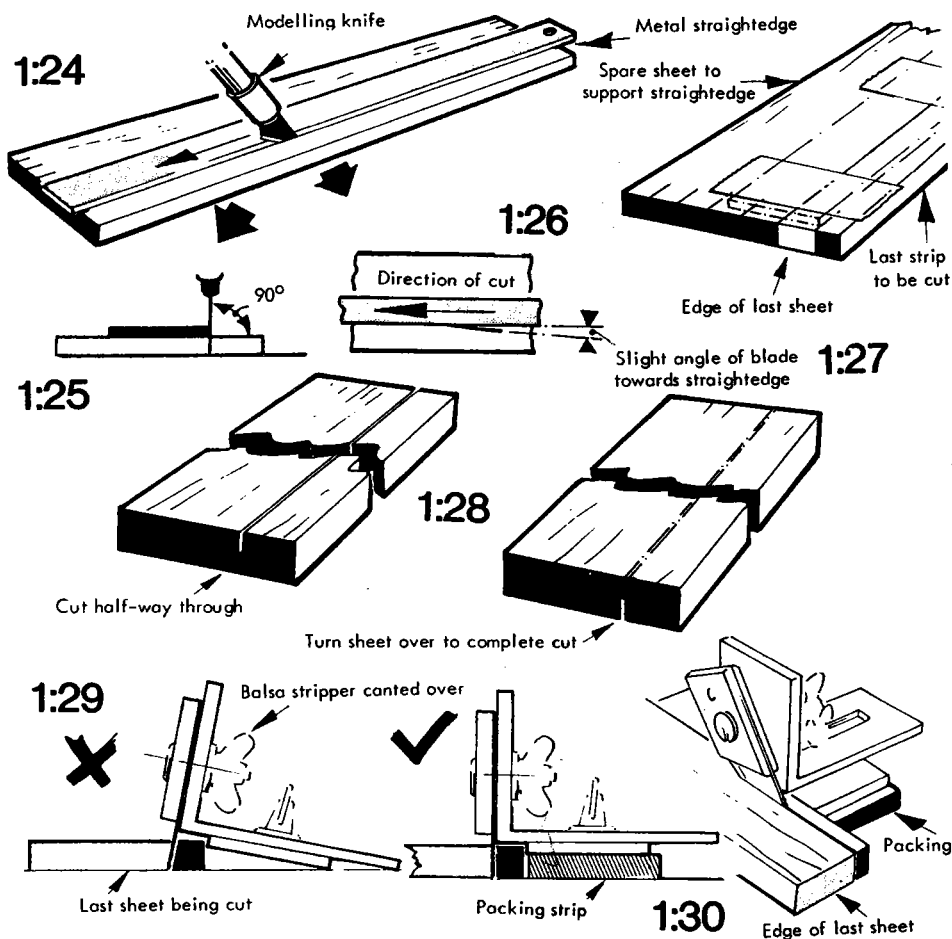

### Strip from sheet

Another way of making sure strips are similar in strength is to cut them from the same sheet of balsa, with the aid of a metal straight-edge to guide the modelling knife as seen in 1:24. Do not allow the blade to wander into the strip being cut, but try to follow what is shown in 1:25 and 1:26. As the sheet is used up, the straight-edge will rock and the sheet will slip. To avoid this, glue glass paper patches under the straight-edge to grip the wood and lay a piece of sheet behind the remains of the one being cut, to support it, as in 1:27 – a few pieces of Sellotape help to stop movement of the sheet remnant.

Thick sheet will be difficult to strip accurately. Do not try to cut it in one stroke but make several passes with the blade upright, turn the sheet over and cut to meet the first cut. The strip should be flat on its cut edge . . . practice makes perfect (see 1:28).

Commercial balsa strippers may be used, but make sure that they are held level, otherwise the strip produced will be chamfered, as shown in 1:29. However, if a strip of thinner wood is placed under the stripper or taped to it, the blade should remain upright as in 1:30.

Large section strip or sheet can be planed with a modelling plane. Hold it at a slight angle as in 1:31 to get a clean slicing action. Balsa sands so easily that home-made sanding and shaping tools can be made as in 1:32, for working odd corners.

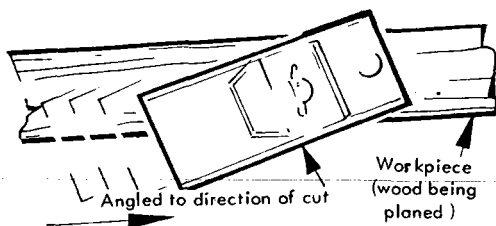

1:31

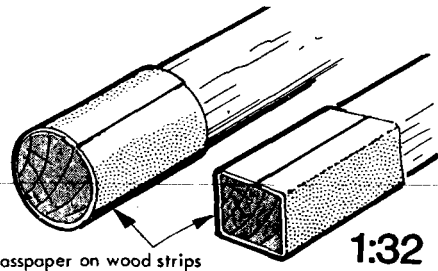

1:32

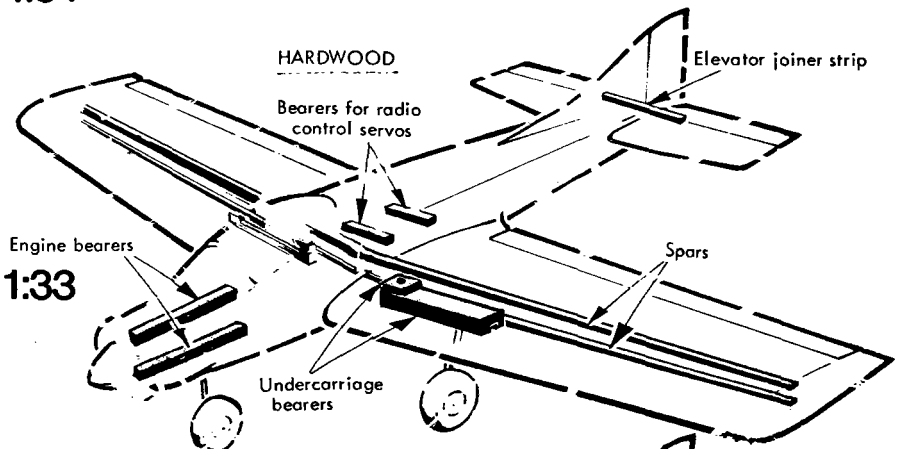

1:33

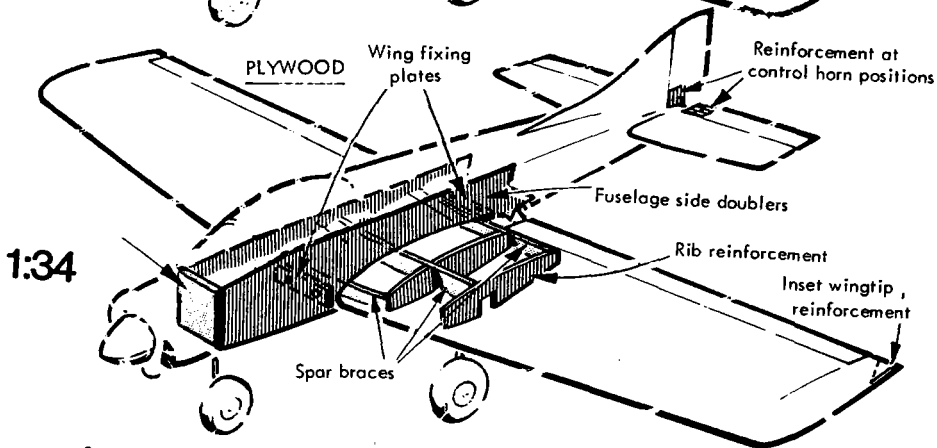

1:34

### Hardwood

The correct botanical term for balsa is 'hardwood', although it is anything but hard. Conversely, what the woodyard salesman calls 'softwood' is, to us, hard. It has been thus for many years, so we must continue in this book.

Hardwood, as far as the model is concerned, is spruce or pine for light strong spars and other strip structure. 'Proper' hardwoods like beech are used for mounting the engine and at other points where high stresses are present, and where components may be bolted on. It is too heavy for use in large quantities. Sketch 1:33 shows where it may be needed, together with spruce for those spars.

### Plywood

The lightest 'gaboon' plywood (from woodyards) is fine for areas where thin ply is specified, such as some fuselage formers, but a high quality birch ply is best for highly stressed parts like an engine bulkhead on a larger model, wing braces and in thin sheets for

strengthening (doublers). Model shops sell ply down to  $\frac{1}{64}$ in. thick – it may be rolled into tubular fuselages or used sparingly on 'light-weights'. Some ply has a thicker centre lamination: choose this where a part has to be equally stiff in both directions (compare 1:35 and 1:36, which shows the latter).

### Cutting ply

Thin ply is best cut with a knife on a piece of hardwood or hardboard (1:37). Thicker ply can be sawn, provided the edge is supported close to the sawcut, as in 1:38, otherwise it may have a ragged edge.

Cut into, or out of holes, at the corners when removing areas from the centre of, say, a former. A weak point occurs if knife-cuts cross. 1:39 shows the method and 1:40 an alternative if you have woodworking chisels and gouges. Just press hard with a sideways rocking action to help the chisel to cut. Generally speaking, ply up to and including  $\frac{1}{16}$ in. thick can be cut with a knife and  $\frac{1}{32}$  and  $\frac{1}{64}$ in. can be cut with sharp scissors, provided the shapes are not intricate.

Thicker shapes are best sawn with a fine-tooth saw or a hacksaw blade, or on a fretsaw (if the shapes are complex).

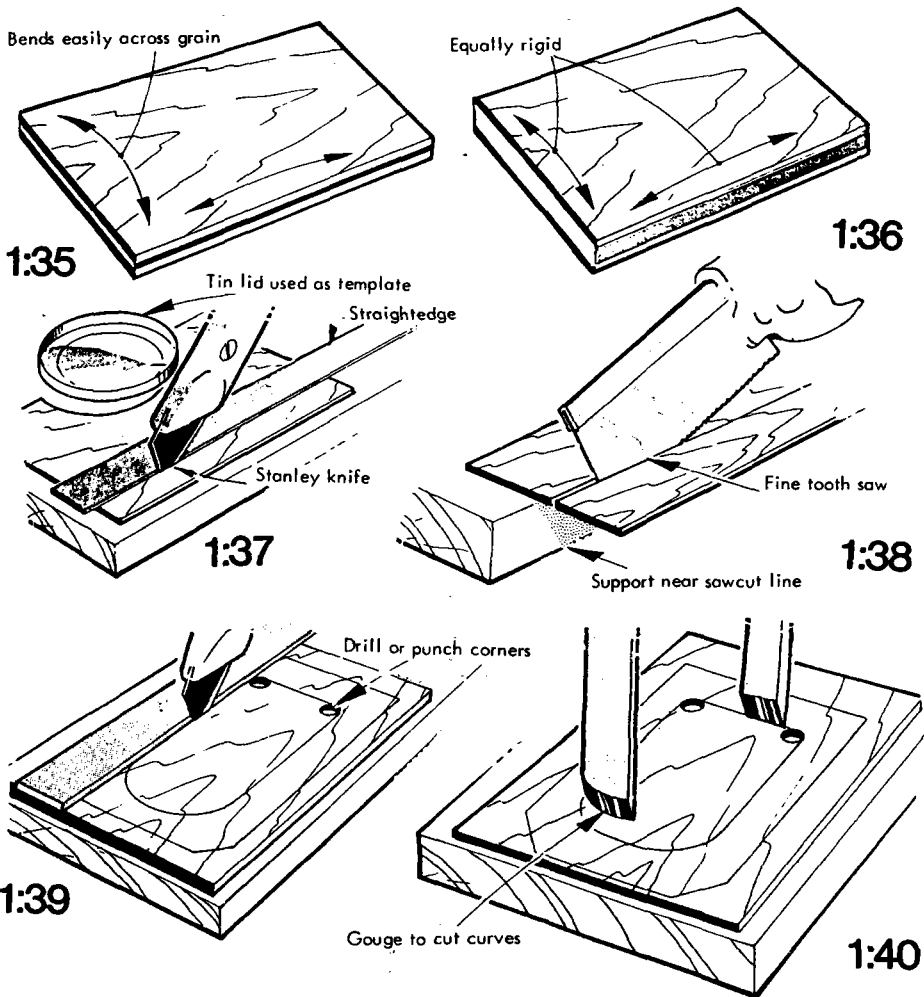

Tidying up cut edges is best done by stroking from edge to centre of edge as in 1:41, using a file or glasspaper on a block. A really sharp plane set fine is permissible for thick ply on straight runs.

### Stock balsa sections

Your model shop may have a wide range of pre-cut strip balsa, in some cases more than those shown in sketch 1:42. These typical sections are the most popular; strip is cut in sizes from  $\frac{1}{16}$ in. square up to  $\frac{1}{2}$ in. square, and rectangular strip from  $\frac{1}{16}$ in. x  $\frac{1}{8}$ in. and in like proportions up to 1in. x  $\frac{1}{2}$ in.. Dowel (round) is not always available but is not so widely used. The pre-shaped leading and trailing edges are sold in sizes from  $\frac{3}{8}$ in. to  $\frac{5}{8}$ in. and trailing edge from  $\frac{1}{8}$ in. x  $\frac{1}{2}$ in. up to 2in. x  $\frac{1}{2}$ in. Sheet comes in thicknesses from  $\frac{1}{32}$ in. up to  $\frac{5}{8}$ in. and in widths of 2in., 3in., 4in., and even 6in.. If a component is to be of uniform strength, avoid sheet which is soft on one edge and hard on the opposite one. Such wood is best reserved for small components, when they may be placed where the sheet offers the appropriate density.

### Adhesives

PVA white glue is most popular, but the standard woodworking variety does leave a rubbery ridge at the joint edge when sanded, so choose a 'sandable' type for the exposed areas. Small bottles are easier to handle, but fill them up from the economy size bottle. If the spout is too large, giving large globules of glue, add a small tube to the tip as in 1:43. Balsa cement, much favoured some years ago, is a solvent based adhesive, dries quickly and sands easily. It is still used on the lighter free-flight models by some. Cyanoacrylate (Superglue) is fast for

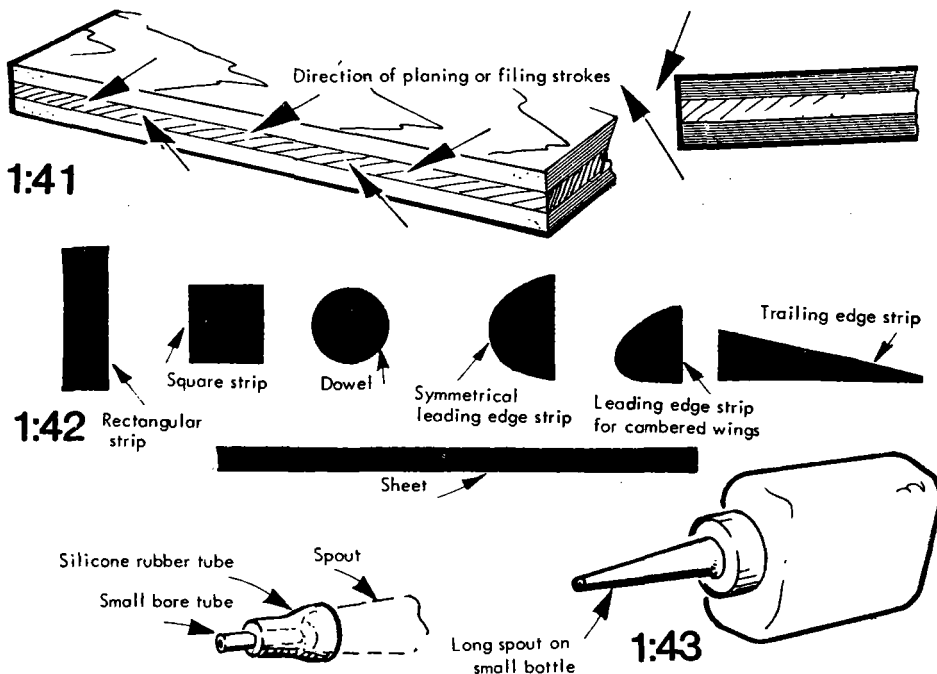

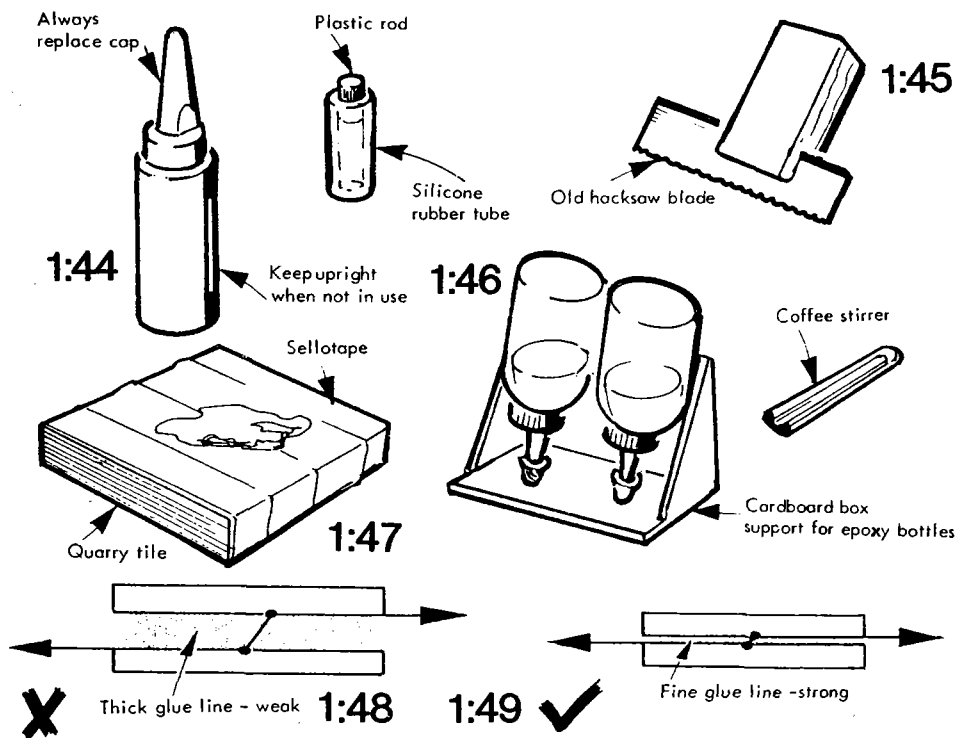

construction and may be considered worth the extra cost (look at the time saved). Place components together and spot the glue on to be drawn in by capillary action. If the cap gets clogged, make a new one as in 1:44.

Plywood doublers and even large areas of sheet, used for this purpose are best fixed with contact adhesive. Spreading this can be wasteful, so use a fine serrated edge like a discarded piece of hacksaw blade in a wood block (1:45).

Fast epoxy (five minute working time) is also popular, but adds weight. The type in twin bottles is convenient, with long spouts, but the liquids tend to be sluggish in reaching the spout, when inverting them for use. Provided the caps are secure, they can be kept inverted between use by propping them up in a cut-down cardboard box, as shown in 1:46. The adhesive can be spread or transferred with any scrap of balsa, lolly stick or spill of card, but old plastic stirrers from coffee machines have a groove in the handle, which holds extra adhesive. The epoxy can be mixed on a few strips of masking tape on the edge of the work table. The tape can be discarded when it becomes covered with cured epoxy. Never mix up more than can be applied in five minutes. In hot weather, it pays to have a few quarry tiles or other thick ceramic or metal blocks in the refrigerator. Sellotaping their surface before cooling them makes a mixing area and the cooling effect prevents the epoxy setting too quickly, before it gets to the joint. (1:47) If epoxy is warmed *in* the joint, it will flow easily . . . Make that glue line thin! (1:48)

In the following chapters you can get 'stuck into' some actual building . . .

# CHAPTER 2

## Building with sheet

Cutting out  
Double crutch fuselages  
Wings  
Tails

See also  
Chapters 1, 5 and 6

This is the start of actually putting models together. Sheet balsa construction is examined as the basis for further details in following chapters.

First to mark out shapes of components onto the wood, a favourite method, in the absence of stick-on templates or printed wood, is to carbon down from the drawing, or prick around the outline with a blunt pin, as in sketch 2:1. Why blunt? Balsa is so soft that the grain closes up easily, so a blunt pin leaves a better mark. For straight edges, it is only necessary to mark at the corners, then with the plan removed, place a steel rule from point to point and cut.

Curves can be drawn, using the pinholes as a guide, then cut so that the grain tends to draw the knife blade away from the component as in 2:2. If the knife is used in the opposite direction, it may accidentally run into the component and split it, as 2:3 shows.

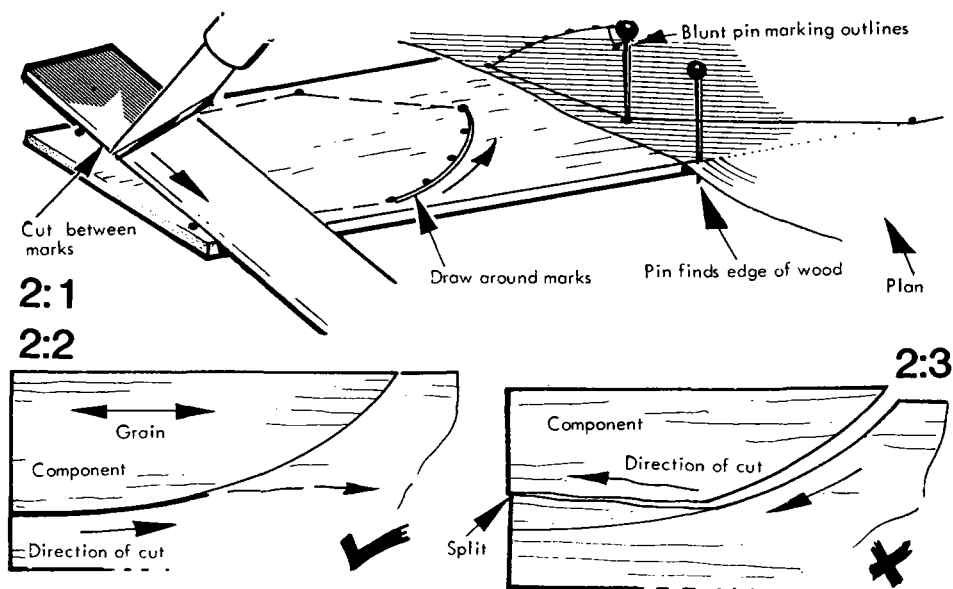

دانشکده هوا و فضا  
دانشگاه صنعتی امیرکبیر



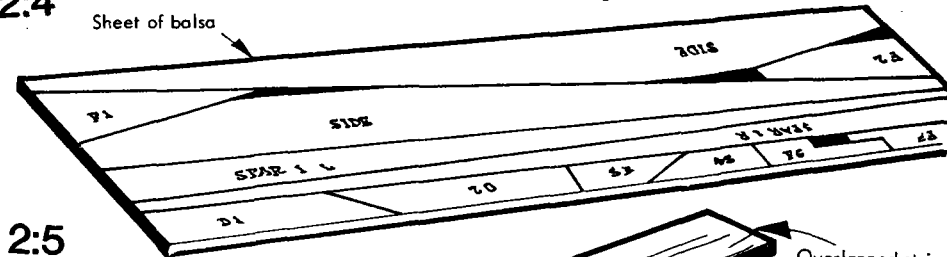
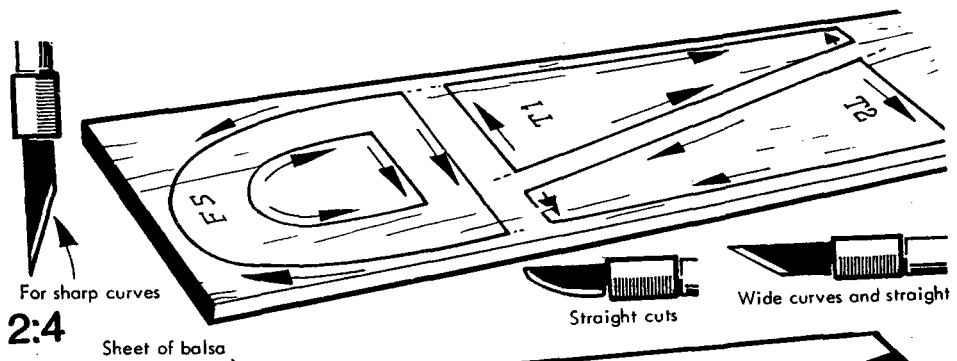

Doublers on formers with grain across

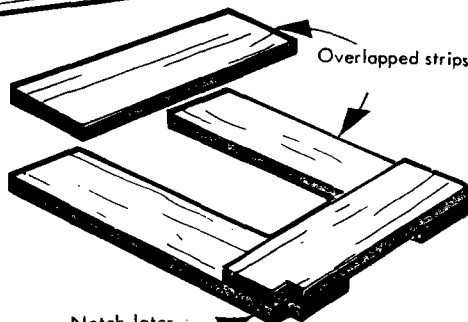
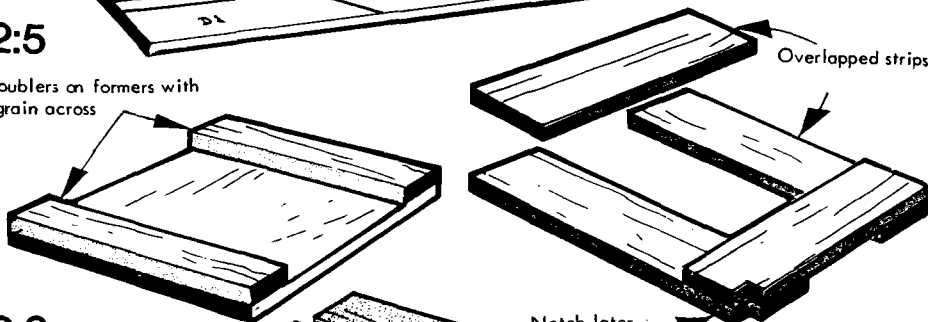

2:6

Notch later

2:8

Fillers fit between overlapped strips

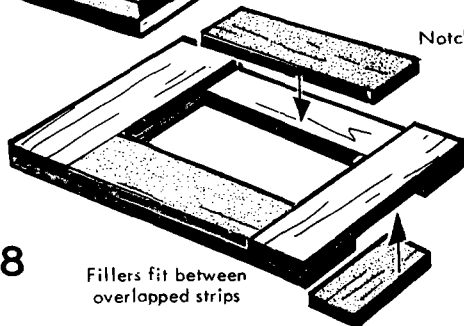

Although complicated shapes like those in 2:4 may not be dealt with in this chapter, the arrows indicate the better direction in which to cut. Sharp curves are best dealt with by using a sharp pointed blade, long straight cuts with a curved one (for long blade life) and gentle curves with a less pointed blade.

By laying part shapes out carefully, they can sometimes be cut using a common line, leaving very little waste wood. Take care, though, that the parts all lie with the correct grain direction. See the fictional layout of 2:5.

In connection with the construction of fuselages, our first exercise in this chapter, some formers will be needed. These may be plain rectangles of sheet, or reinforced as in 2:6 by adding strips of balsa along the short grain edges. They may also be assembled from rectangular strips as in 2:7, leaving an access hole in the centre. It is of little importance that the top and bottom are not flush, in fact it makes

the corners strong and provides more joint area for other parts of the structure. Fillers can be added as in 2:8.

### Cross crutch

The simple fuselage in 2:9 uses a 'side profile' shaped sheet of balsa, say  $\frac{1}{16}$ in. thick for small models, up to  $\frac{3}{16}$ in. thick for those of say, 5ft. wingspan.

The profile is made rigid by a second one in *plan* view, cut to fit each side, and small gusset shaped formers, all as seen in 2:10. The resultant cross section at the wing is as 2:11 and further aft as 2:12.

The fuselage depends on the covering (doped tissue, nylon or shrink film) to resist torsional movement (twisting), but the edges of the sheet can be capped as in 2:13, to aid covering and stiffen the edges.

Normally, the covering will shrink in to produce interesting concave shapes at the front and rear of the wing mount or pylon, but soft balsa block can be placed here as in 2:14 and near the nose to reinforce the engine mounting. Alternatively the blocks can be restricted to the more sharply curved areas and sheet bent to fill-in or support an acetate windscreen, as seen in sketch 2:15.

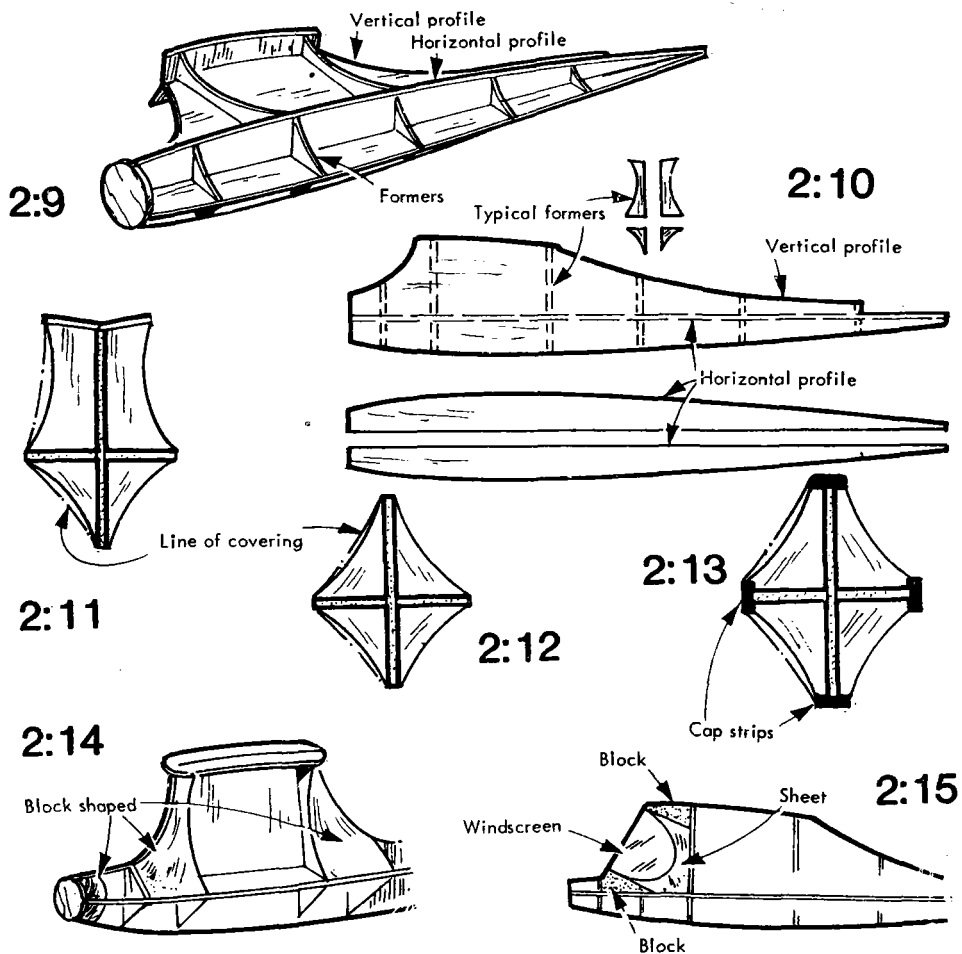

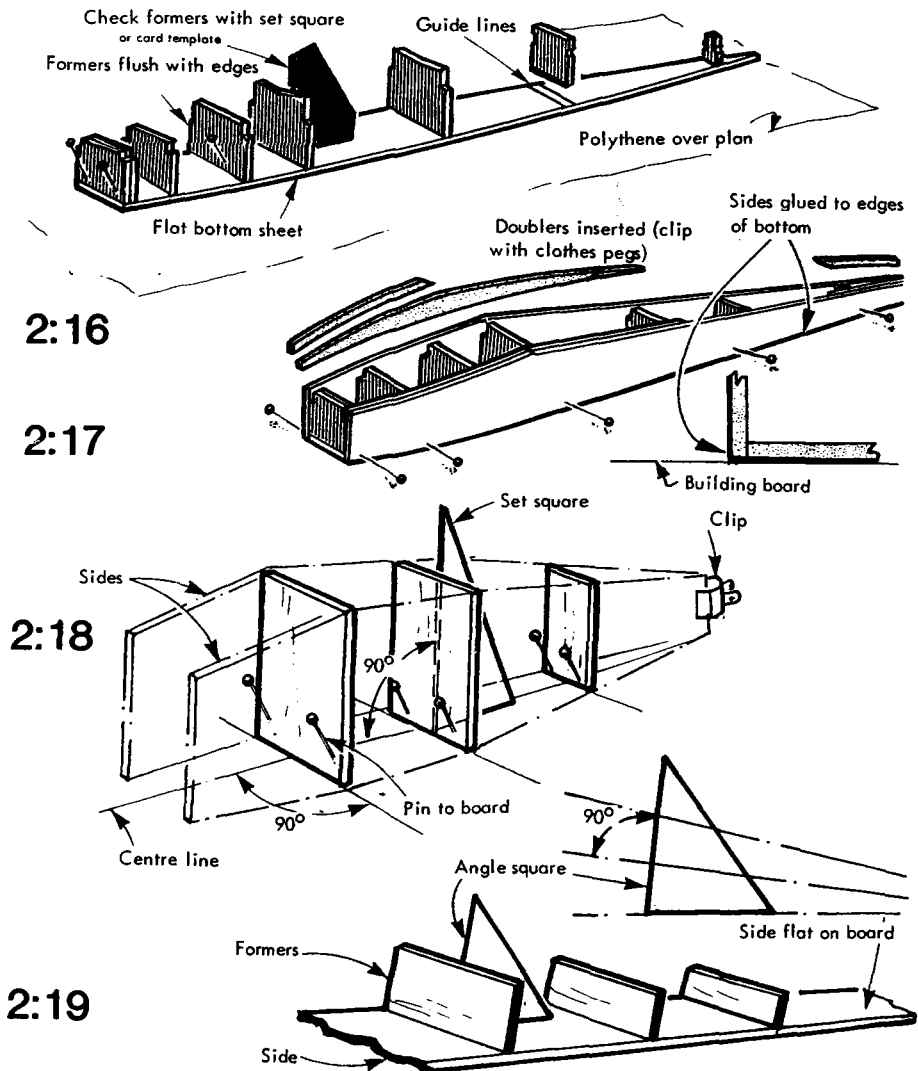

### Box fuselages

If the fuselage has a flat bottom, that sheet, cut and pinned to a flat board, can be the basis of construction. Mark the positions of each former and pin and glue them in place vertically, checking with a small triangle of card or a matchbox (2:16) The pins are withdrawn when the glue is set, then sides added, as 2:17. If the sides overlap the bottom sheet, they should be set down onto the polythene covering the board or plan. If there are any reinforcing strips or 'doubblers' they go in at this time. A fuselage with a flat top can be built in an inverted position. The foregoing pre-supposes that the formers are at 90° to the top in the latter example, or bottom in the former description.

If the sides are the prime structural members, position them vertically about a centre line, checking that the formers are vertical and at 90° to that line. See sketch 2:18. If the formers are added to one fuselage side laid flat on the board, beware . . . this tempting method is only good for those parts which are a straight taper to the tail or parallel

all the way. Use a card template shaped to the true angle between former and side as in 2:19.

If sides are assembled as in 2:20, placing the formers vertical in relation to one side, they will all be at the wrong angle. As a precaution, mark both sides whilst they are clipped together, at each former position as seen in 2:21. Then they can be assembled while the glue is still soft and the formers checked at each position, on both sheets as in 2:22.

Carrying this system further, notches may be cut in the top and bottom edges of the sides, to accept small lugs in each former, thus effectively locking them in the correct position, as in 2:23. The fuselage can be assembled upright, or on its side with packing blocks at nose and tail to keep it true. It is best, however to mark centre lines in each former and align them on one drawn on the board.

The grain direction on the formers should really be from side to side, so that the lugs are strong, as in 2:24, otherwise they may break off either while cutting them, or on assembly with the sides (2:25).

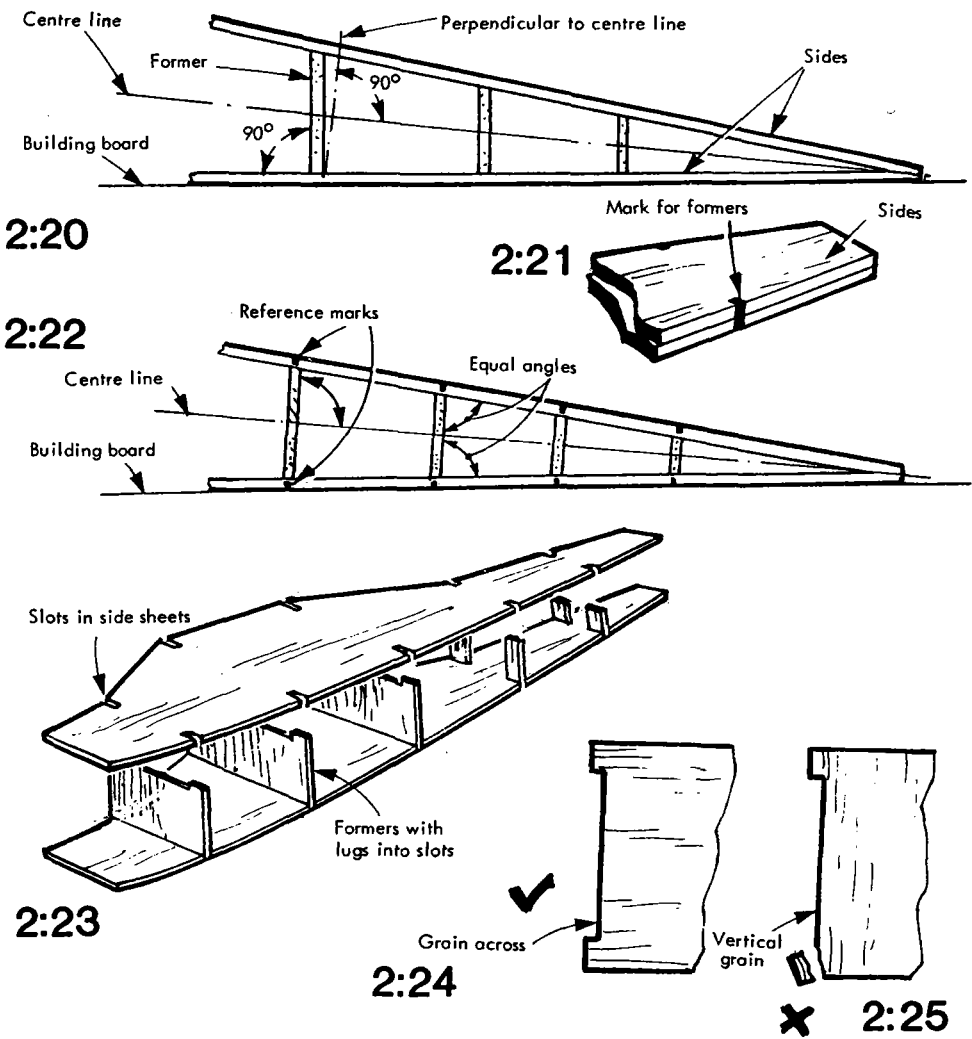

Doubler strips can also serve as lugs for this type of construction, resulting in a stronger former, as 2:26.

As a general rule, sheet fuselages, which have all four faces solid, fall into two categories: the first of which have thicker sheet on the sides than on top and bottom, as seen in sketch section 2:27. In this case, the top and bottom sheet can have the grain running across the fuselage, to add strength to the sides, or lengthwise. Alternatively the top and bottom sheet can be thicker than the sides as in 2:28, in which case all sheets have lengthwise grain. The top and bottom may be rounded off slightly to improve the appearance, but excess thinning at the edges may occur, unless a reference line is drawn on the edge of the thick sheet, as 2:29. This will show up as the sanding proceeds, whereupon the sanding is halted. Corners may be reinforced with a square strip as in 2:30. This increases gluing area, so thinner sheet may be chosen (note the cross grain top.)

On a glider, the sides can be terminated in a laminated noseblock; 2:31 shows grain direction. It can be stepped to take the sides as in 2:32, or the sides overlapped and blended in as in 2:33.

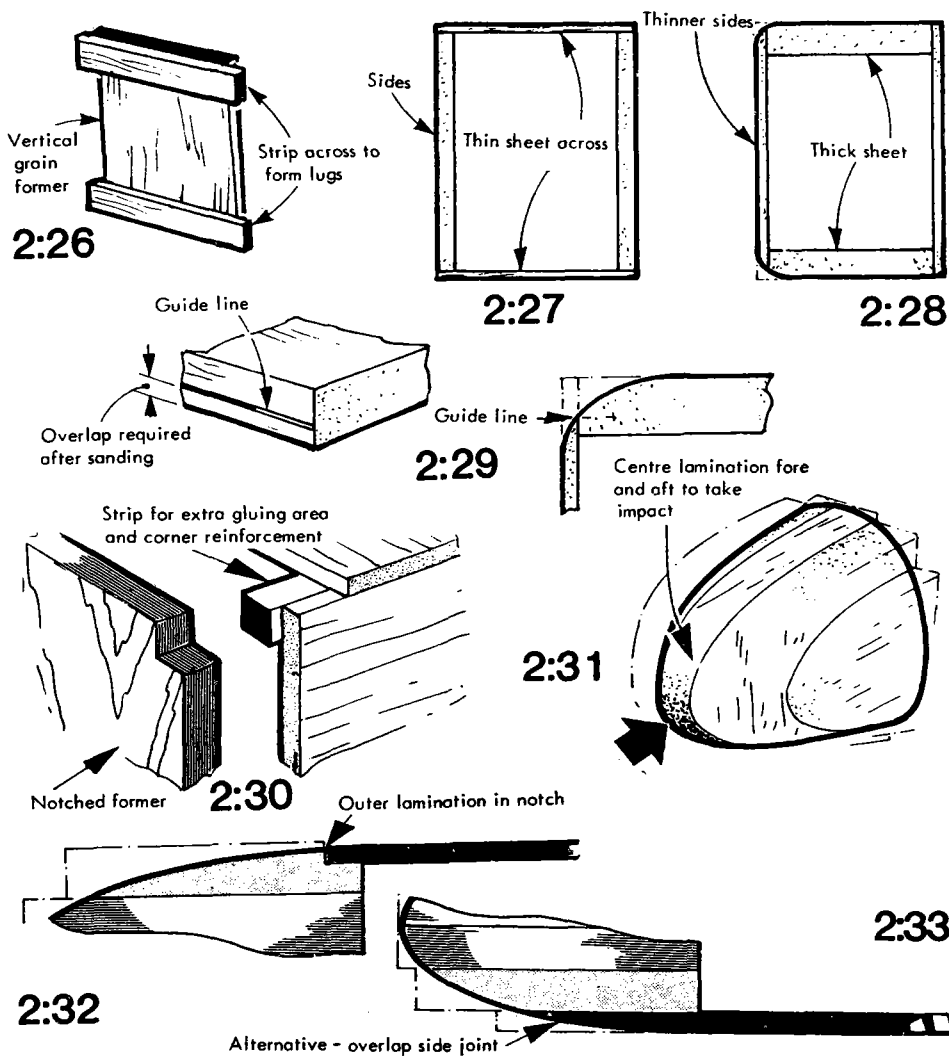

If long thin fuselages or tail booms are bound to secure them while the glue sets, avoid making a single binding as seen in 2:34. Two bindings done alternately for a couple of turns each should equalise the twisting force as in 2:35.

### Solid wings

The smallest of models can be allowed to get away with thin flat unshaped wing cross section, but for a better performance give it some camber, by sanding the top surface as in 2:36. Larger models can use thicker sheet, preferably with a joint, so that the leading edge is hard and the rest soft. This is strong and light and seen in 2:37. Conversely, sport models still fly quite well with plain flat sheet wings, rounded off slightly at the edges. It is the need for strength that dictates thicker material, which in turn will be better if shaped to a reasonable aerofoil section. More accuracy can be achieved by laminating two sheets of balsa, each sanded as seen in 2:38 for a cambered section or as 2:39 for a symmetrical one. The dimensions are only for comparison as are the sections resulting in 2:40. The edges of a sheet can be marked clearly as a guide to sanding, first on a flat board, then on packing when turned over for the second sanding (2:41 and 42).

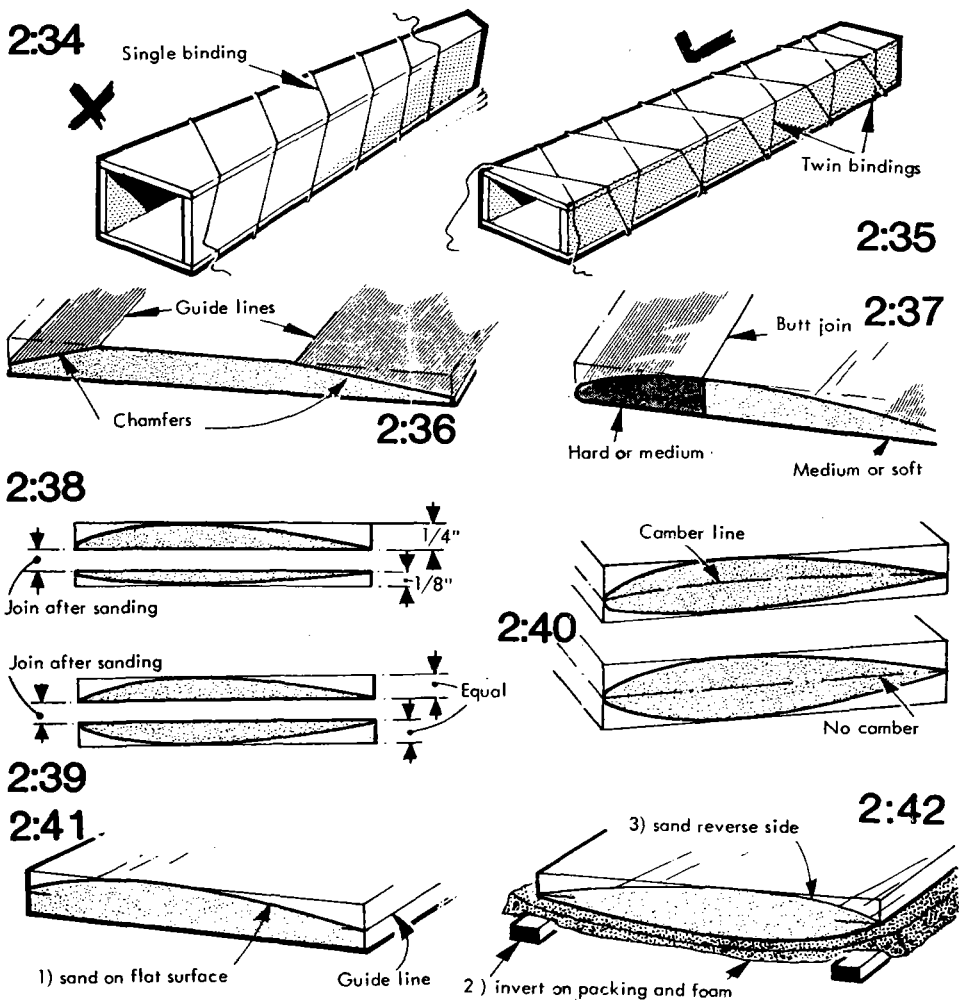

## Curved sheet

Lightweight wings can be cambered by curling the sheet over temporary 'forme' ribs, as seen in 2:43. This is a far cry from the chunky control line wing just described. The cambered sheet will need spacing ribs to enable it to seat in the fuselage without losing its camber. These ribs are glued to the wing and dihedral is incorporated by sanding the centre ends, before joining with tape over the glue. Sketch 2:44 shows this in section.

One form of sheet construction is known as the 'Jedelski' wing, which is not the name of the aerofoil section, but the method of construction itself. A thick, hard, shaped leading edge is propped up on wedge shaped ribs, as seen in 2:45, butt joined by its rear edge to a curved thin sheet. The ribs hold it in shape and remain exposed. It helps if the joint line is marked in the ribs as shown.

Avoid highly arched sections when choosing this method. This means that less rigidity is available, and wire bracing may be needed on towline gliders. Sketch 2:46 suggests reinforcement at the attachment point of the bracing. The section in 2:47 is taken spanwise.

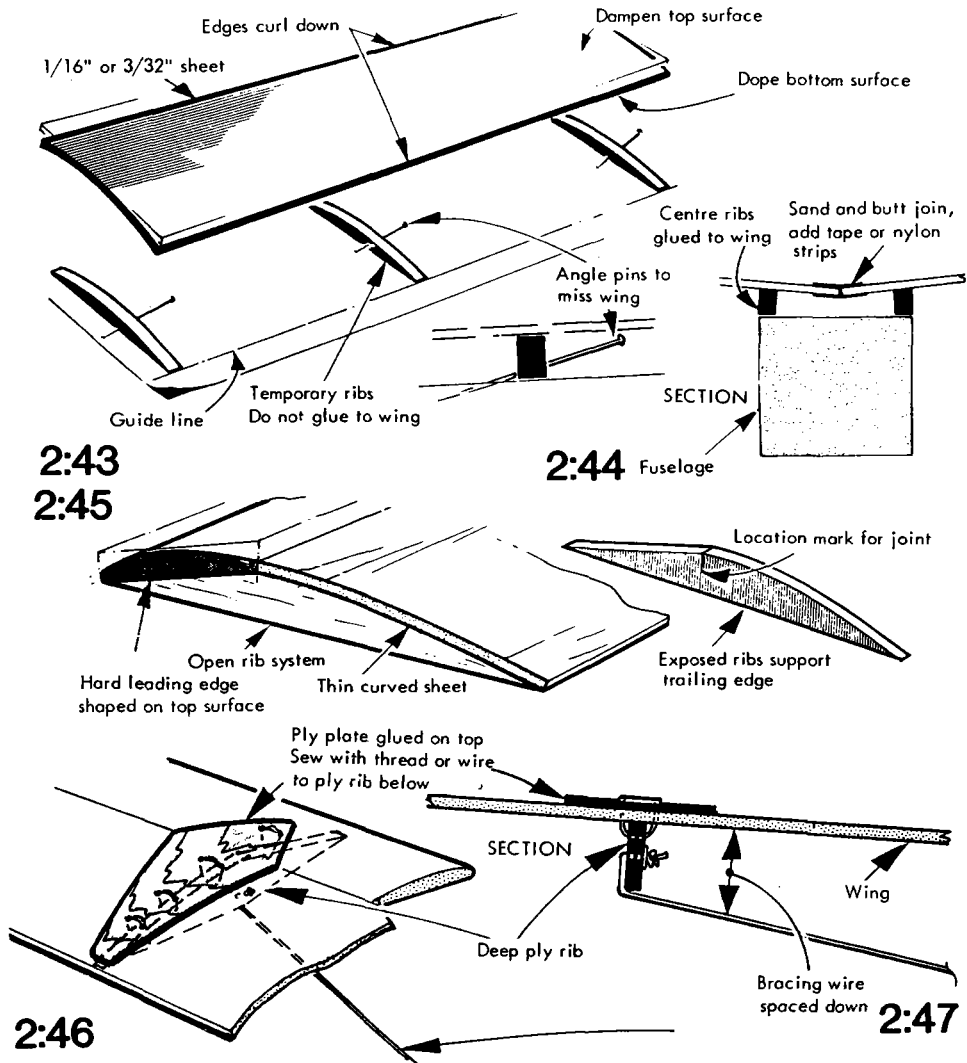

## Double skin wings

By adding a second skin to the wing, with space and ribs between (2:48 and 49) a marked improvement results. Webs between the ribs locate and strengthen both ribs and skins as in 2:50, so that for a little extra effort, strong, warp resistant wings result. They can be flat bottomed, which are easy to assemble on the lower sheet, symmetrical, or near symmetrical (for control line or radio control). Packing is needed under the lower skin as seen in 2:51, this skin being pinned down, so that it partly conforms to the shape before being held accurately by the ribs. So now we come to the ribs themselves for the first time.

Whether the wing is to rely on the skins alone for strength, or to have spars, is not important at the cutting-out stage. A ply or metal template should ensure that a parallel chord wing has identical ribs. Cut in the direction of the arrows shown in 2:52. This ensures that the blade does not dig into the rib or template.

Flat bottom ribs can share a common bottom edge line, or the edge of a sheet, as shown in 2:53. This is economic in wood and ensures that the grain direction is right.

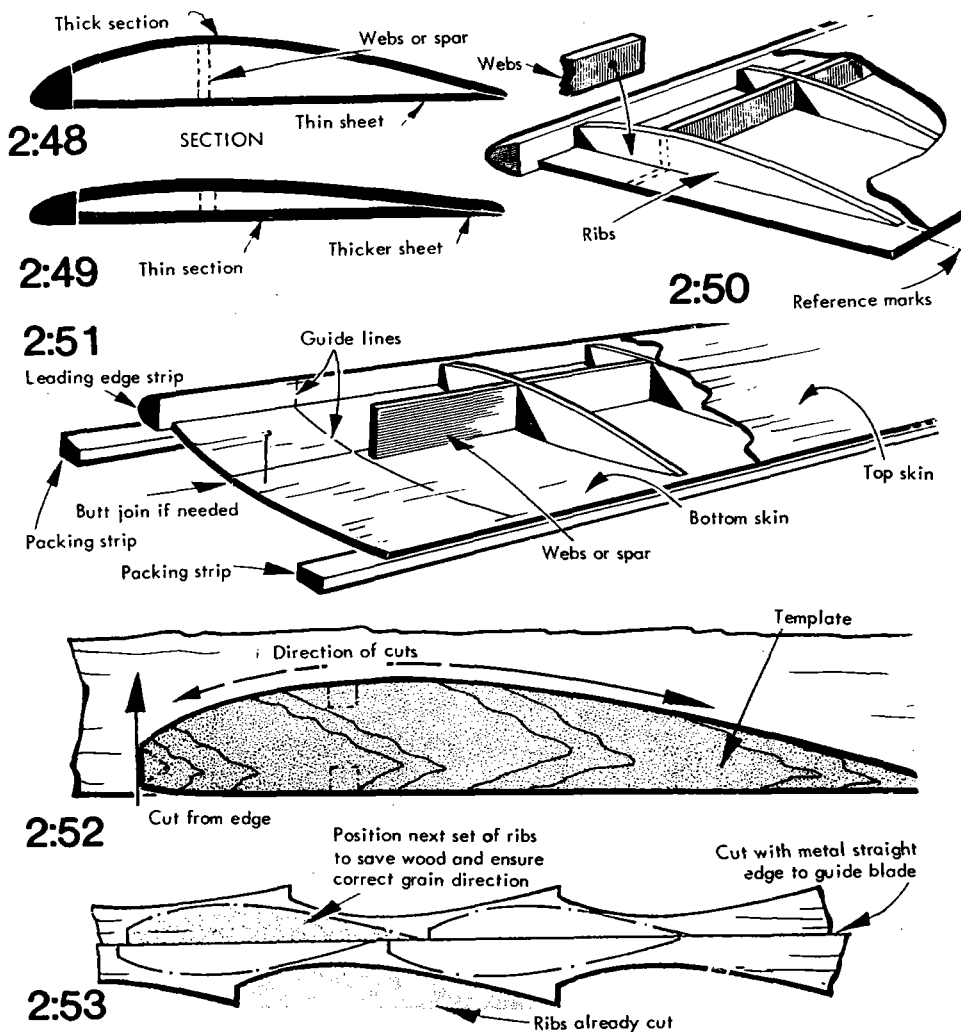



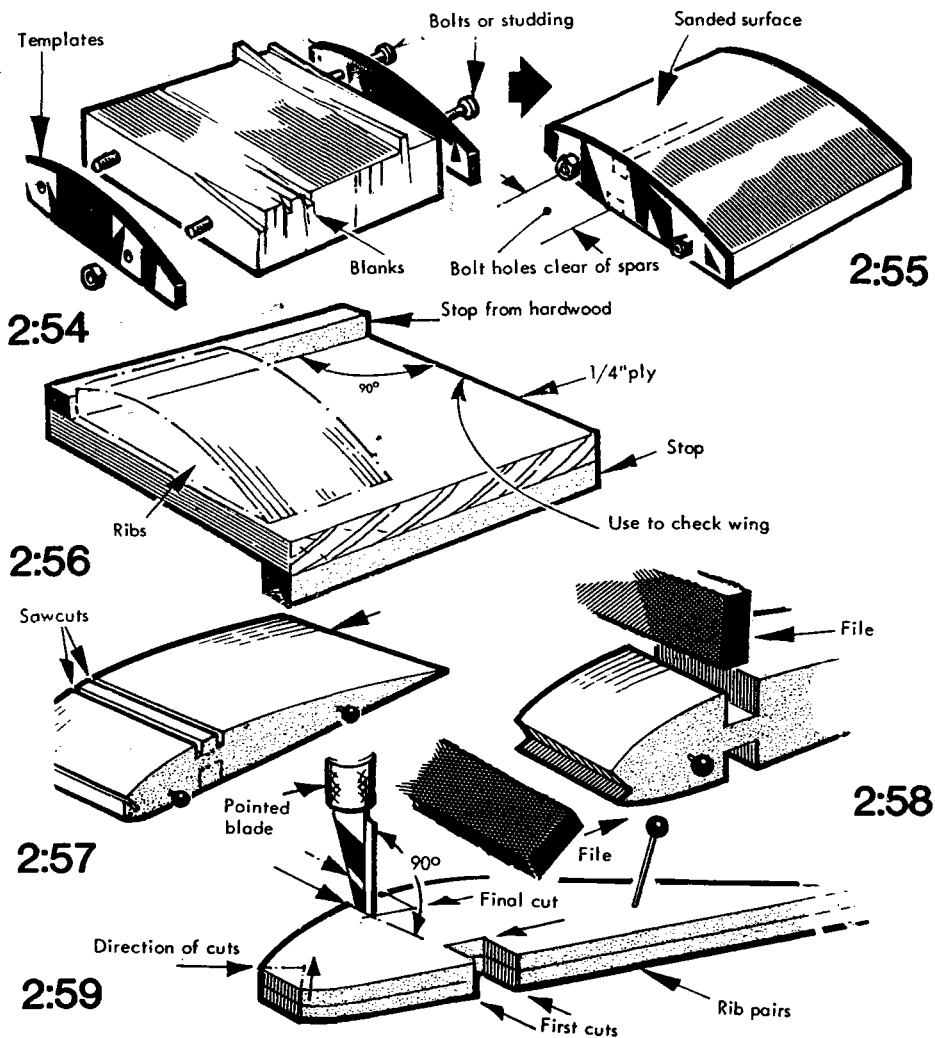

Alternatively, the ribs may be cut by the 'sandwich method'. Two templates clamp a set of rectangular balsa 'blanks', using lengths of screwed rod (studding) and nuts. If there are not many ribs, use bolts or even pin them together and clamp them in a vice, see sketch 2:54. The whole block of blanks is then glasspapered down to the level of the templates, using a sanding block. Spar positions are marked, if required, and the finished block will appear as in 2:55. Ribs can be checked for length by shuffling them and placing together again on a squared-off piece of ply as in 2:56. Notches may then be cut by pinning the ribs together accurately and making cuts with a razor saw or junior hacksaw as in 2:57, finishing off with a flat file of the correct thickness (or thinner), as in 2:58. Note the angled notch at the leading edge in this example, for a square strip of wood set on edge for that purpose (more about this in later chapters).

For knife-cut notches on ribs which are additionally notched, or when there are only a few, adopt the cutting directions in sketch 2:59, otherwise the corners of the notches may break off. Use a pointed knife blade for the job.

A good type of construction for sheet skinned wings terminates at the leading edge with a false 'leading edge' strip, in the sequence shown in 2:60. It is particularly effective where the leading edge is blunt and deep.

Trailing edges can be made by chamfering one sheet to accept the second. The ribs taper right down to the front of this chamfer, as seen in 2:61. A stronger edge results when a wedge sectioned strip is placed inside, as in 2:62, when the ribs should be chopped to fit the strip. A sharp trailing edge results when the second sheet overlaps the lower one (work right on the edge of the building board). Then the overlap is sanded from the other side.

Where sheet is too narrow to go from leading to trailing edge in one piece, it should be butt joined on a flat surface before it is fitted. The technique shown in 2:63 makes this easy. Be sure the glue is dry before peeling off the tape.

### Washout

Taking the 'Jedelski' wing first; beneficial washout can be introduced by trimming the trailing edge back at the tips to produce a slight taper

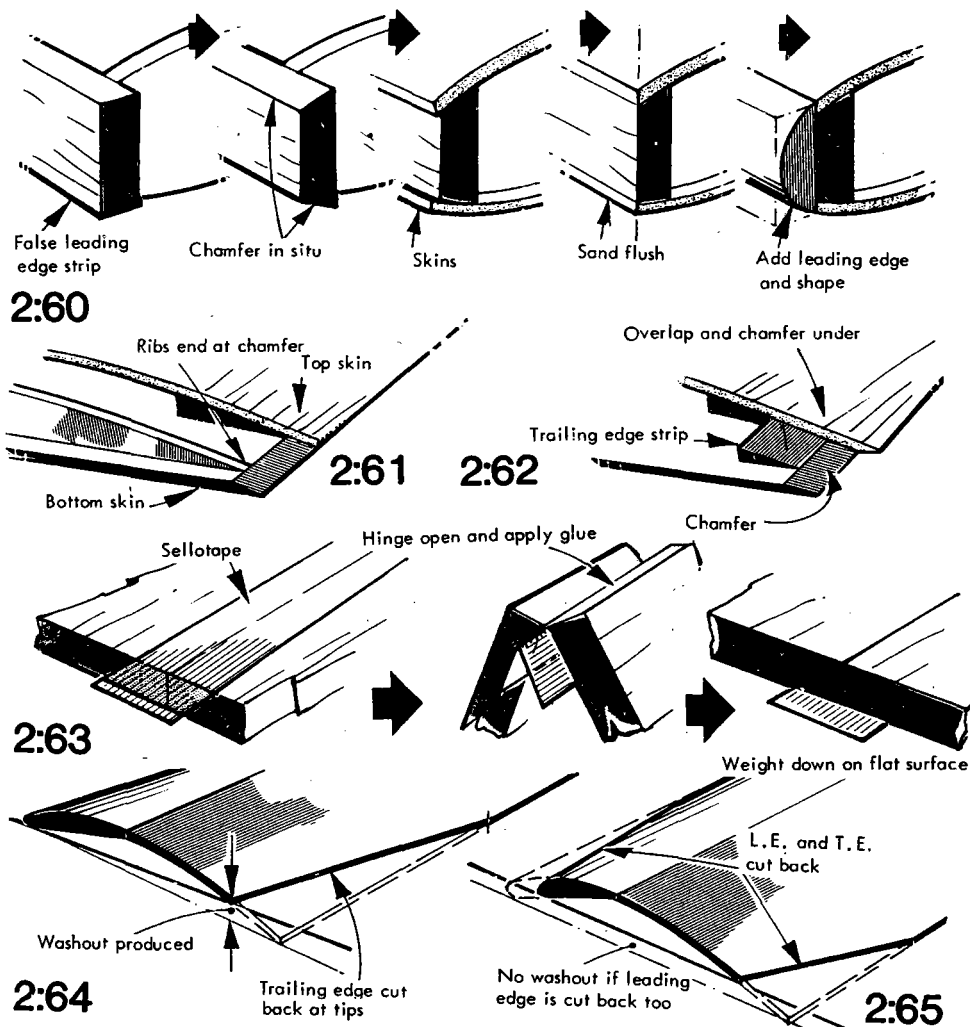

as seen in 2:64. Do not trim the leading edge too, as in 2:65, which nullifies the washout effect.

Solid wings must have washout incorporated (should this be needed) at the first stage of sanding to section. Mark the washout line required on the sheet edge as in 2:66, and sand the bottom corner up to this line before shaping the top to a curve. Single skin (curved sheet) wings may be cut back as was done with the Jedelski type, or warped during the shaping process as in 2:67, by use of a specially shaped end rib or temporary rib.

**Tips for tips**

In the same order, a wingtip may be strengthened and made more attractive in appearance by adding soft balsa blocks, or sheet with grain running from L.E. to T.E., or by fitting a ply plate to maintain the camber, all as in 2:68. Solid flat bottomed or symmetrical section wings are easier to deal with, because the tip pieces do not have to be hollowed below, as was done in the previous example. 2:69 shows that the shaping is done after gluing in place. The double skin wing, being lighter, deserves a spot of laminating at the tips, using two soft blocks with the inner one hollowed out as in 2:70, which is fairly blunt, or in 2:71, where it is more rounded.

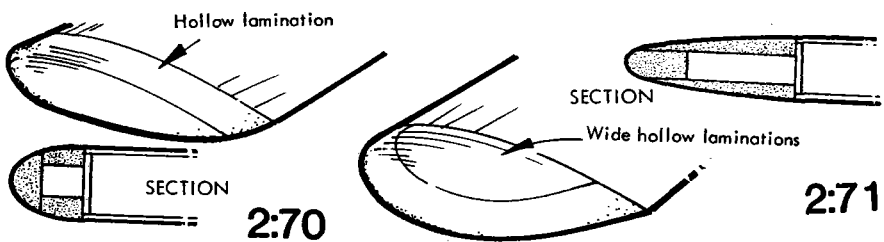
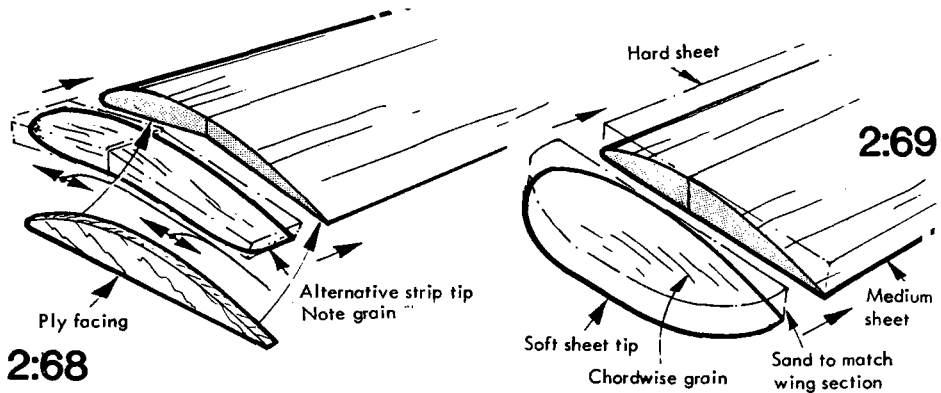
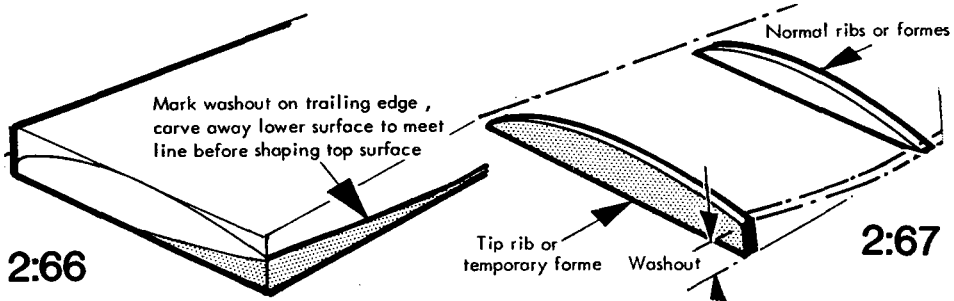

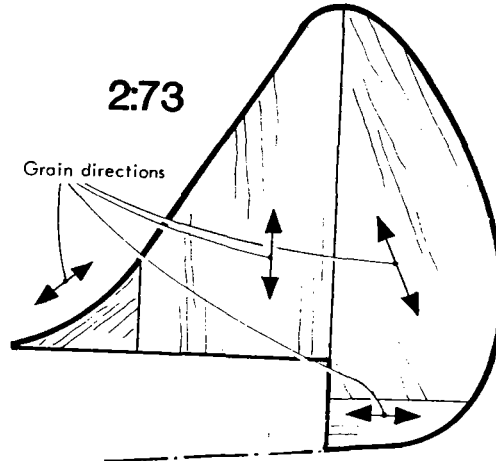
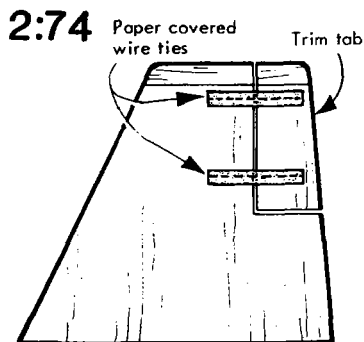
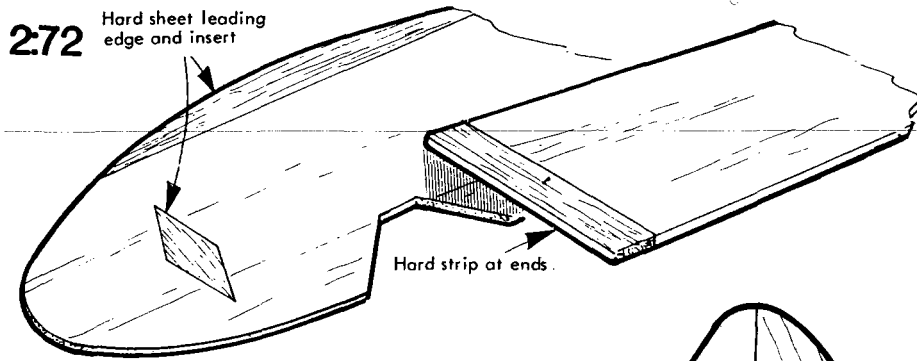

## Tails

Tailplanes and fins may be made from solid sheet shaped to the profile of the component. If the shape is more complex than a simple rectangle, triangle or oval, it pays to butt join reinforcing pieces in place, or inset reinforcement with appropriate grain direction – see sketch 2:72. The fin can be treated in a similar manner to tailplanes or made up from several pieces of sheet, cut so that the grain direction follows nearly parallel to the principal edge, as seen in 2:73.

On free flight models, a rudder or trim tab will most probably be needed to obtain the desired flight pattern. For small models, plant ties of the wire-in-paper type are useful here, but remember that once set, the tab is best glued, to avoid accidental change of angle. Hinges proper will be dealt with later on, where they have a chapter to themselves.

# CHAPTER 3

## Profile fuselages

**Glider**  
**Fun rubber power**  
**Control-line**  
**Free-flight**  
**Radio Control**

**See also Chapters  
2, 4 and 5**

Profile fuselages may be simple sheet cut-outs, laminated, or built-up structures. The elementary chuck glider and rubber powered junior model are simply cut from sheet balsa to the desired profile, but left like that, they may quickly deteriorate. Take the simple sheet glider fuselage for example; that in sketch 3:1 has a simple slit for the wing, but the ends of that housing will soon break as the wing is slewed on landing. Far better to have a strip of balsa each side to seat the wing, which may then be firmly glued in place (if it is a small model) or retained with rubber bands over short dowels. The top part of the

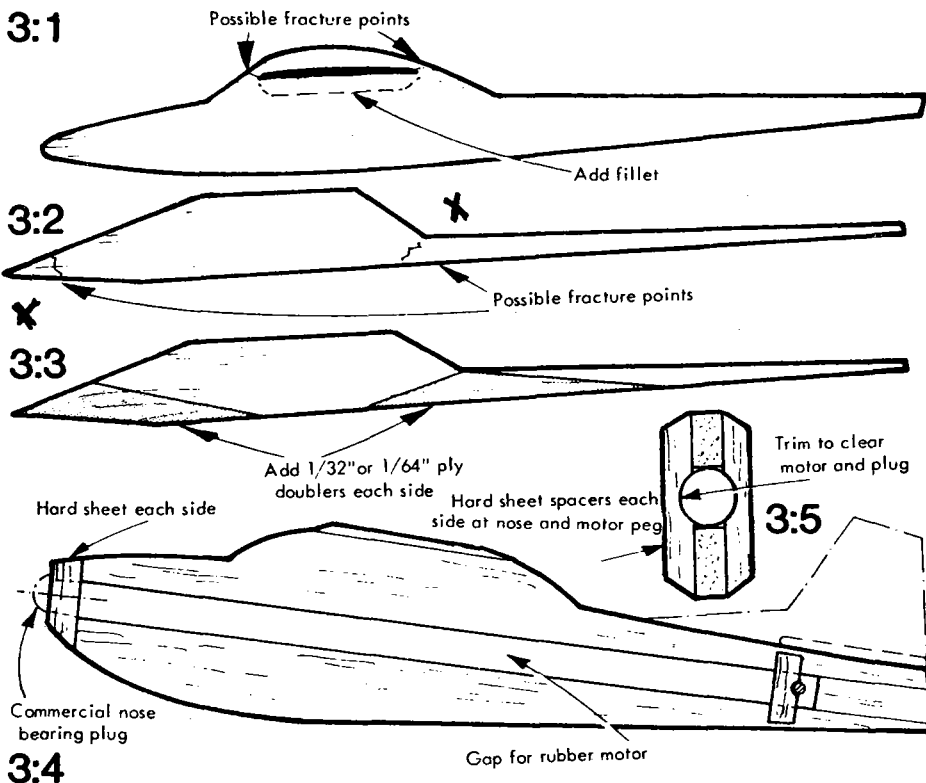

fuselage can then be cut off and fixed to the wing. The rakish fuselage in 3:2 is too sharp for practicability and has another weak point aft of the wing. If you must have shapes like this, add thin ply each side to reinforce the weak areas as in 3:3. Note how they taper off gradually: if they ended suddenly, the weak point would be moved further along. A simple junior rubber powered model is shown in 3:4, with the cross sections in 3:5.  $\frac{1}{8}$ in. sheet is about right for this fuselage of say 8in. length.

In a control line model, that simple sheet, even  $\frac{1}{2}$ in. thick, will not support the engine. The type of laminated fuselage is safer, as in 3:6. The main load of engine and wing can be supported by  $\frac{1}{4}$ in. ply (for say, a 1 to 2.5cc engine model). The rest of the fuselage depth is made up by  $\frac{1}{4}$ in. balsa sheet. Larger engines will need proper hardwood bearers (see chapter 5), in this case beech, and they are tapered to blend into a balsa fuselage of the same thickness (say  $\frac{3}{8}$ in.). The balsa can be medium soft, because the bearers are covered with  $\frac{1}{32}$ in. ply both sides to act as doublers right back to the wing. See 3:7.

Larger, sleeker models with bigger engines will demand extra reinforcement in the form of full length hardwood (spruce) strips laminated with the balsa, for example  $\frac{1}{2}$ in. square beech bearers,  $\frac{1}{2}$ in. x  $\frac{1}{8}$ in. spruce and  $\frac{1}{2}$ in. sheet balsa.  $\frac{1}{32}$ in. ply doublers are also used as before, all as seen in 3:8.

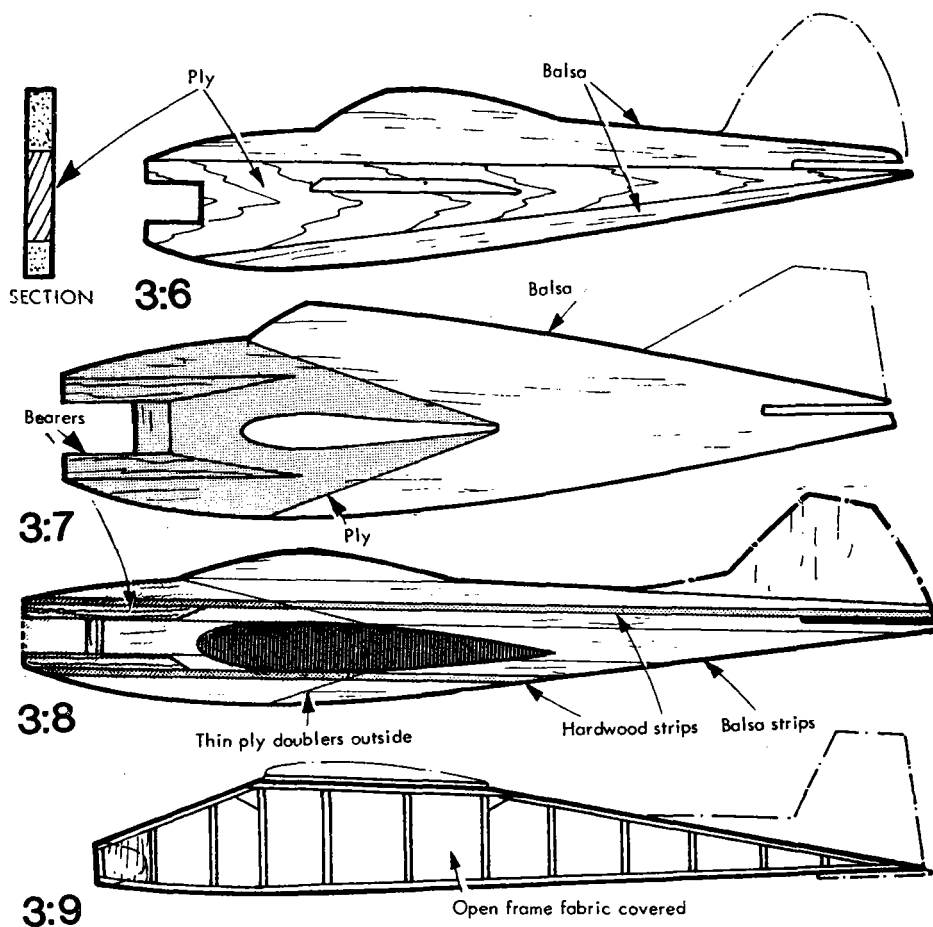

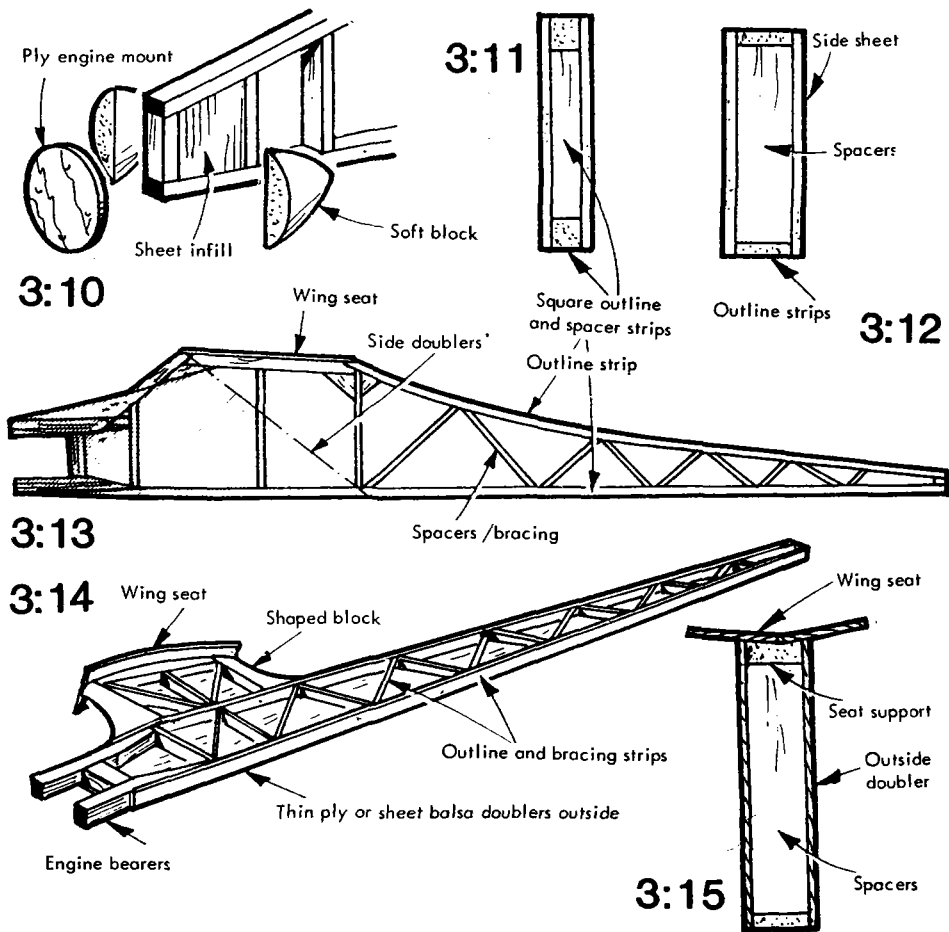

For free flight power, the smaller model can have a simple ladder-like frame which serves as a fuselage when tissue covered. This 'fabric' provides rigidity and a piece of thick sheet fills the nose bay for a motor mount to be added., see 3:9.  $\frac{3}{16}$ in. square strip should be strong enough for small models (up to 0.5cc) 24in. long, provided the strip for the outline is hard, otherwise  $\frac{1}{4}$ in. square might do.

The nose detail for this type of small model appears in 3:10. The front fuselage bay is filled in with sheet of the same thickness, and a plywood plate, to which the motor will be bolted, supported with shaped balsa blocks, grain fore and aft to give support against twisting.

The fuselage frame itself can be made from square section strip, with or without sheet balsa skinning. However, some weight can be saved by using rectangular strip as in 3:12. With a wider fuselage profile, this will be more rigid, but sheet skins are needed to prevent the outline buckling.

A combined example of profile construction is used in the power model fuselage of 3:13. Intended for larger engines, beech bearers are bonded in with thin ply or sheet balsa skins partway back, then Warren type bracing (diagonal spacers) helps to keep the outline in shape, relying less on the covering itself. The wing seat is reinforced and provision is made for rubber band fixing onto dowels.

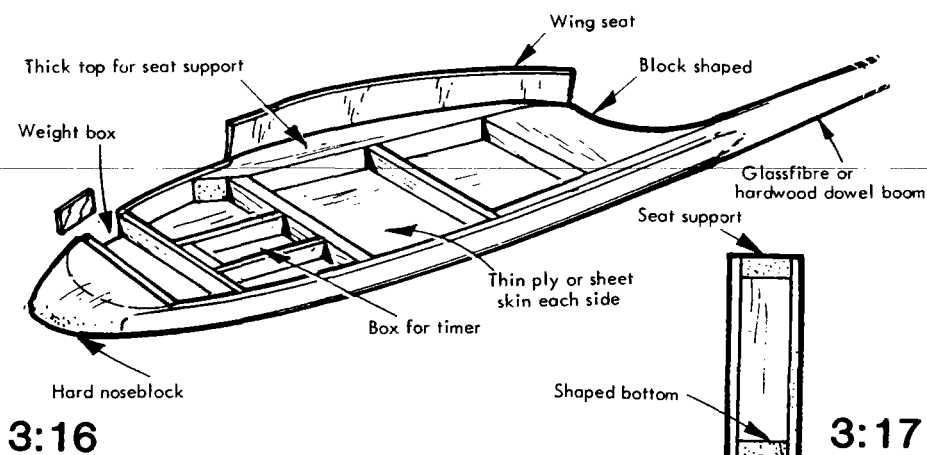

3:16

3:17

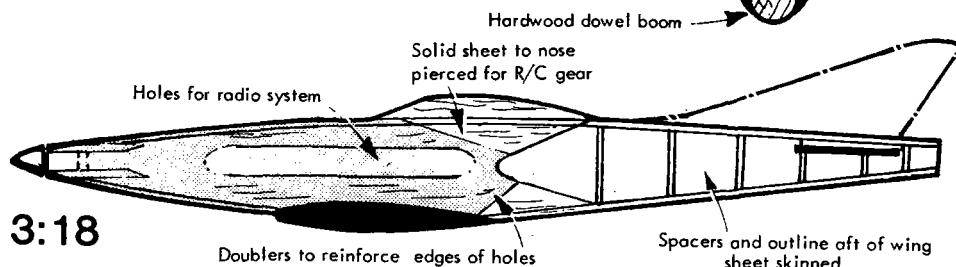

3:18

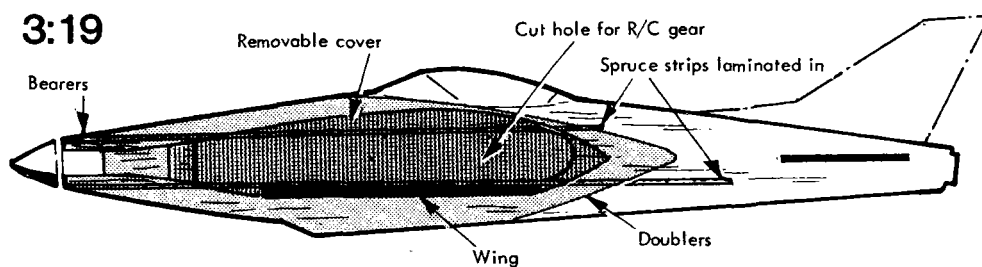

3:19

Sketch 3:14 shows a pylon model with fully sheeted sides . . . one side has been removed to show the structure, which on smaller models can be simple vertical strip. That wing seat detail appears in 3:15.

A small glider is seen in 3:16. This has a 'pod-and-boom' layout, the boom being solid hardwood dowel or glassfibre tube, which is blended into a profile fuselage 'pod', sheet or ply covered. As the strength lies mainly in this skin, the spacers and outline aid rigidity. There is a gap for adding ballast to balance the model and a box to accept a flight timer. The thickness of this item often dictates the thickness of the pod, for it is recommended that only one side is cut out. The boom is located by thicker strip shaped at the bottom and overlapping side panels, as shown in 3:17.

### Radio control

It might be thought that radio systems could not be fitted into profile fuselages. Well, true, some modellers manage to pack it all into the wing, but this may lead to linkage difficulties. If the model is large, miniature radio may be dropped into a slot in an otherwise solid front fuselage, per 3:18.



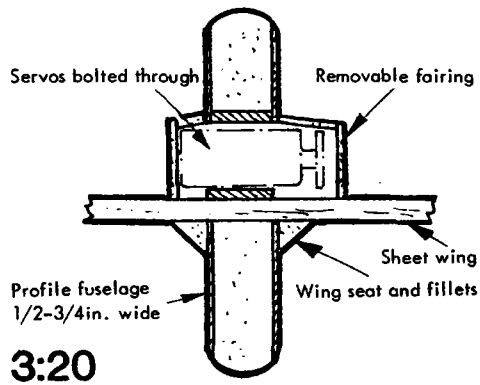

3:20

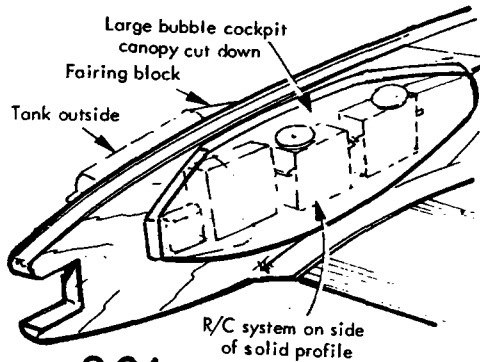

3:21

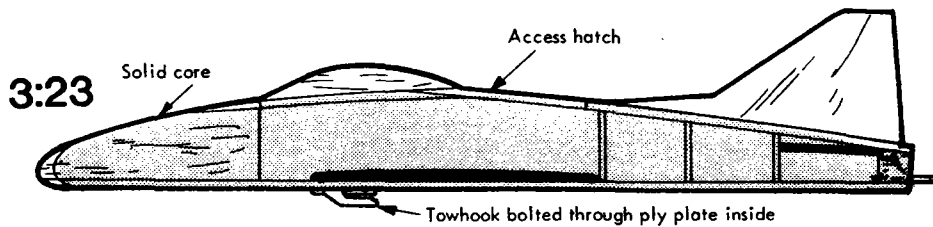
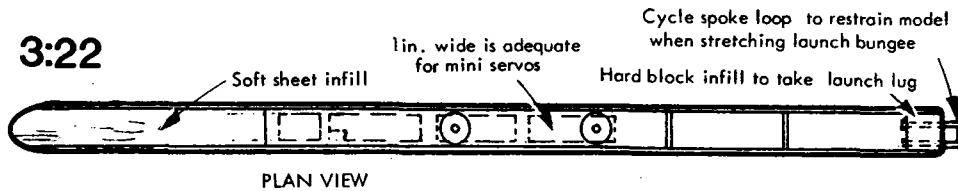

3:23

With a larger cut-out, the edges of the hole need hardwood strips, let into a solid sheet profile (remember 3:8). Here this model is smaller and uses a solid wing. The R/C gear needs a light cover as indicated in 3:19.

A typical section of this fuselage is seen in 3:20. Only the servo arm side of the covers need be removable. Larger models with small servos can have a solid or built-up profile fuselage without openings, or at most, one for a deep receiver; the system hides in a plastic bubble on one side of the fuselage . . . a large bubble canopy might fit, or parts of one adapted with thin ply between. The fuel tank, clamped on the other side, can also be faired with soft block (3:21).

Miniature servos are so thin that they can sometimes be accommodated in line between the side skins of a profile fuselage; for example, the catapult launched model seen in plan view at 3:22. An important feature of these catapult models is the restraining lug at the tail end. It has to be made from strong wire (cycle spoke) and held with nuts through a solid block. All the pull of the bungee is exerted here before release. The side view in 3:23 shows the extent of the side skins. That towhook needs to be firmly fixed too. Screw it to ply inside.

Catapult R/C models are fast and need to be built accurately; they also need to be flown by pilots who have gained experience on more docile machines.

# CHAPTER 4

## Open frame models

**Fuselages, wings and tails for rubber, sport power and glider**

**See also Chapters 9, 10 and 11**

Lightness is the key and reason for making airframes in an 'open frame' form. A bonus is the wood saved and a slight penalty is the extra time it takes to build such a model.

Traditional rubber powered duration models usually employ simple box framework for the fuselage. The basic shape need not necessarily be given sweeping lines, but formed as a series of straight lines, which are represented by four strips going lengthwise, known as 'longerons'. Vertical strips called 'spacers' keep them apart and produce ladder-like side frames as shown in 4:1. The angles of the top form a suitable seat for the wing on top and a tail below, aft.

A stronger method, requiring more patience, is seen in 4:2, where the longerons form smooth curves.

In order to maintain the shape without complex bracing, the spacers become what is known as 'Warren bracing' as in 4:3. The frames do not now rely so much on the tissue covering for rigidity. For the sake of

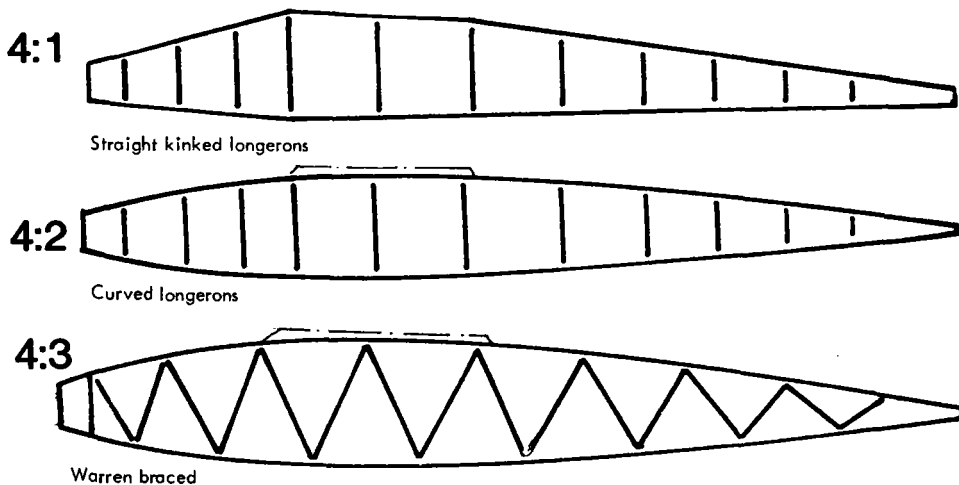

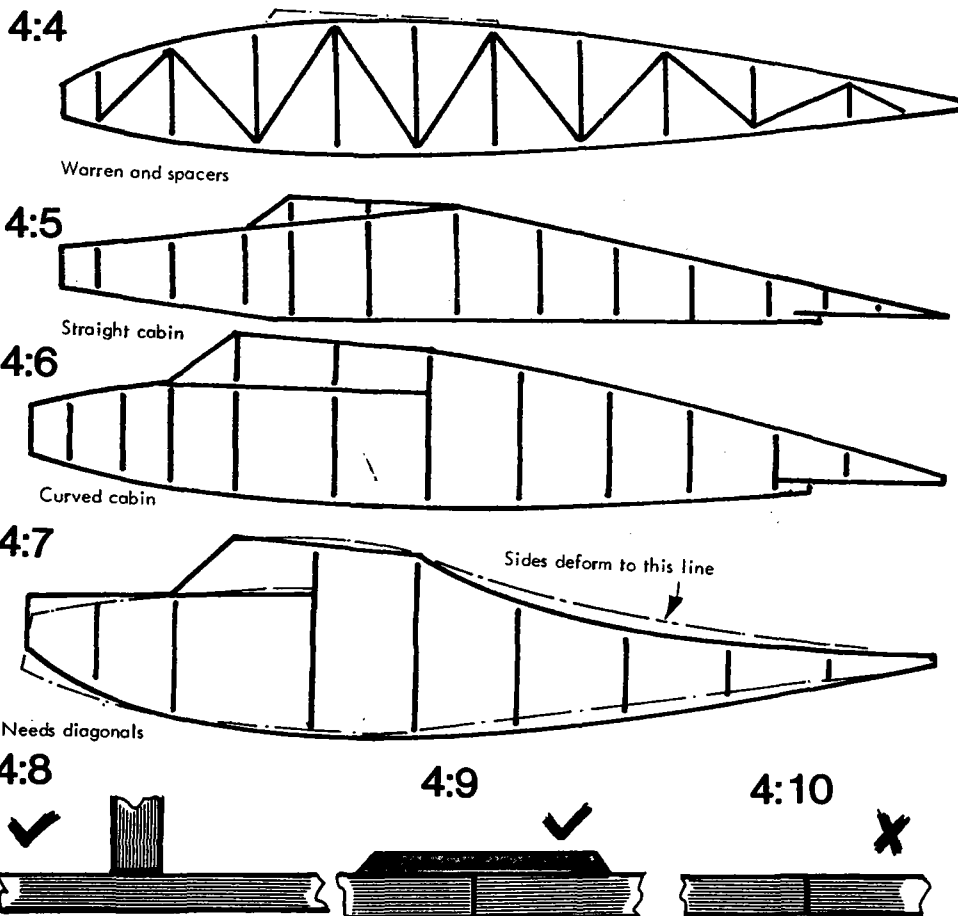

clarity all these sketches show a gap between longerons and spacers or bracing. In reality the joints need to be made carefully, as will be explained later.

The spacers and bracing can be combined as in 4:4. Wing seat strips may be added as shown dotted.

Sport models may be given a cabin by re-arranging the longerons and spacers and the tailplane can have a recessed seat. In its simplest form, it could look like 4:5, which returns to the straight line form, or as 4:6, where curves are introduced.

Go easy on those curves when the frame is not braced. The chances are that the sharply curved longerons may force each other to adopt a mean line as seen in 4:7. In this example it will be noted that the top longeron is concave and not balanced by the convex lower one. The sharply curved lower nose longeron pulls the flatter top nose longeron down, distorting the nose spacers. Diagonal bracing would avoid this.

## Joints

Spacer-to-longeron joints need to be cut to match, both at the correct angle and without gap or being over-tight (4:8). If force is used the next spacer will drop out. Avoid longeron joints unless needed as in 4:1, 5, 6 or 7. A 'superglue' joint helps, so does a sliver of  $\frac{1}{32}$ nd ply as 4:9, not a plain butt and glue as 4:10.

Where bracing meets uprights, the ideal shape for the diagonal bracing ends is seen at 4:11. It takes patience to get it just right, but is well worth it. 4:12 shows that Warren bracing can be simply chamfered, because there is plenty of longeron in contact with the ends.

With all those short strips to cut, try a little cutting jig like that in 4:13. A fuselage with a rectangular cross section needs pairs of spacers, so that a second identical side frame may be made. If the fuselage is square in section, then four spacers are needed at each station. Imagine how many identical spacers are needed for parallel sided parts of the fuselage.

### Tail seats

The angles of the longerons do not always position the tailplane at the correct angle, so a suitable step may be created by re-arranging the longerons and adding filler pieces and gussets as sketched at 4:14, making provision if needed, for a hardwood dowel to take rubber bands to retain the tailplane.

If the tailplane is below and has a cambered top surface, shaped sheet seats are needed to continue the longerons aft as shown in 4:15.

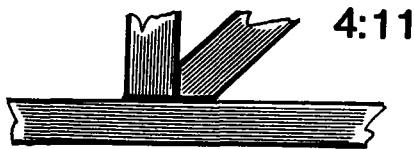

4:11

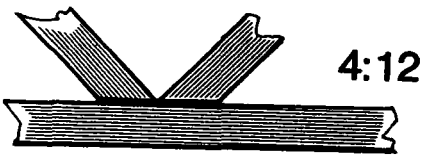

4:12

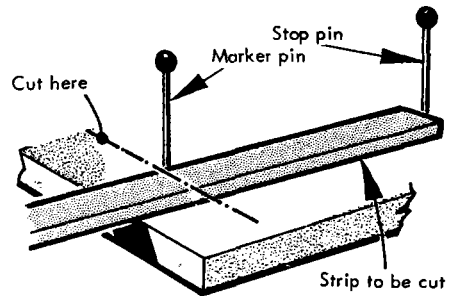

4:13

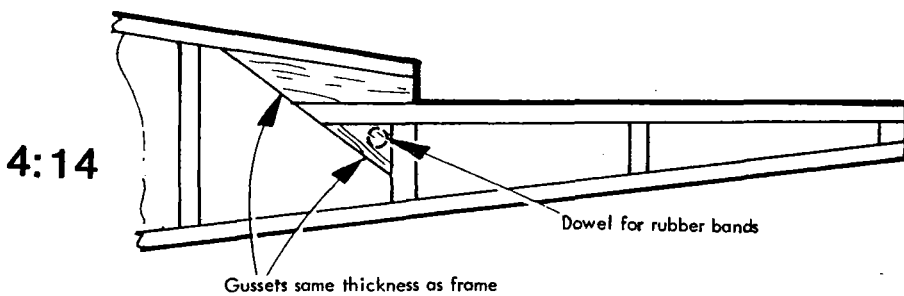

4:14

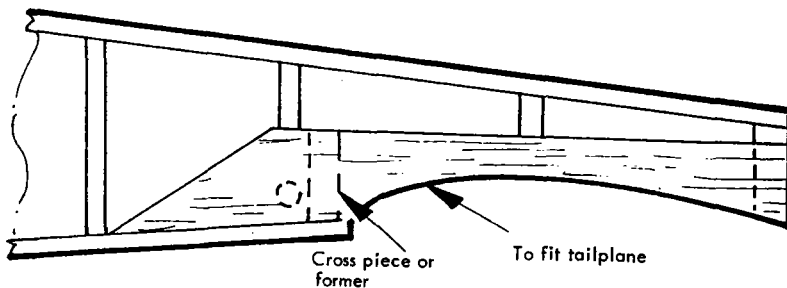

4:15

Wing seats on low wing models need a similar treatment; those sheet seat pieces should be of the same thickness as the longerons as shown in 4:16. The deeper the camber of the wing, the deeper the seat needs to be, so that it does not have a weak point at the mid camber. Deep cross spacers also help to reinforce the fuselage fore and aft of the wing.

Continuing the theme of local reinforcement, we have a typical nose treatment in 4:17, where the nose of a typical rubber powered model receives reinforcement and a strong ply former, little more than a frame itself, to keep the nose square or rectangular as required and provide a hard wearing surface for the nose block. Further back, the pull of the rubber motor on its retaining peg needs gussets and an area of sheet to hold it, as seen at 4:18. The fuselage gets a lot of handling here, as the helper grasps the model whilst it is wound. Models intended for higher performance often have a lighter but hardly less strong detail here as in sketch 4:19.

Just how far can one go in keeping the airframe light and rigid (so that there is a better performance) can be seen in 4:20 : a high performance rubber powered model's fuselage. In order to give rigidity the longerons are angled at 45° to resist crushing and the spacers have

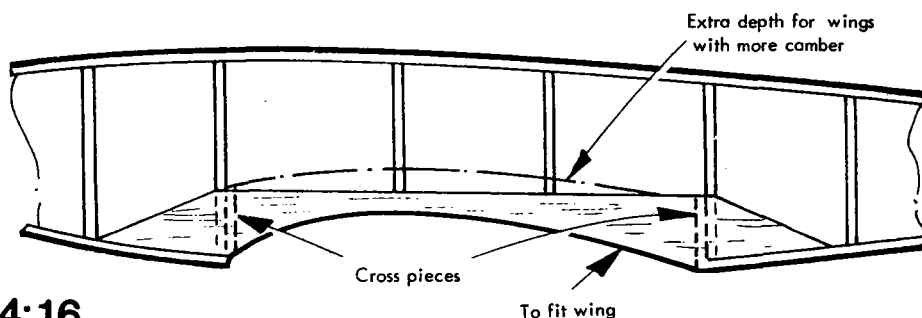

4:16

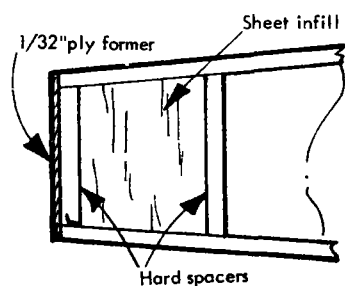

4:17

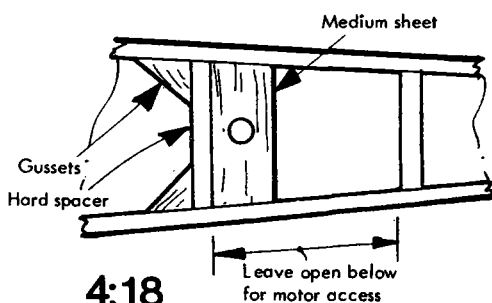

4:18

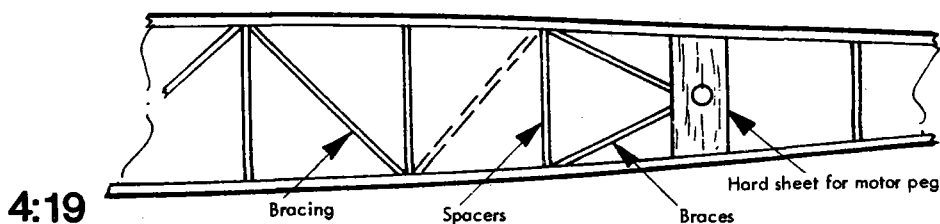

4:19

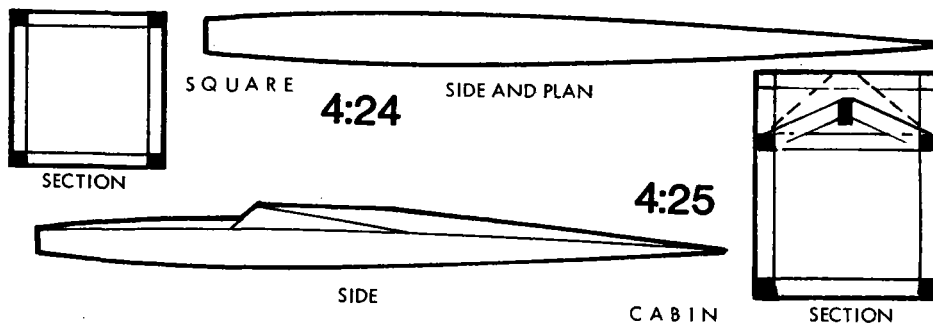
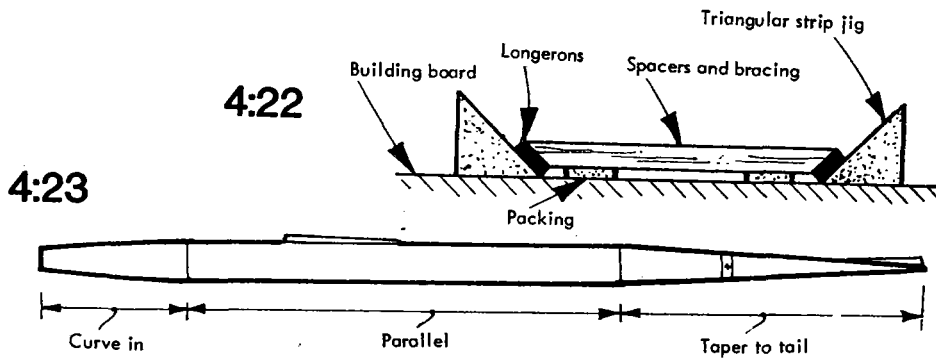
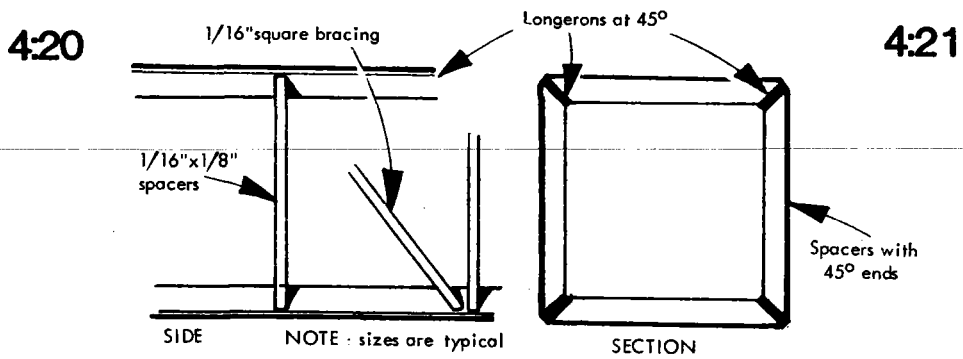

to be cut to this angle to maintain the longerons accurately, see the section in 4:21.

Special tricks are often used to make the side frames. Look at sketch 4:22; triangular jiggling strips hold the longerons and packing under the spacers ensure that they do not protrude past the edge of the longerons.

Such fuselages are often slim and near parallel, so that the longerons are not forced to bend across their less flexible axis. 4:23 shows the general side view of such a fuselage.

There are many combinations and permutations on the basic square longeron fuselage as applied to rubber powered models (even lightweight gliders have adopted some versions). Take the following sections and outlines for example – square as in 4:24 and rectangular to form a simple cabin as in 4:25.

Turn the square on edge for a regular diamond, as 4:26. The wing needs to be braced if it is to perch on the top edge, but a streamlined fairing can be built onto the basic diamond section, by adding sheet at

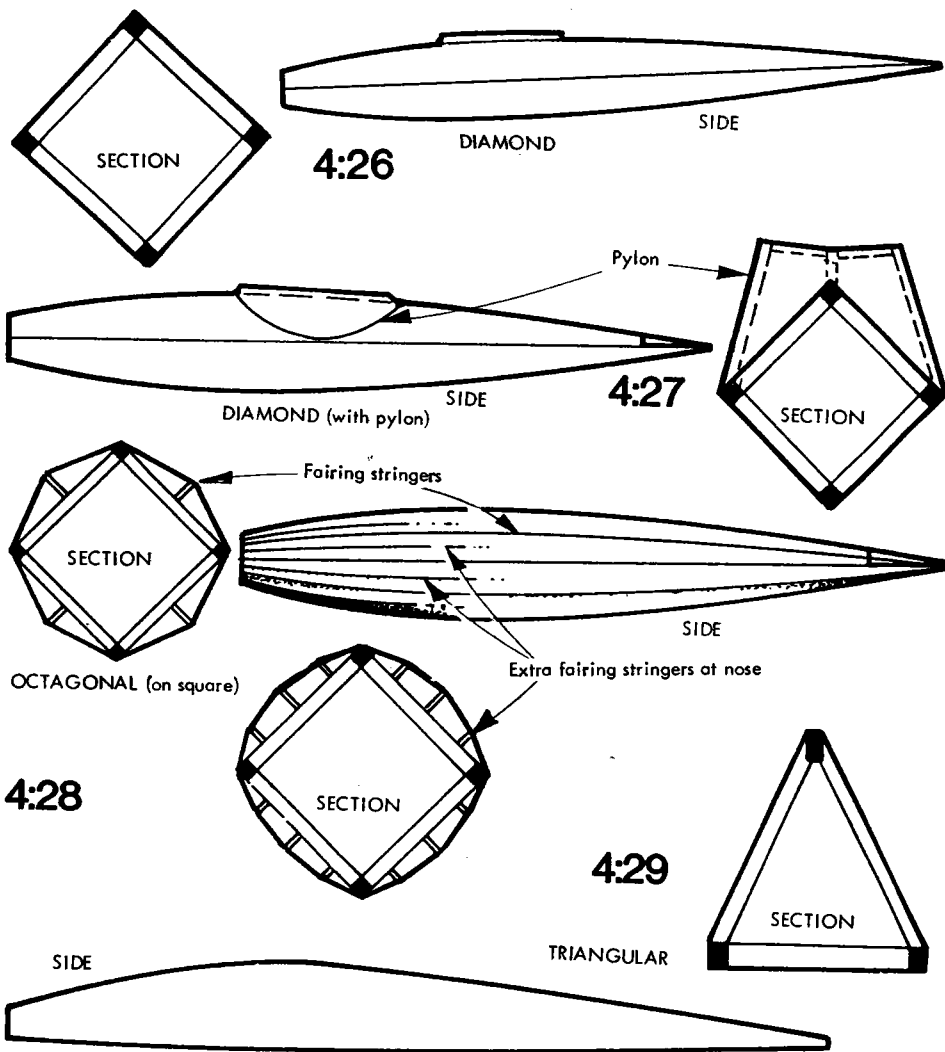

the top to meet the wing and spacers below to meet the corner longerons as seen in 4:27.

Quite elaborate versions can be created by placing thin strips down the centre of the spacers to make an octagonal main section as seen in 4:28. In this case extra short fairing 'stringers' (strips that give shape without contributing in a major way to the strength) are added at the nose to fair it into a noseblock or spinner.

At the other extreme; 4:29 shows a triangular fuselage, economic in weight and in timber, but rather restrictive inside when it comes to packing in lots of rubber for powering the beast. The triangle can have its apex uppermost or below, depending on how it is intended to fix the wing and tail.

All these examples can employ spacer and bracing methods already described and apart from the triangular job, start life as two side frames assembled flat on the building board over the plan, held there by pins around the outside (not through) the longerons. Completed sides are then joined by cross pieces while being held between suitable blocks of wood or small boxes to make a simple jig. – More about this later . . .

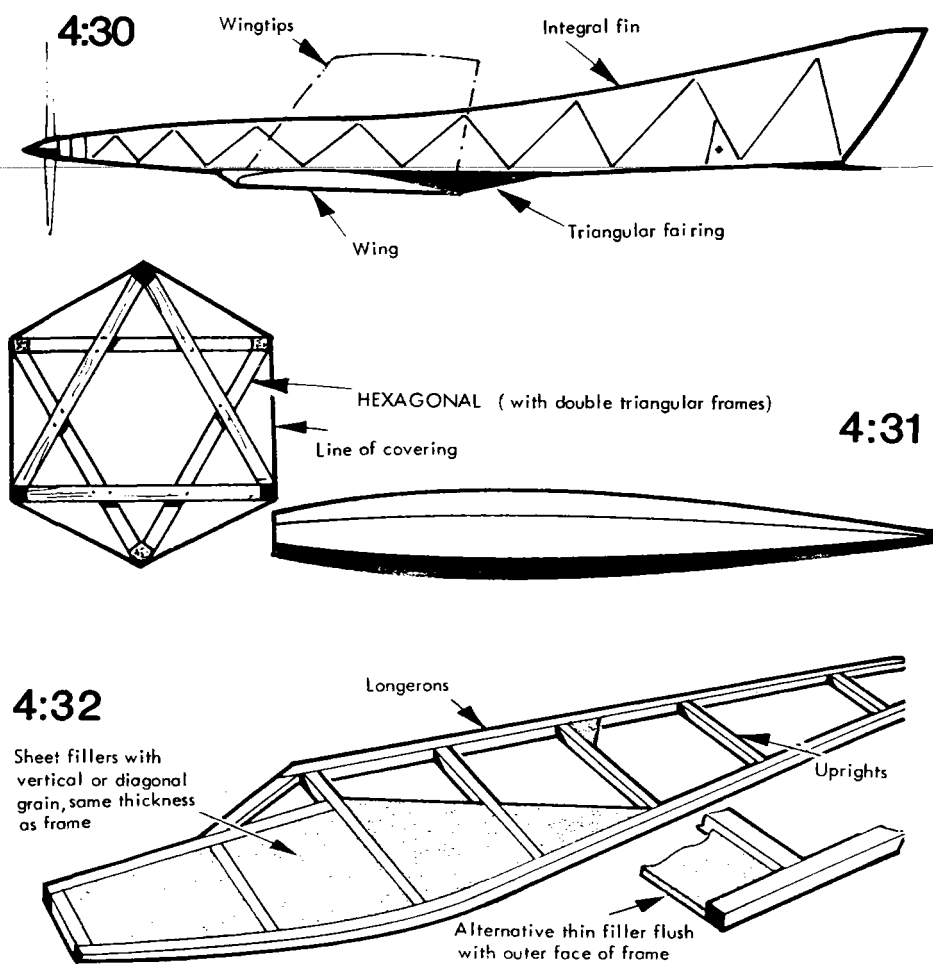

Carrying the triangular frame to extremes, 4:30 suggests a 'fun' type rubber powered low wing model, where the fuselage becomes a fin. No doubt owners of small internal combustion engines may adopt it for a lightweight sport machine!

One of the author's experimental rubber powered models used a double triangular combination to bring the cross section to hexagonal, while still leaving space for the motor. The basic triangular fuselage was built, then extra spacers glued to the existing ones to make very rigid formers. A second set of longerons were added. The result was not twice the weight of a simple fuselage, because the wood was of smaller section.

### Power model fuselages

Back to basics again; sheet infill panels may be added to strengthen the basic longeron and spacer frames, where there is much handling, point loads of landing gear and the need to provide rigidity when starting the engine. 4:32 is a general indication of the infill pattern in a simple cabin sport model. You only have to experience the shaking that a fuselage receives when you try to start your first model engine, to realise the importance of this sheet filling.



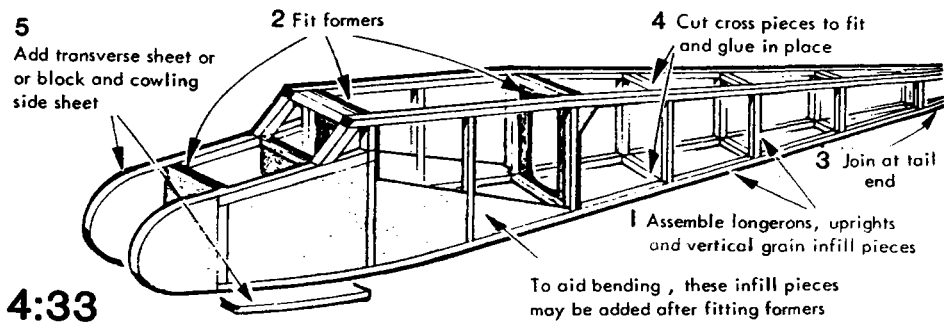

4:33

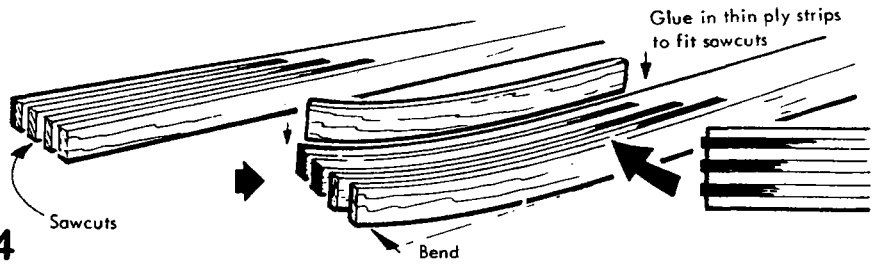

4:34

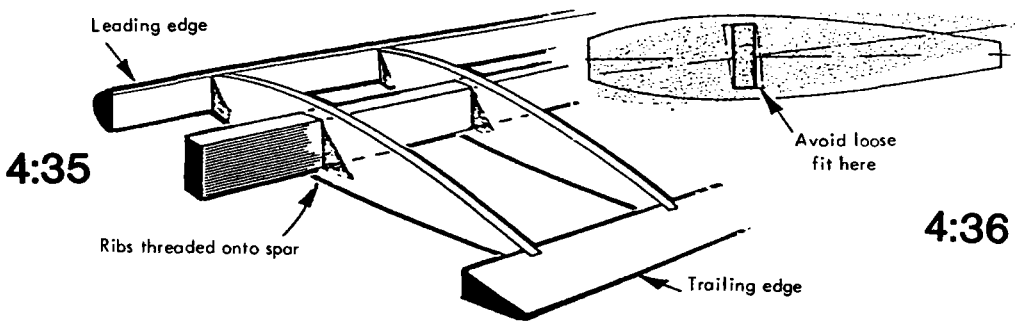

4:35

4:36

Clearly a certain order of assembly is desirable and sketch 4:33 explains the sequence for a typical sport power model fuselage. At this stage no comments are made in respect of engine mounting (these will appear in the next chapter). It is rare for the sequence to be varied, but bear in mind that those parts which form sub assemblies need to be firm and handlable before going further. Formers will keep the sides upright in correct relation to each other, but just to be certain, a small right-angled piece of card can be used to check that the formers themselves are both upright and at 90° to the fuselage centre line on the plan view.

Sometimes the fuselage has to be assembled upside down, for example if it has a flat top and curved underside. It is a good plan to mark centre lines on the formers and spacers, so that a check can be made, not only on the plan, but with a metal straight edge along the top.

Where longerons have to be bent in sharply at the nose, they may need to be preformed to the curve either by steaming or, in the case of large models, slit and laminated with slips of ply as in 4:34.

**Open frame wings**

One of the simplest arrangements appears in 4:35, but needs careful piercing of the ribs. When gluing in the spar, either use cyano adhesive or position the spar slightly to one end, apply glue to each rib where it meets the spar, then slide the spar home to drag the glue into the joints of all ribs.

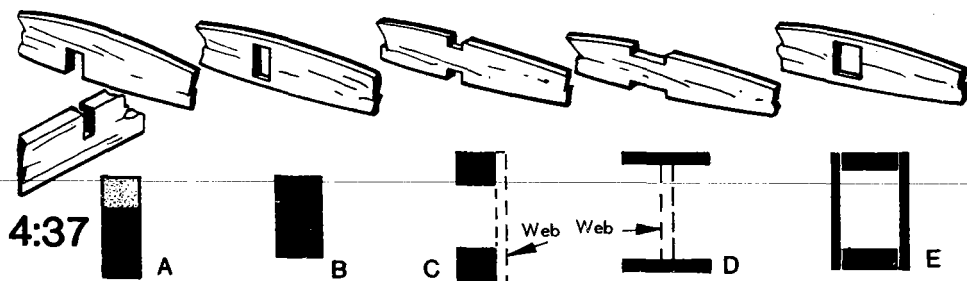

4:37

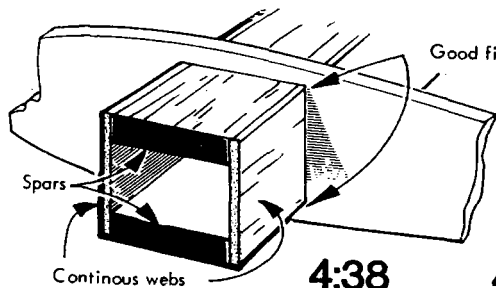

4:38

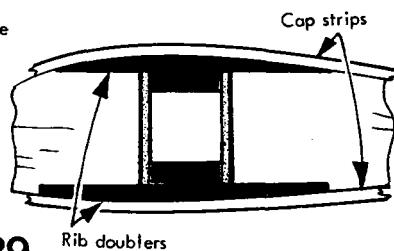

4:39

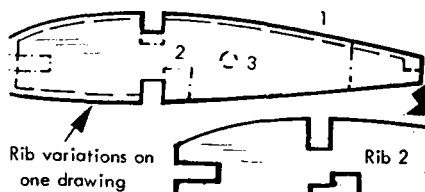

Rib variations on one drawing

4:40

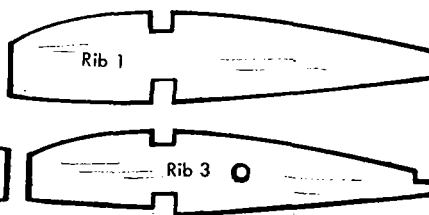

Cut back to reduce chord (also makes rib more compatible with washout)

4:41

Basic rib

Although rib and spar systems have been dealt with in their most elementary form in chapter 2, open structures put a greater emphasis on detail. In sketch 4:37 can be seen some of the main spar arrangements in single spar wings. To half notch the spar into ribs as at 'A' reduces the spar strength, yet rib strength suffers in the central spar at 'B' (described earlier). 'C' is the most often used method, twin spars take care of compression and tension and, often, a linking web aids rigidity. At 'D', all the spar material is at the surface; so it contributes more strength. The webs are essential, for such spars will buckle without them. A box spar is a double webbed version and appears at 'D'. This is one of the strongest types of spar but sometimes needs the ribs to be strengthened, for as seen in 4:38 the spar takes a large chunk out of the rib. Sketch 4:39 shows how stiffeners and cap strips restore the strength.

### Rib shapes

Quite often, a drawing will indicate a variety of rib details on one basic outline as in 4:40. It is easy to chop out the wrong notches when making ribs from such a detail, so trace each version and check it with reference to the wing plan view. Sketch 4:41 shows how a standard rib can be sliced to suit smaller chords at wingtips.

## Leading and trailing edges

Pre-shaped stripwood is available for leading edges. However, not all wings will match up to the section of the strip and transition between the strip and rib needs to be smooth (4:42 explains). The practice of using a square strip on edge is good only so long as the strip is large or small enough to blend in when it is sanded in situ as seen in 4:43. Ideally the corners of the strip should be in line with the camber line of the wing section. In 4:44 'a' a symmetrical section with its straight datum (no camber) has the strip at 45°, but at 'b' a cambered section requires the strip to be tilted down slightly.

## Trailing edges

Here again, ready shaped strip may be used, with the same proviso that the ribs will match up to it; otherwise it may need sanding down, when the strip might just as well have been shaped by the builder in the first place.

If the ribs are let into notches in the trailing edge, they form a stronger joint and are held accurately upright and correctly spaced. Remember that the ribs have to be measured back into the notch, not just to the front of the trailing edge strip as explained in 4:45. Partly tapered trailing edge strip with notched ribs as seen in 4:46 carries with it the chance that the covering will not be even.

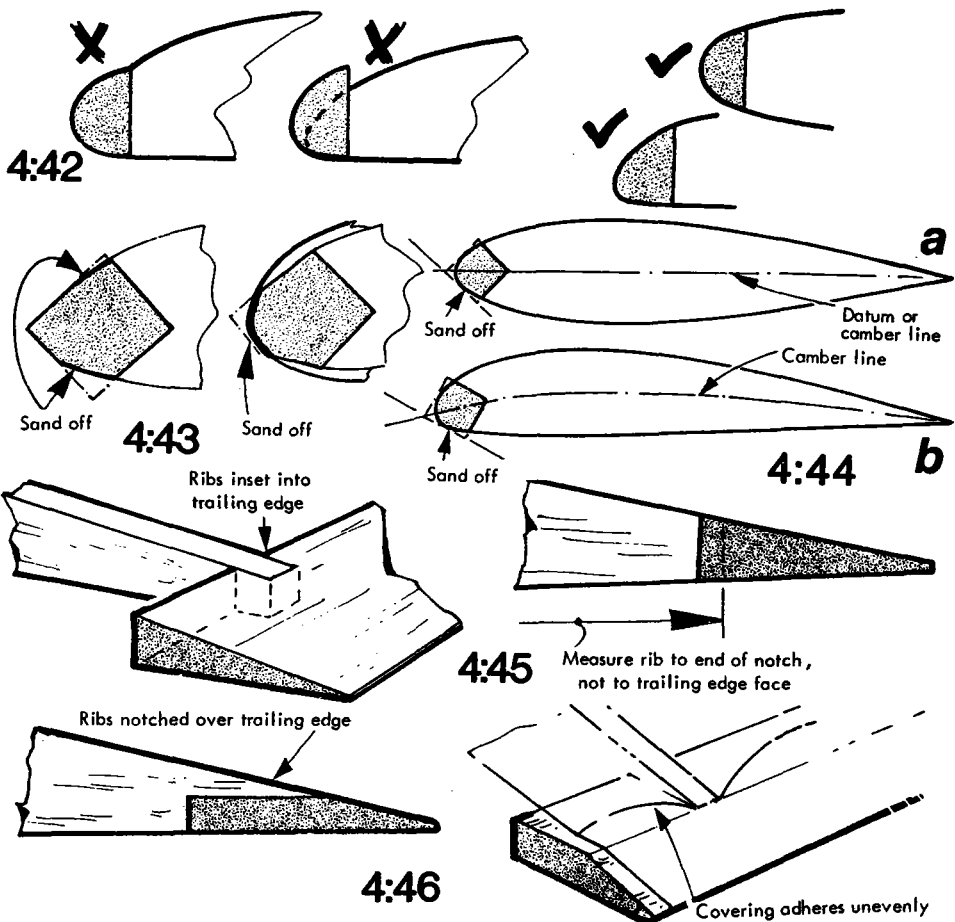

Light rigid trailing edges can be built up from thin sheet, using the ribs as angular spacers, and webs to stiffen the forward edges, as in 4:47. The lower strip is usually chamfered to form a seat for the upper one. This is best done along the edge of the bench or suitable straight edged base, with the aid of a sanding block. A line can be marked to indicate the limit of the chamfer as in 4:48. Do not use heavy pressure or the strip may curl up. Should this happen, turn it over and stroke it firmly with a plain block of wood to restore it.

Rib spacing should not be more than a couple of inches apart on, say a 6in. wing chord, particularly if the surface is intended to be well cambered. 4:49 shows how tissue, film or fabric covering shrinks down to form a series of flats, so spoiling the correct aerofoil section.

Small ribs known as riblets can be introduced between the main ribs at the leading edge to support the covering as shown in 4:50, which also indicates the normal sequence of assembly of an open frame wing.

Covering sag causes the aerofoil section to change to a smooth but thinner form, when the wing is as sectioned in 4:51 (our old friend the single central spar type).

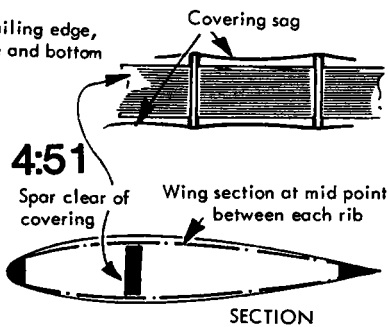
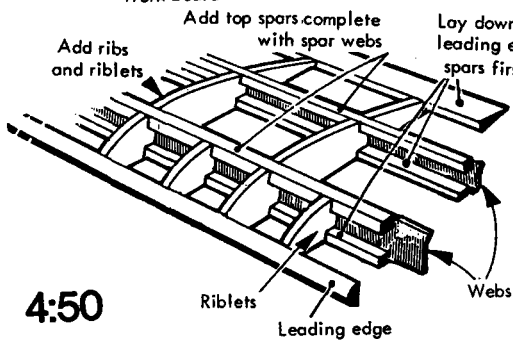
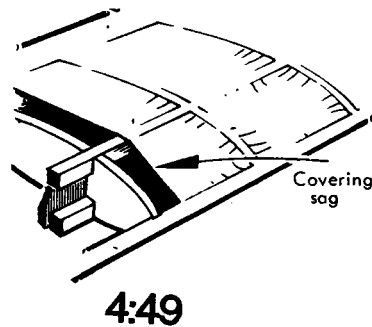
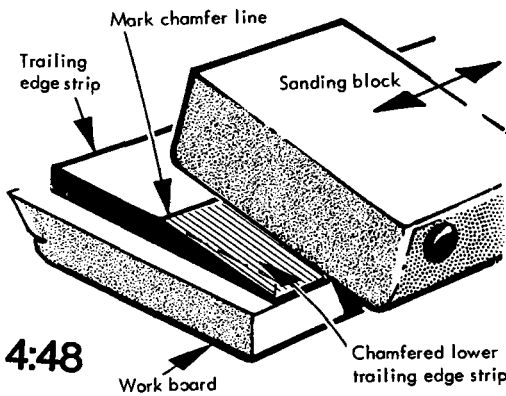
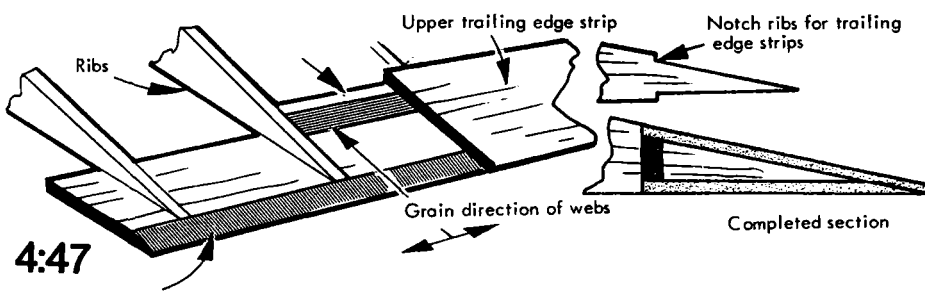

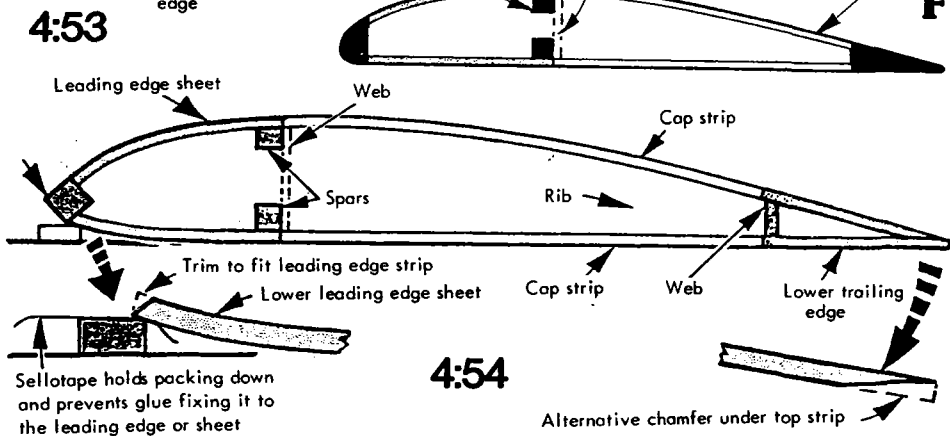
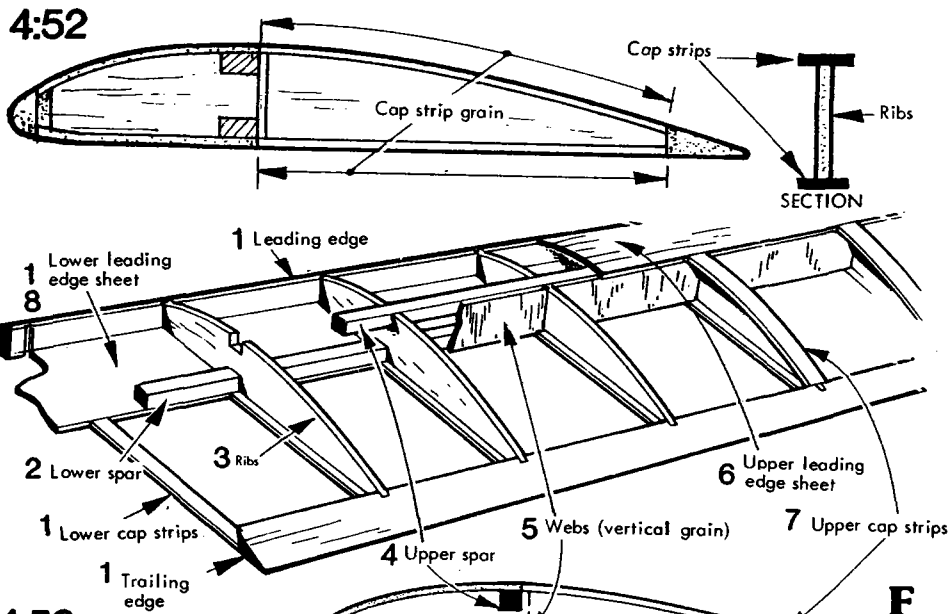

## Cap strips

Ribs may be made more rigid by the addition of strips of balsa along top and bottom edges as seen in 4:52. The strips bend smoothly over the gentle curves of the rib and provide more surface for the attachment of the covering material. Each rib becomes an 'I' beam and the covering is lifted clear of supplementary spars. Sketch 4:53 shows the order of assembly and identification of the various parts of this typical sports model wing. It has been given a sheet covered leading edge part, which converts the whole of the wing forward of the spars into a rigid 'D' shaped box. The sheet also supports the covering and affords a smooth accurate aerofoil section where it is important to have a 'clean' airflow.

Now, a tip for building on the lower sheet when it sweeps up to meet the leading edge . . . Try the method in 4:54, which is useful where the lower leading edge sheet butts up to the leading edge strip. Glue will probably run out of the joint and leave gaps so a strip of Sellotape restrains it and keeps it off the packing, to which it might adhere.

However, if the leading edge is laid on top of the sheet, which is cut

oversize, the job is a little easier during the gluing stage. Refer back to chapter 2 for sheet to leading edge joints.

The order of assembly inevitably brings a distinctly 'hedgehog' appearance, as the necessary pins are used to hold things while the glue sets. 4:55 may help in deciding which pins go into the building board and which into adjacent components. Never pin close to an edge; if the pin is to pass through the wood . . . a split will result. Pins can be used to press against the edges of parts, as in the fixing of cap strips, for example.

Always withdraw pins, which go through a glue joint itself, before the glue has hardened. If they are there just longer than the time it takes for the joint to remain undisturbed without parting it is long enough. If they are left in too long, they will stick and may break the wood surrounding them as they are withdrawn. Stubborn ones may respond to twisting axially with pliers, but if they are glass headed, grip the shaft, not the head!

Spar webs may be sprung into place by arching them gently, so as not to wipe the glue off their ends (4:56).

### Tapered wings

The ribs have to be progressively smaller to match the taper and if a 'sandwich' block method of rib production is used, (chapter 2) they must be equally spaced. Sketch 4:57 explains.

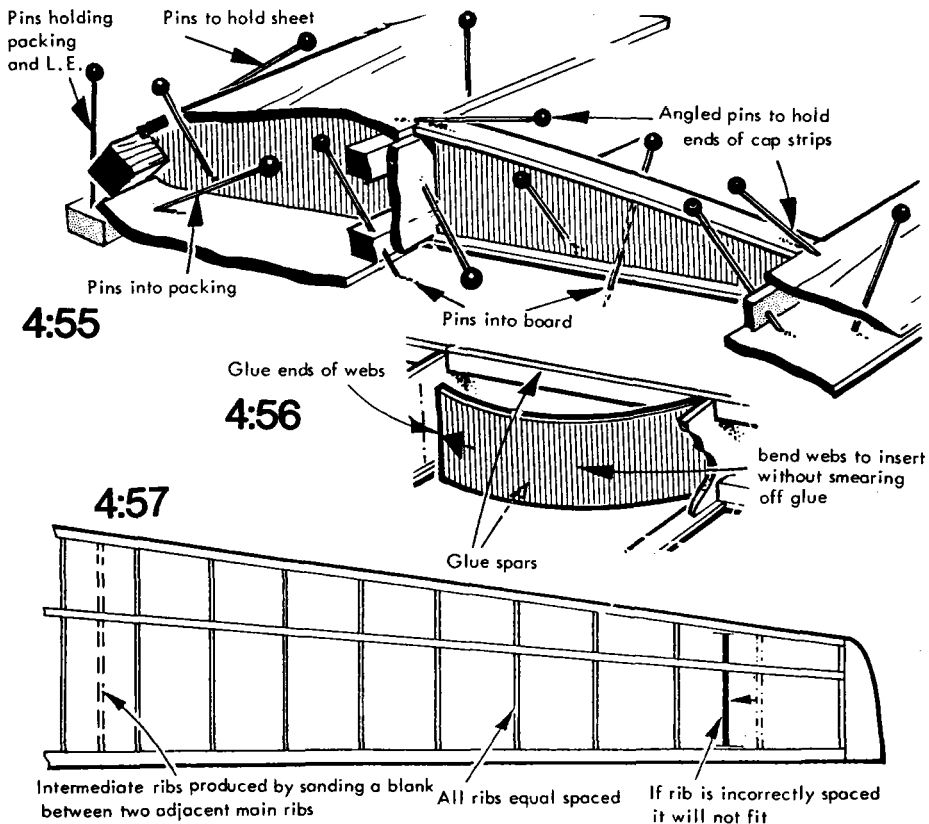

Suppose the wing panel is longer than a standard length of balsa . . . The inevitable joints in leading, trailing edges and spars need to be staggered and as near the wingtip ends as possible. This is to avoid the highly stressed inboard areas. Make sure that two splice joints do not coincide on the spars, all as shown in 4:58.

The methods of forming splice joints is seen in 4:59. This 'V' joint requires that the knife cuts are vertical and matching. Using one piece to act as a guide helps here. Remember to allow slightly more length than the joint occupies, so that any corrective trimming and fitting still leaves adequate length for the job. Never use a plain butt joint on spars, unless there are other forms of local reinforcement. A simple single splice may be made where there is less strain on the joint. This appears in 4:60. The flatter the angle of splice, the stronger it will be, so as a guide length should be at least twice the width. One accurate sawcut will automatically align both meeting faces when one strip is turned round to form the joint. The strips have to be rectangular or square in section and the cut vertical.

Pre-shaped trailing edge strips need to be turned so that both their forward faces are vertical before making a single vertical sawcut as in

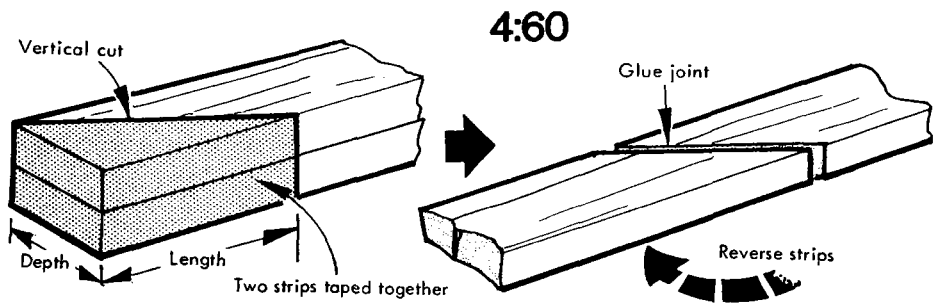
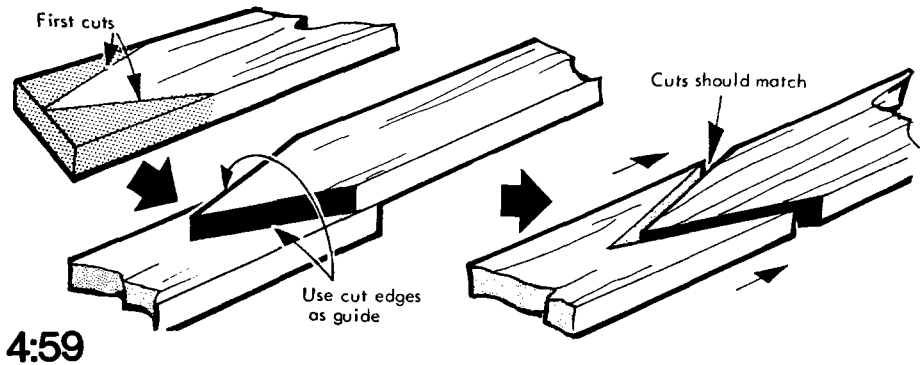
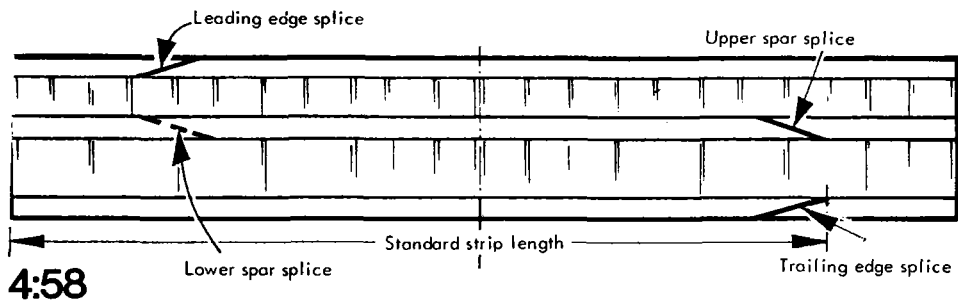

4:61

One sawcut

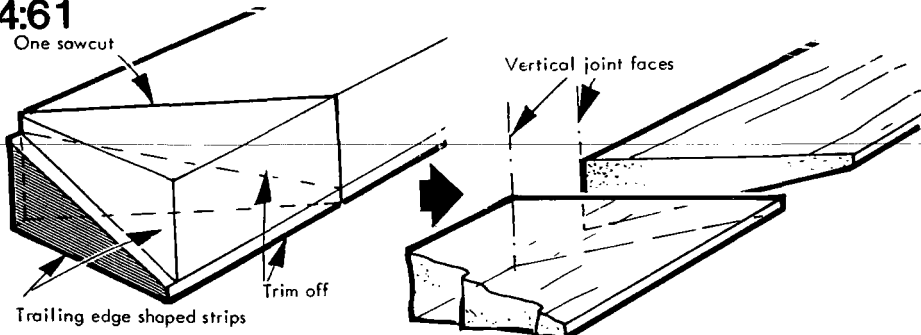

4:62

Mark lower strip

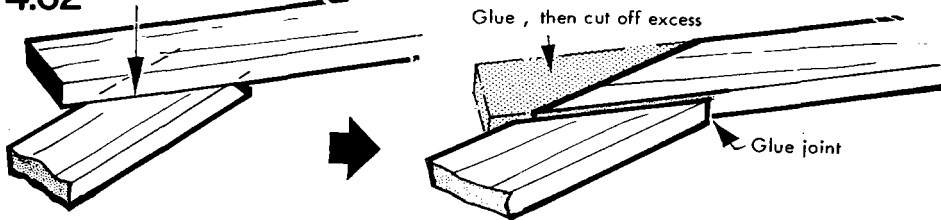

4:63

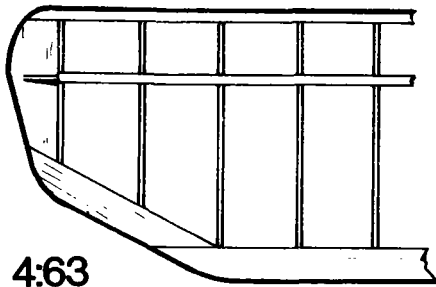

4:64

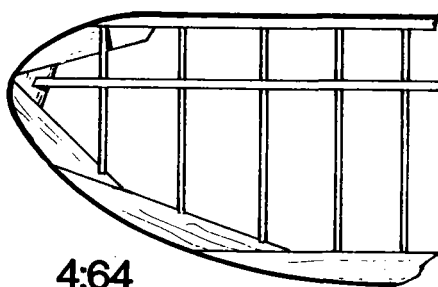

4:61. Failure to do this will result in the meeting faces being out of vertical and not matching when the strips are laid flat again.

### Tip tips

The extra span can be the excuse for changing the shape of the wing planform at the tips, so trailing edge strip becomes angled to reduce the chord. To make this joint lay the second strip under the first and use it as a guide to cut a chamfer in the new piece, then when joined and set, trim off the excess of the first strip – see sketch 4:62.

Tips do not have to be elaborate to be attractive. Choose the angle to please the eye, within the practical necessity of having the intended wing area and tip chord. Just one angled trailing edge strip and a sheet panel at the extreme tip as shown in sketch 4:63 will do nicely. On small models few ribs will need to be trimmed or special ones cut. A gusset supports the top panel and unless there is a deeply undercambered wing section, it works for a variety of models. A good version for flat bottomed or symmetrical wings, this.

Sketch 4:64 shows a more subtle version with several strips forming the tip outline. Trim back to the required outline edge after assembly.



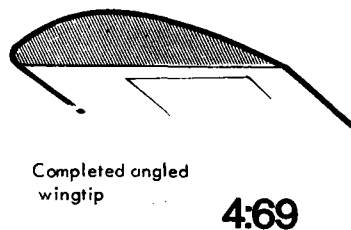
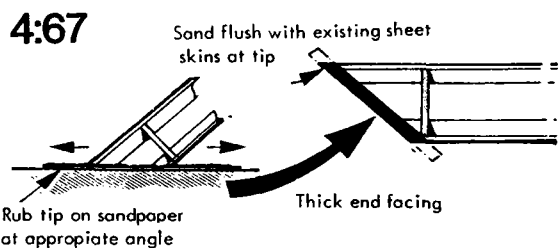
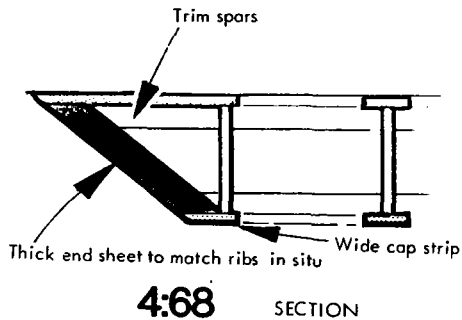
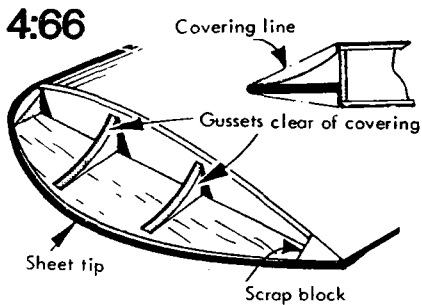
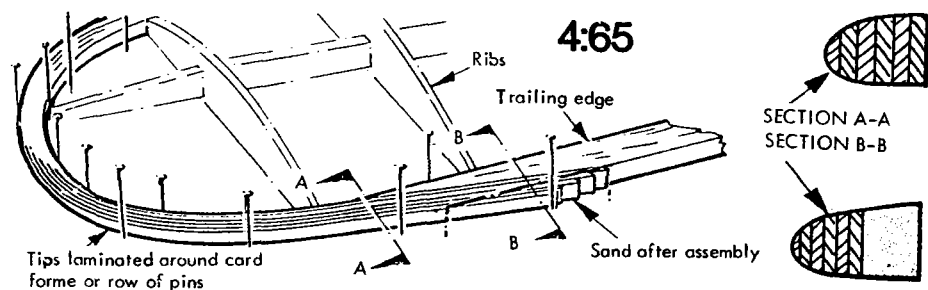

Lightweight models can be given laminated strip tips as shown in 4:65. The section of each strip will depend on the type of model i.e. a light rubber powered model could have  $\frac{1}{32}$ in. x  $\frac{1}{8}$ in. deep strips, whereas a radio controlled or control line model with a chord of over 8in. might need  $\frac{1}{16}$ in. x  $\frac{3}{8}$ in. Note how the tip laminations are blended into the trailing edge. It avoids too sharp a radius near the end of the laminations. Put those strips together one at a time. Another tip is to make a double depth tip and carefully divide it down the centre with a razor saw to make a pair.

Parallel chord or tapered wings can be given a simple shaped tip made from sheet, suitably gusseted as in 4:66. Those gussets may be cut back to just clear the covering line, which gives a smooth finish.

If the wing is chamfered at the tip, it will form a curved wingtip . . . a product of the aerofoil section exaggerated as in 4:68. Run the spars and leading edge sheet past the intended tip line and sand it at the required angle, face it with sheet and trim . . . Result, a simple, attractive and practical wingtip as seen in 4:69.

Many duration (free-flight or radio control) models have polyhedral wings to aid stability; such a wing is shown in 4:70. The angles of each panel will vary from model to model depending on its type, low angles

4:70

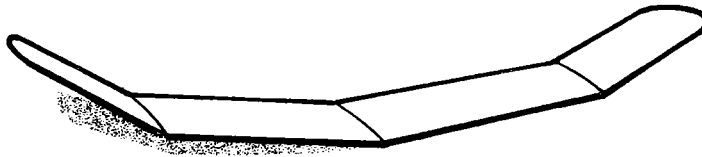

4:71

Double width notched rib  
Spars overlapped and glued

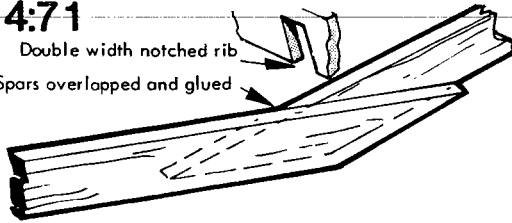

4:72

Tip ribs have notches further forward or aft of main panel

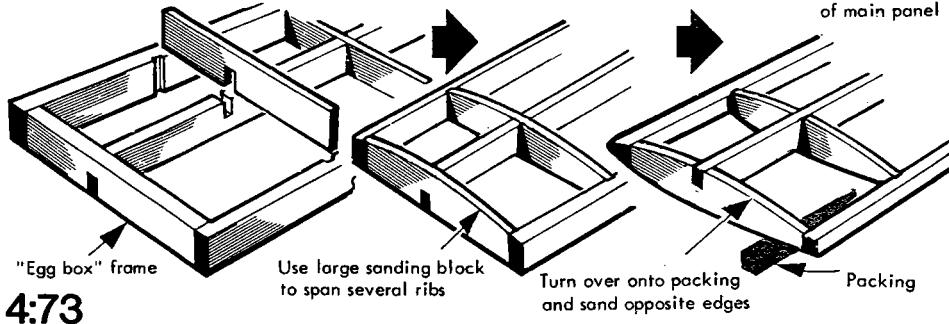
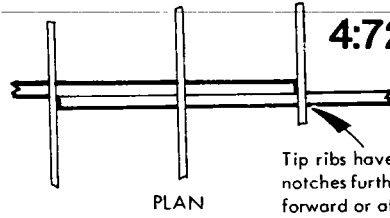

4:73

"Egg box" frame

Use large sanding block to span several ribs

Turn over onto packing and sand opposite edges

Packing

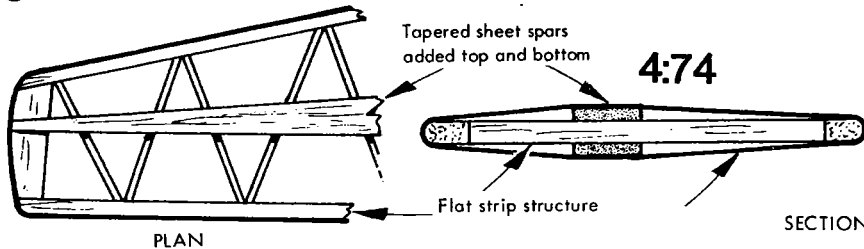

4:74

Tapered sheet spars added top and bottom

Flat strip structure

SECTION

for radio control, steep for free flight, steeper still for sport free flight, where efficiency is not the prime motive, but ease of handling is desirable.

Spars can be overlapped at the joint to form a sound joint without further reinforcement. This means that the rib or ribs at the joint need wide slots to take the spar joint and those ribs outboard have to be notched to suit the tip spar, rather than the inner panel spar. Sketches 4:71 and 4:72 show this detail.

### Tailplanes and fins

The average model can manage with a tail surface section which is often less carefully contrived than the wing. In the past the tail area was much larger than nowadays (in relation to a given wing area). Then one had to use an efficient lifting section . . . often to the detriment of the model if it became more efficient than the wing and put the nose down 'for keeps'!

Sketch 4:73 shows how to make a simple built-up tail (tailplane or fin) . . . Be sure to use firm packing under the already shaped ribs when LIGHTLY sanding the other side. A flat strip framework can have external spars which give it a rough approximation of a bi-convex section. You can use it on control line wings too. It appears in 4:74.

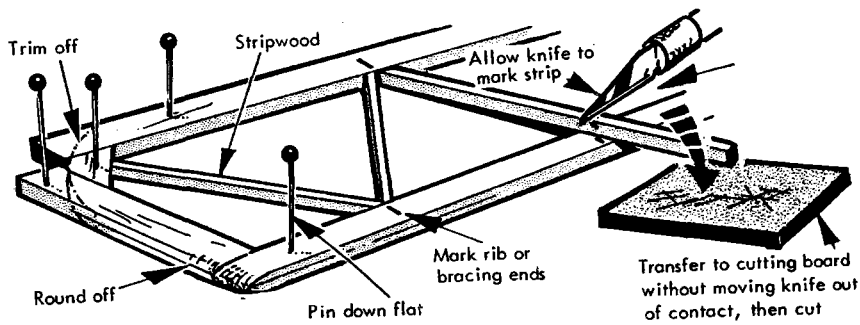

4:75

SECTION

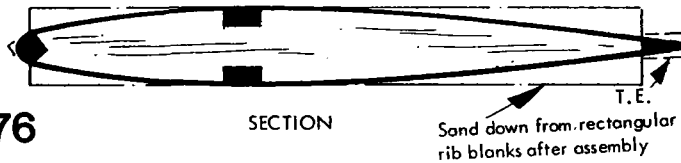

4:76

SECTION

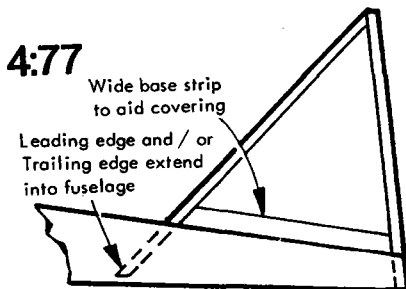

4:77

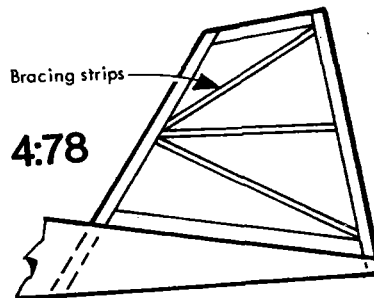

4:78

For something lighter; stripwood flat plate tails are satisfactory, but take care in covering them, they are prone to warps. Diagonal bracing makes them more rigid. Cutting those strips accurately can be a chore, but a tiny portable chopping board can be helpful. Lay the knife in the strip where it crosses the intended joint and transfer it to be cut as seen in 4:75, along with general tips on assembly.

Deep 'rib' or diagonal strips can be used, having propped up leading and trailing edges to make a framework as in 4:76, then sanded down fore and aft to make a smooth aerofoil. Always use a sanding block that spans three or four rib bays, which enables the ribs to be shaped evenly. Spars provide a guide when sanding, but avoid thinning them in the process.

Small, light models can have open frame fins of very simple shape, but they are generally fixed permanently to the fuselage, for consistent flight performance.

This means that a deep base strip is desirable to aid the covering process. The fin can derive support from the fuselage by running its leading and trailing edges down to meet the bottom or a suitable former as seen in 4:77. Where fins have to be fixed to the tailplane, the extensions of L.E. and T.E. can go between two ribs.

The triangular shape is twist free, but more rectangular or rhomboid forms can be braced as in 4:78.

# CHAPTER 5

## Mounting the engine

- Profiles
- Bolt locking
- Pylons
- Plate mounts
- Bearers
- Twins
- Radial mounts
- Tank installations

See also Chapters 2, 3, 4 and 6

Simplicity is the key for profile models, whether free-flight, control-line or even radio control. The bearers contribute to the structure of the fuselage and are reinforced with ply doublers as in 5:1. Normally the bearers are deep enough to accommodate the crankcase, but wherever possible the doubler under the engine should go right across, even if it means interposing a packing strip under the bearers.

### Bolts

Slot-head bolts can be damaged to a point where it becomes difficult to tighten or slacken them. The culprit is often the wrong sized or badly

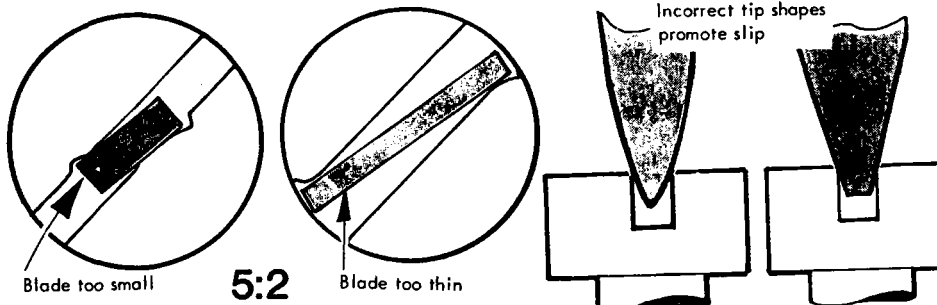
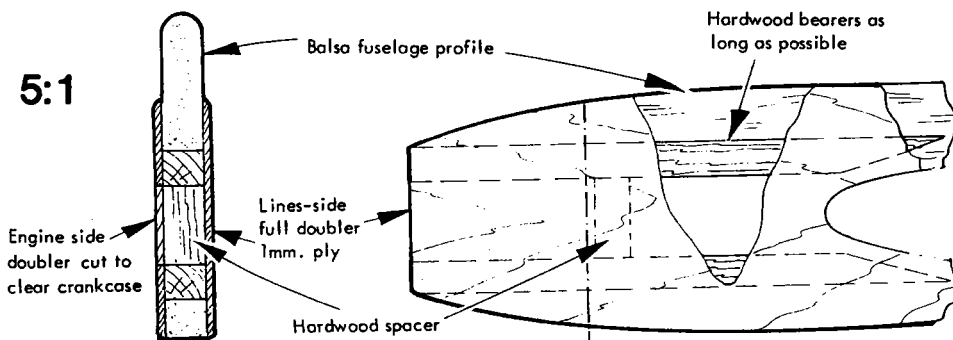

ground screwdriver. 5:2 shows four of the little blighters. Please make sure that the blade fits properly in the screw head.

Instead of relying on tightening the bolts, or where they are to be made inaccessible within a cowling, nuts do the clamping and the bolts are locked. Sketch 5:3 suggests hard soldering them to a brass strip. This is fine for smaller engines, but for a more substantial job, try that shown in 5:4, which also works with hexagonal head bolts.

### Profile pod

Control line combat models may have no more than a couple of bearers sticking out of the wing. By opting for a pre-assembled bearer/doubler/filler unit, the engine should be more rigidly secured and as a result, run better. Such a unit is shown in 5:5 and would be epoxied to

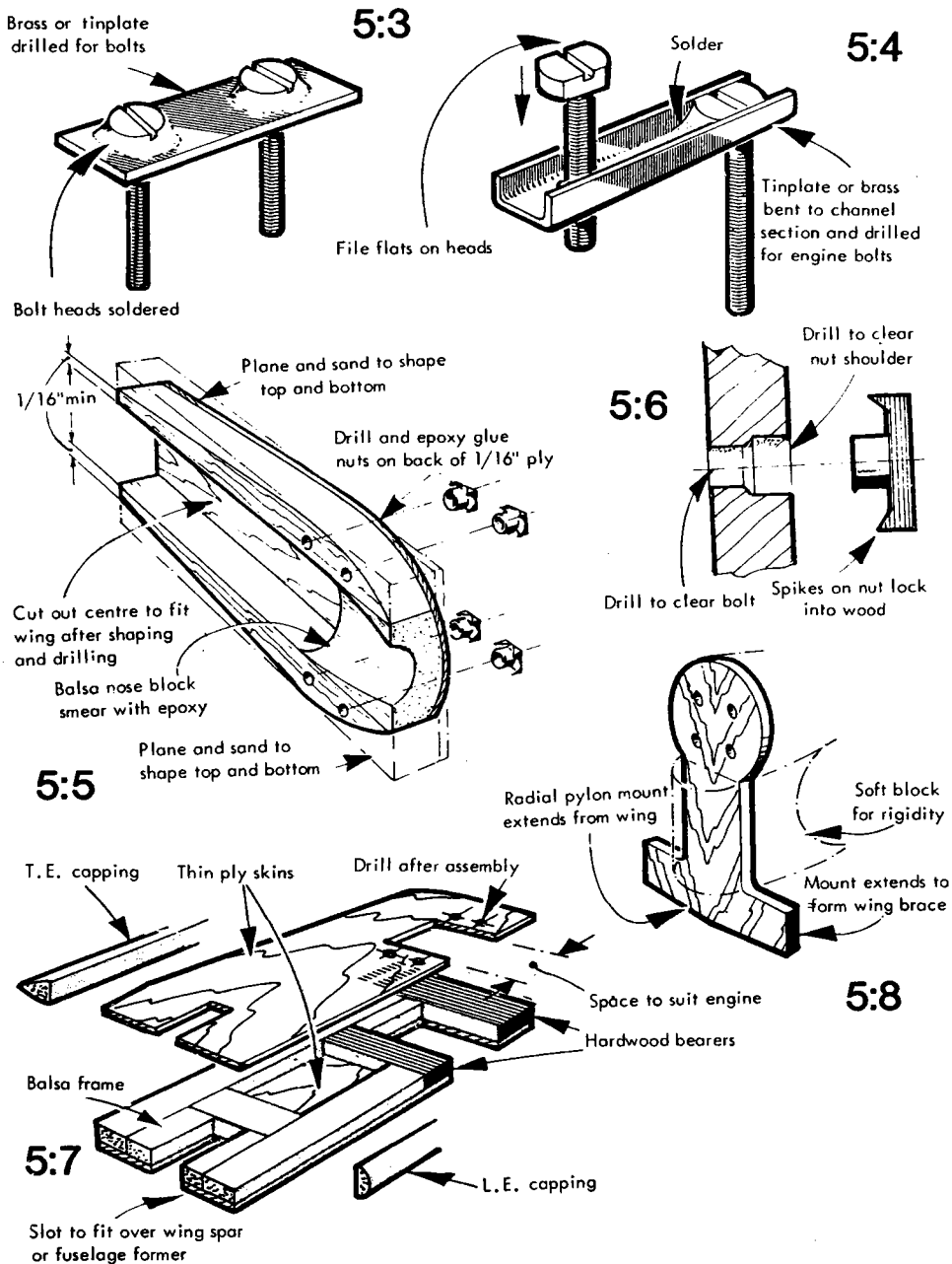

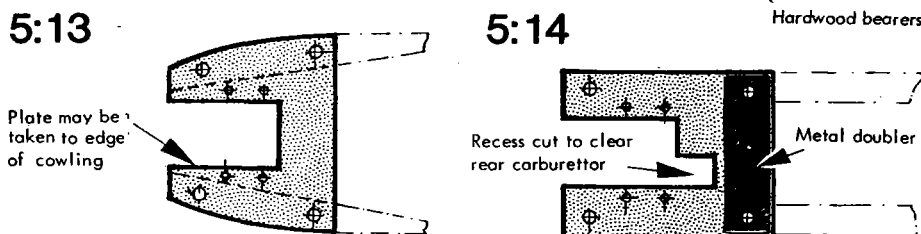
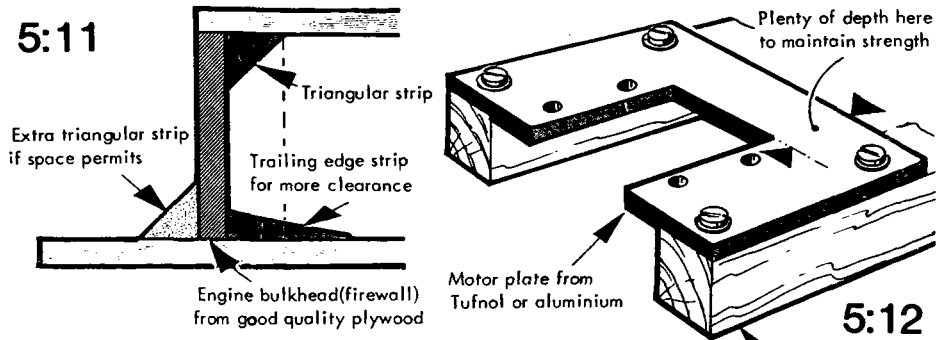
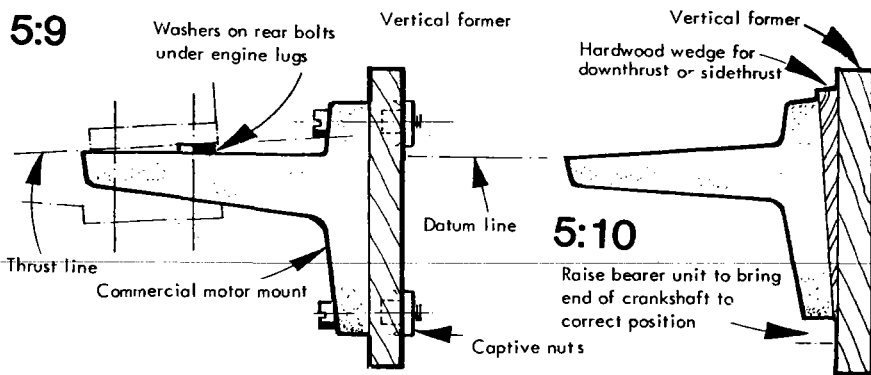

thick centre rib and short section of leading edge sheet or gussets. This example shows captive nuts (sometimes called 'blind' nuts). They bite into the wood and can be additionally secured with epoxy.

Make sure that the bolts are greased so that any epoxy creeping onto the threads does not lock them. If they are then to be locked, de-grease them and use thread locking compound. Sketch 5:6 shows how to recess the captive nuts.

## Pylons

Power assisted gliders sometimes have a small engine mounted above the wing on a pylon. There are commercial pylons and band-on metal ones, but two wood designs are shown in 5:7 and 5:8. The former is for beam mount engines and the latter for radial mount types. Both key into the wing or fuselage former.

## Radial mounts

Commercial radial mounts are available in many sizes for beam mount engines. They can be bolted to a thick ply former or 'firewall' with captive nuts. Downthrust can be incorporated by fitting washers under the rear lug of the engine (5:9) but a better method is to mount the radial mount on a wedge shaped hardwood plate, or angle the firewall itself. Remember to raise the mount to keep the engine shaft in line with the spinner position (5:10).

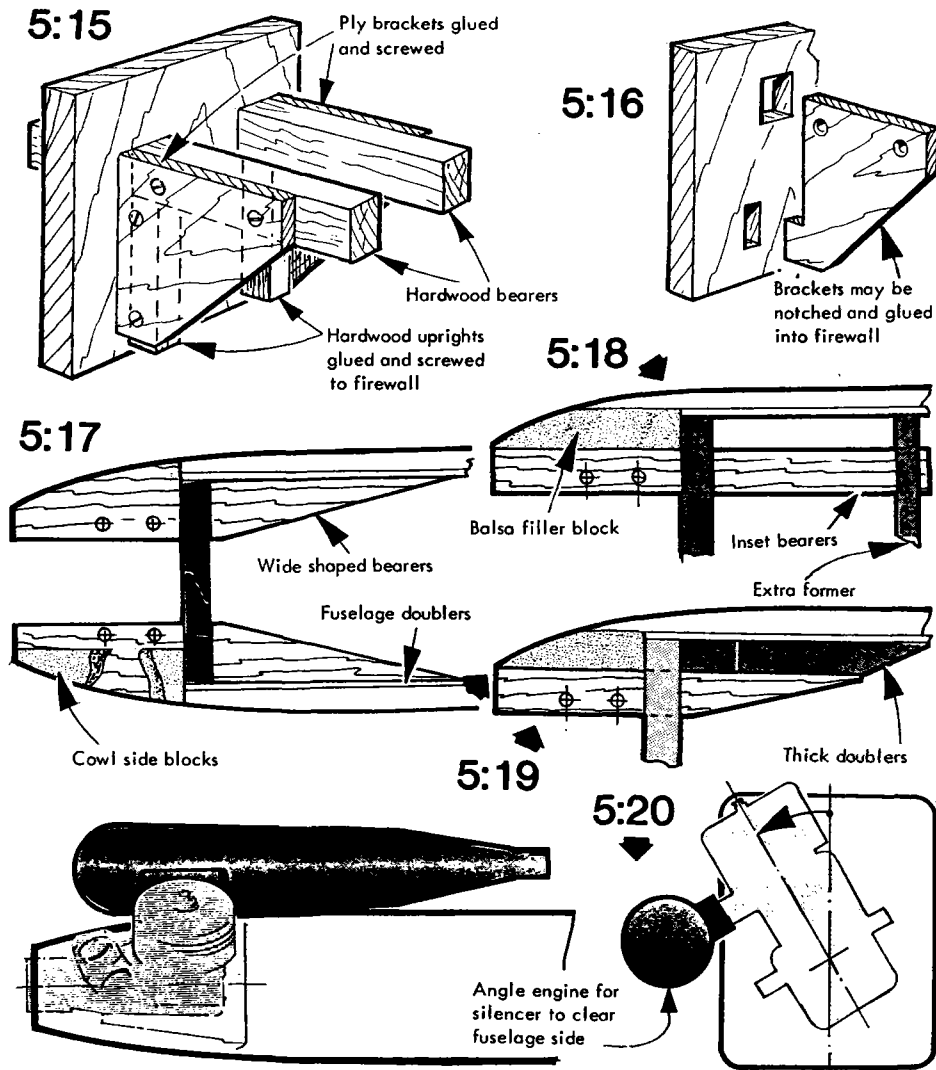

There is a powerful twisting force at the firewall due to the overhang of a radial mount, so add reinforcement where the firewall meets the fuselage as in 5:11. One or both side sheets can be extended to form cowl sides and there is plenty of room for a fuel tank.

### **Bearer plates**

Where the fuselage is wide enough, the engine may be bolted to a flat plate of Paxolin, Tufnol (which is stronger) or aluminium. In a mishap, this plate breaks, thus saving damage to the engine and (hopefully) fuselage. Different size engines may be substituted and sidethrust can be altered by using different plates, see 5:12.

The plate can follow the fuselage sides as in 5:13, but may need a metal doubler strip should it have to be notched deeply around a rear positioned carburettor (5:14).

If bearers have to be short, add ply gussets as in 5:15. Hardwood strips on the firewall offer gluing area and take woodscrews to make those brackets really secure. On small models, such brackets can be

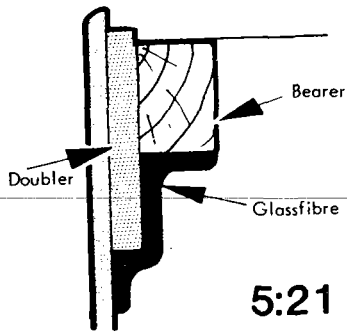

5:21

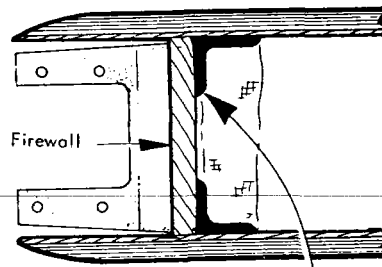

5:22

Glassfibre reinforcement

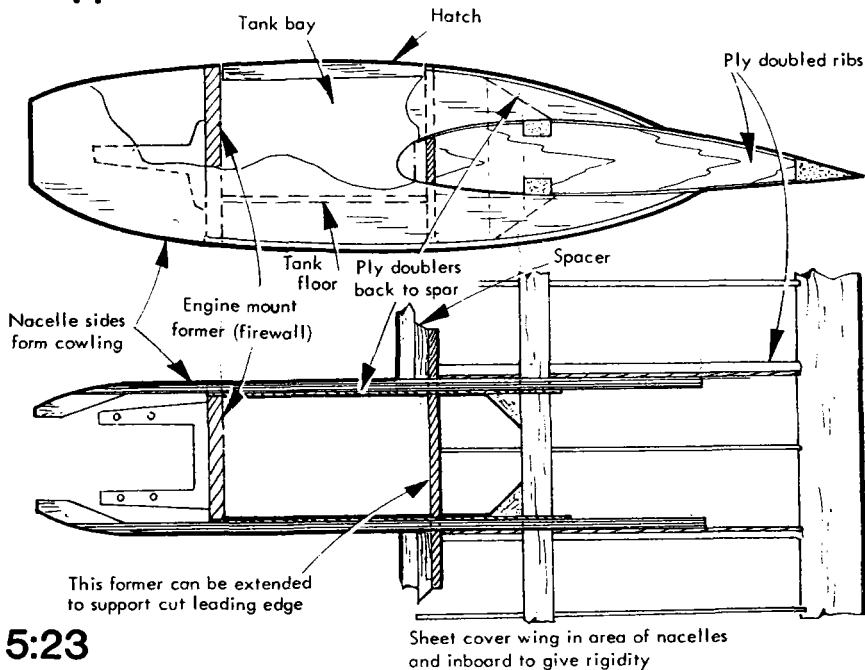

5:23

1470: 5:23

notched into the firewall as shown in 5:16. Wide bearers can be glued to the fuselage sides or their doublers as seen in 5:17. The front ends can be shaped to meet the cowl front or spinner and offer support for the cowl side blocks. Inset bearers need a second former aft and derive support at the front via filler blocks in the extended sides of the fuselage (5:18). If the bearers taper off, they gain support from doubler/filler blocks behind the firewall as well, as 5:19.

Provided there is adequate space to install and service the engine, the fuselage sides may extend well forward as part of the cowling and to support the bearers. While discussing accessibility, remember that the engine need not be upright, side mounted or inverted . . . Angle it just enough to allow the silencer to clear the side as in sketch 5:20. Radial mounts permit this angle to be adjusted if the engine is changed.

### Glassfibre bonding

When bearers are bonded onto fuselage sides or doublers with epoxy, it is a worthwhile job to lay in some glass fibre cloth with more epoxy to gusset the joint as seen in 5:21. Remember that polyester resin, as used in most glassfibre repair kits, does not bond properly to epoxy and vice versa. Either put the bearers in with polyester resin first



or keep it all epoxy. However, if no epoxy is smeared on the exposed surface of the bearers or firewall, the polyester resin will be unaffected and will bond onto the wood.

Firewalls can be treated in this manner as in 5:22, very useful when there is lack of space in the tank area.

### Twins

Twin engined models may use commercial radial mounts on firewalls spaced out on nacelles (like short fuselages), these being built onto the wings by taking the sides back against strengthened ribs or onto the spar system. Sketch 5:23 illustrates the general idea. Refer back to 5:1 and 5:5 for profile nacelles on control line machines.

Hardwood bearers can tie the nacelles in to the spars as seen in 5:24 for upright or inverted engines. The nacelle sides aid rigidity and a former fixes to the wing leading edge. The load can be spread well into the spars, even if the bearers are arranged for side mount or upright, by use of the detail in 5:25. This is particularly useful if the thrust line is not in line with the spars.

### Tanks

Before leaving twin layouts, remember that each nacelle needs its own tank, so make room for it. The prime features of good tank

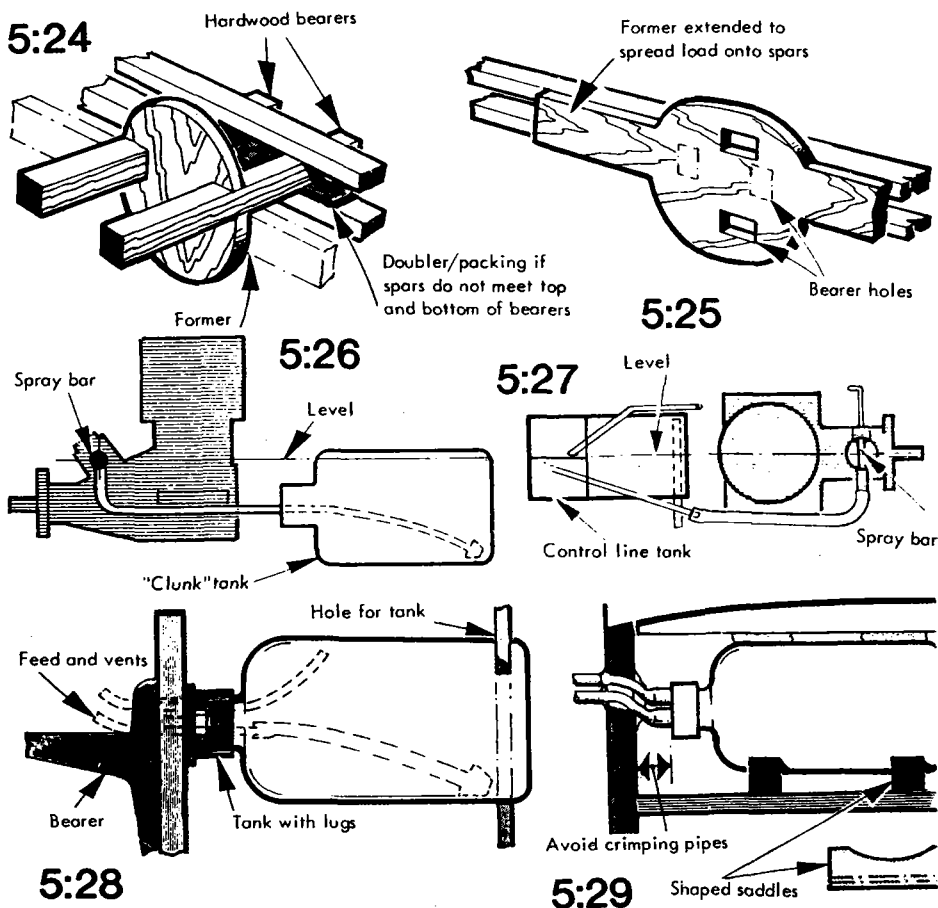

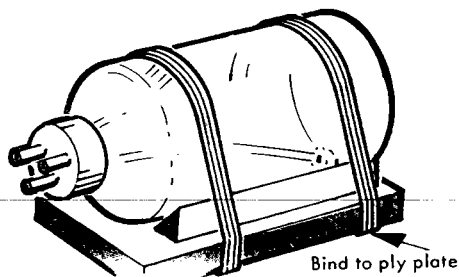

5:30

Nylon tube heated to bend

5:32

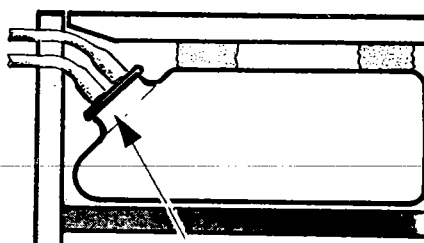
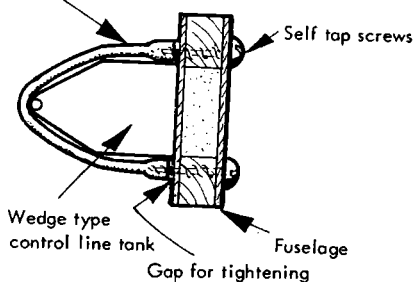

Angled bung convenient

5:31

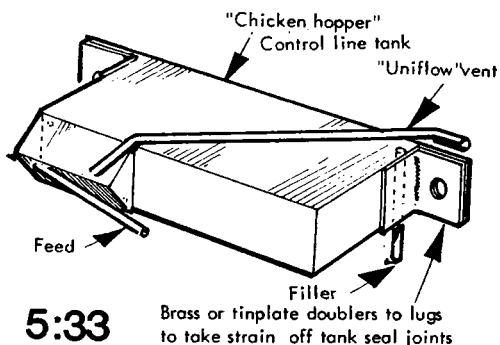

5:33

Brass or tinplate doublers to lugs to take strain off tank seal joints

installation are (1) the fuel level when full should be level with the actual spray bar hole in the carburettor for radio control or sport free flight models (5:26). On control line models the centre of the fuel pick-up point has to be in line with the carburettor, as in 5:27. (2) The tank should be accessible for cleaning or replacement. (3) It should not be loose in the model.

For radio control models, it will be seen that the tank bung can partly support the tank, and the end of the tank held in a pierced former (5:28). More accessible is the bay in 5:29, where a removable lid clamps the tank onto saddles. Silicone rubber caulking around the pipes where they emerge through the firewall stops fuel seepage.

Some round tanks tend to rotate with engine vibration, kinking the tubes in the process, so bind them to a ply plate loose in the tank bay, held by the lid as seen in 5:30. Rectangular tanks are available for radio control with the same 'clunk' action, and some have angled bungs which permit better access when installing in a bay with a top hatch. Packing can be added below tanks to bring them to the correct level, but if the floor of a tank bay is too high, the tank cannot be lowered sufficiently by taking out packing, see 5:31.

### Control line tank mounts

A profile model can have its tank strapped to the side with a piece of nylon tube heated to bend and secured with self tap screws as in sketch 5:32. Those tanks with their own lugs benefit from an extra layer of metal to reinforce the lugs and resist the load on the tank sealing solder joints, see 5:33, which illustrates a 'chicken hopper' type of tank. These methods of mounting can be used, where the tank position allows, on an internal installation. The bolts or screws pass through the fuselage side and doubler.

# CHAPTER 6

## Better fuselages

Improved box fuselage  
Shaped decking  
Doublers  
Curved skins  
Stringers  
Planking  
Rolled construction

See also Chapters  
4, 5, 7, 8 and 20

Basic boxlike fuselages can be dressed up by changing the shape of the outline and/or fittings, adding cowlings and canopy of attractive shape and even modifying the colour scheme. Compare the plain 'plane in 6:1 with that in 6:2; the basic box has not been changed.

### Composite box

Now let's try mixed construction: ply at the front where it takes the rough handling and balsa aft where it has to be light (6:3). The joint

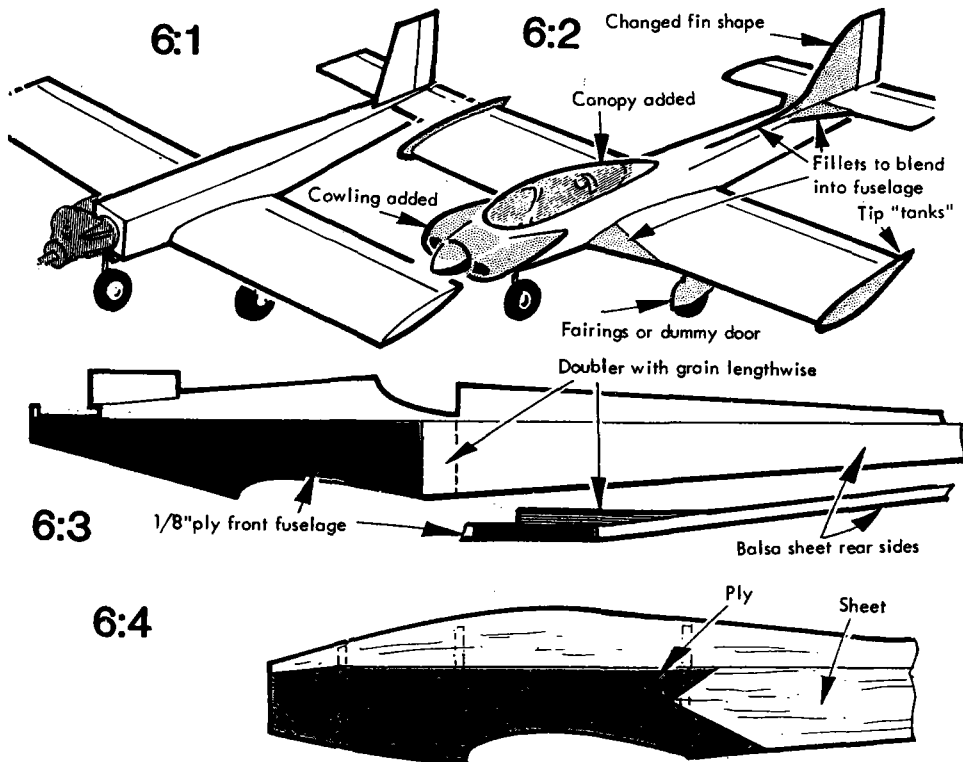

between the balsa and ply needs a reinforcing piece behind as shown, but small models can be strong enough with a carefully made splice joint as in 6:4.

### Strength where it is needed

Although the more basic fuselage needs reinforcement as earlier noted, changing the shape may bring with it the need to pay special attention to local areas. 6:5 for example indicates that because there is a shaped top 'decking', balsa top parts are added to the strong main formers and along the rear fuselage to preserve the shape – these are 'secondary formers'.

### Doublers

If the basic fuselage is cut to accommodate the wing, or becomes thin where there is an area of stress, 'doublers' are needed on the inside. 6:6 gives a general idea but each fuselage will have its own requirements, for example that rear doubler could be balsa and the front one  $\frac{1}{16}$ in. ply. Balsa may be used on light models as in 6:7 with vertical grain to resist side splits, or diagonal as in 6:8 for more lengthwise strength. Contact glue is often used for fixing ply doublers, so either hinge one edge with tape (6:9) or use pins (6:10) to ensure that the doubler sticks in the right place . . . . You only get one chance with traditional contact

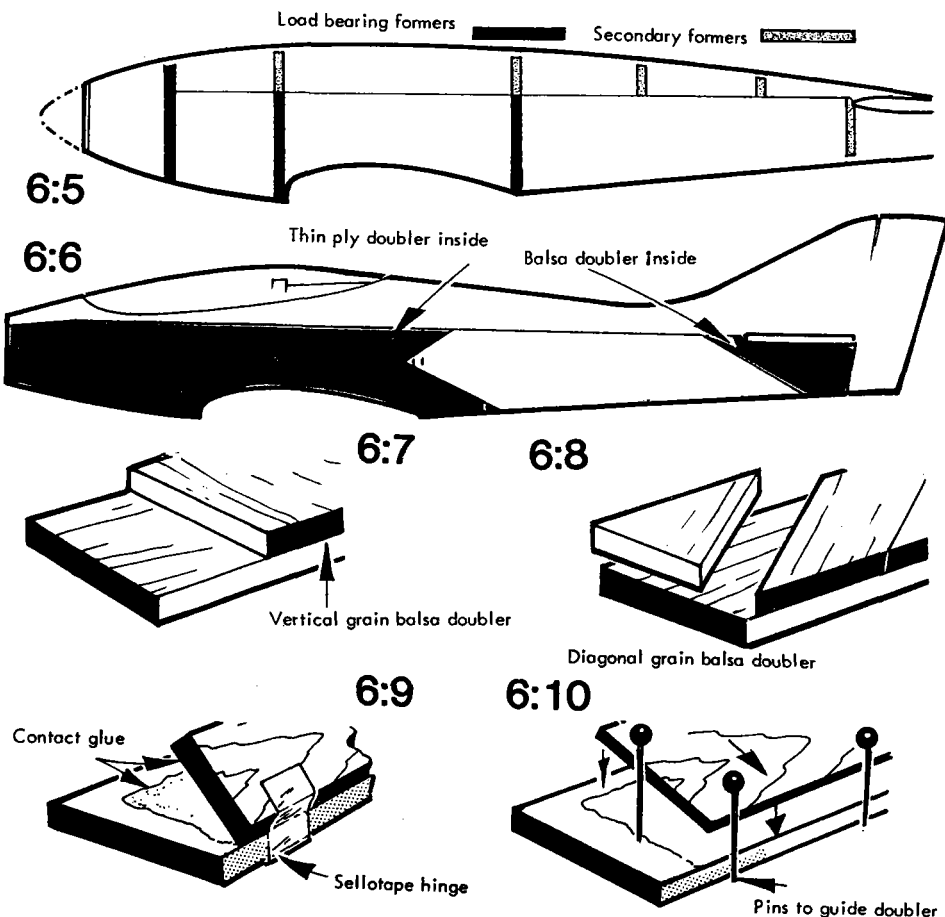

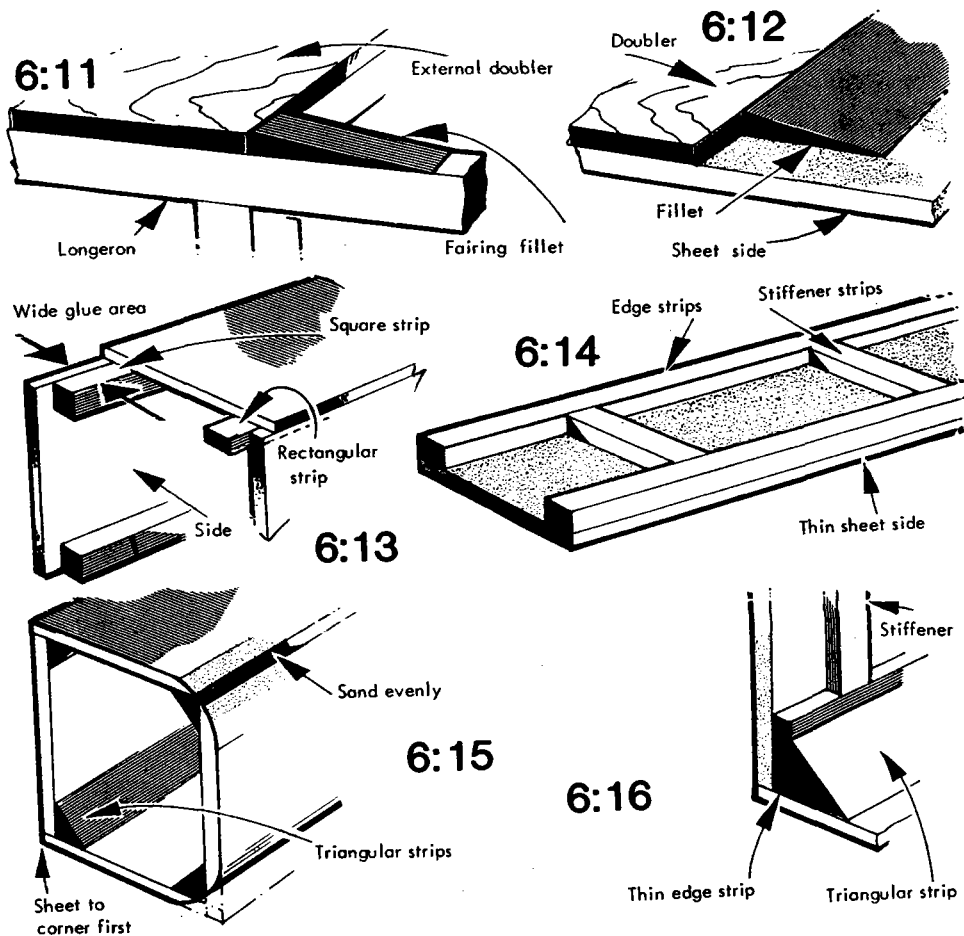

glue so do it right. Another idea is to slip a piece of paper between the glued surfaces when ready to contact, then slide it out carefully.

Some models have a thin ply doubler *outside*, leaving a step in the surface – fair this in to avoid a sudden ridge in the covering, just in the longerons of open frame structures as in 6:11 or by a full depth (or width) strip on sheeted fuselages (6:12).

### Beefed up box

Content with plain rectangular tubes? See how to improve the strength and appearance of those in Chapter 2. The glue joint between top and sides could part, so a square or rectangular strip of balsa can be added to extend the gluing area (6:13). Because they need not be classed as 'longerons' they can be as small as  $\frac{3}{32}$ in. square and medium-soft. Alternatively, the side sheet can be thin and a structure added to the inside face to make a strong panel which will hold its shape while making the fuselage proper – see 6:14. The result is much lighter than thick sheet on its own and well worth the extra trouble.

### Rounding the corners

If triangular corner strips are added, the corners can be sanded down to meet them as seen in 6:15. This has the advantage of reducing the chances of splitting near the 'corner', because the wood is nearly the

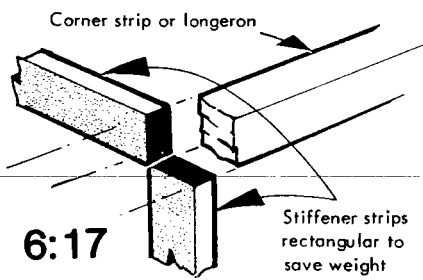

6:17

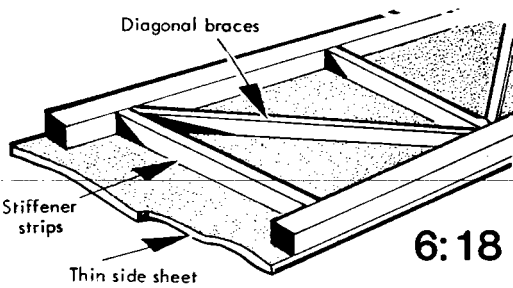

6:18

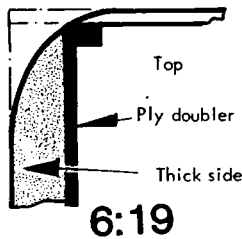

6:19

6:20

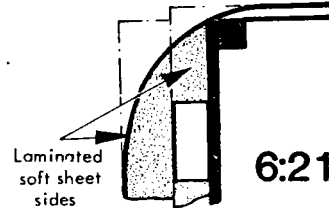
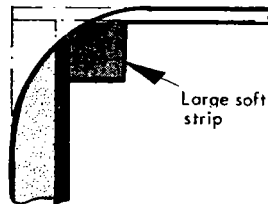

6:21

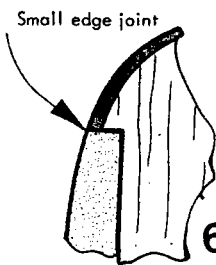

6:22

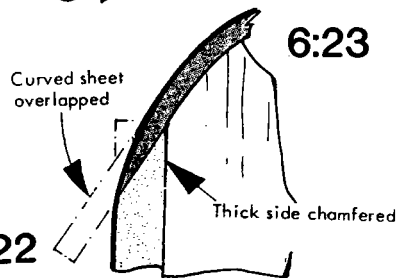

6:23

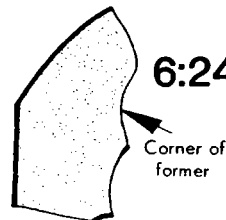

6:24

same thickness right round the joint. The triangular strip can also be added to a thin braced sheet, provided the lengthwise strips are thin (6:16).

### Lightness

Those reinforcing pieces can be even thinner in lighter models as seen in 6:17, and supplemented with diagonal bracing on thin sheet as in 6:18.

### Chunky corners

By contrast, soft thick sides teamed with thin top or bottom can be nicely rounded even with a ply doubler (6:19) provided the transition between the sheet is not sudden. In any case, all corners should be initially sharp to ensure accuracy, even if a fair amount of sheet is sanded away.

A large section corner strip or triangle section is needed for large radius corners shown in 6:20; alternatively, weight can be saved by making that soft side from stepped pieces of thinner sheet. Sketch 6:21 shows this variation.

### Raised decking

Thin curved sheet can be supported on formers to shape the top, but be careful that the joint to the side panel is sound. It will be weak if made as per 6:22. Better allow a nice chamfer to provide gluing area,

then sand off as seen in 6:23. It is easier to make the formers as in 6:24 for this detail.

Perhaps the structure does not lend itself to the foregoing details? Makes sure that the joint is pinned well while the glue dries: a block and tape also helps as in 6:25. Won't the sheet bend sharply enough? Use two thin sheets which will bend easily as in 6:26.

Is it enough to have a simple triangular top decking to the fuselage? You can play this trick on an existing box shape. Retain the top sheet and add a vertical web and gussets as in 6:27, which shows both fabric or sheet covering. A new box fuselage needs that top sheet first.

### Stringered top

This is a variation on the last idea. The strong box with a sheet top has light formers and stringers added as in 6:28 for a fabric decking.

### Curved sides

Quite thin side sheet can be given extra rigidity for no weight penalty if it is curved in cross section – try it out now with a piece of paper, as sketch 6:29. Yes, the fuselage has to taper straight from the firewall aft, or, if bent to taper aft of the wing in conventional manner, has a short uncurved area at 'b'. A former and small doubler is needed here.

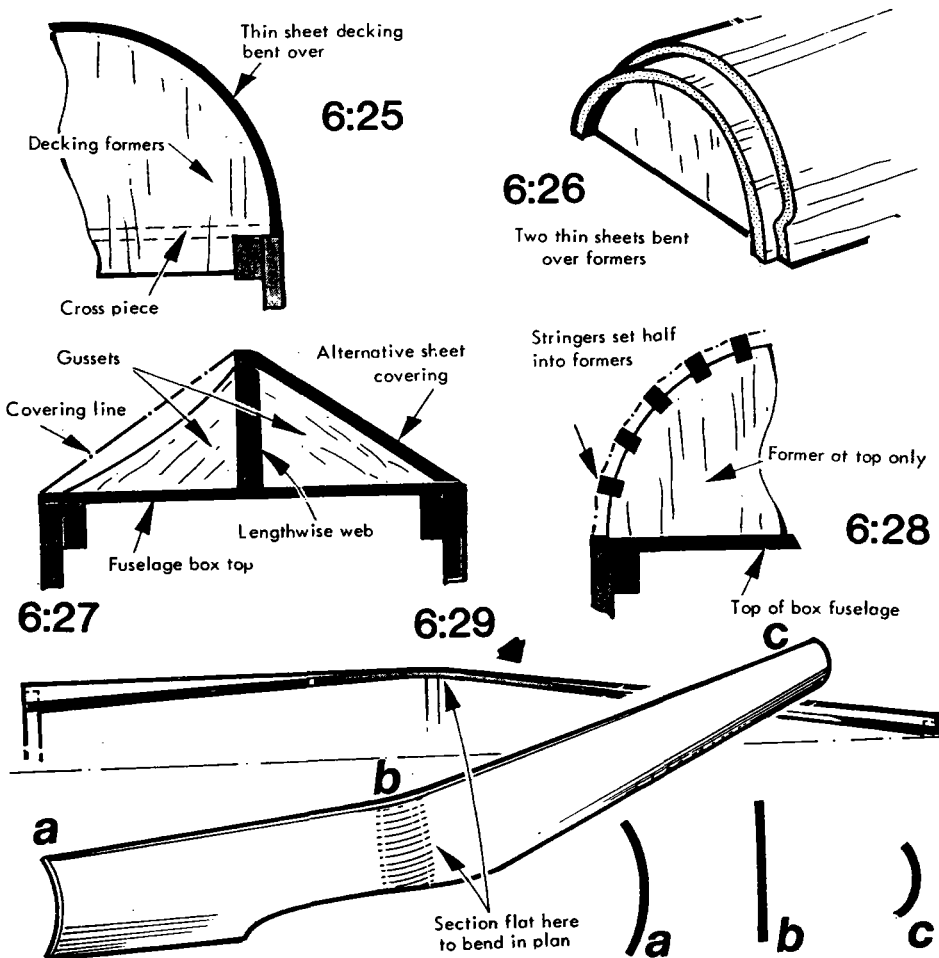

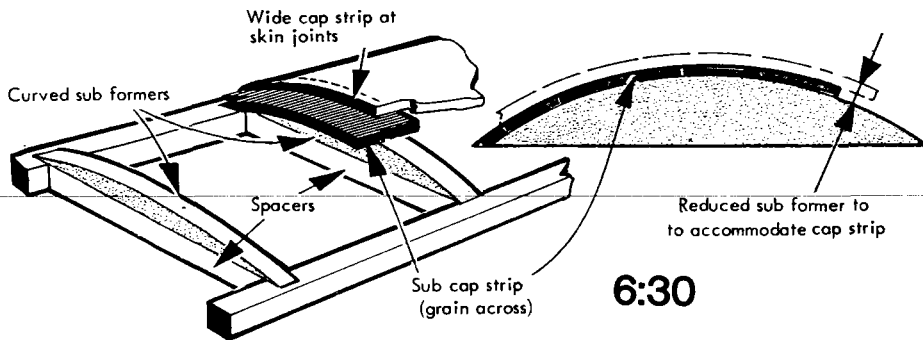

6:30

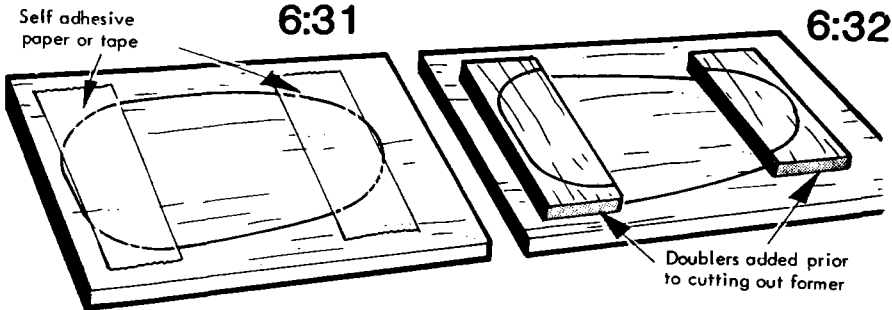

6:31

6:32

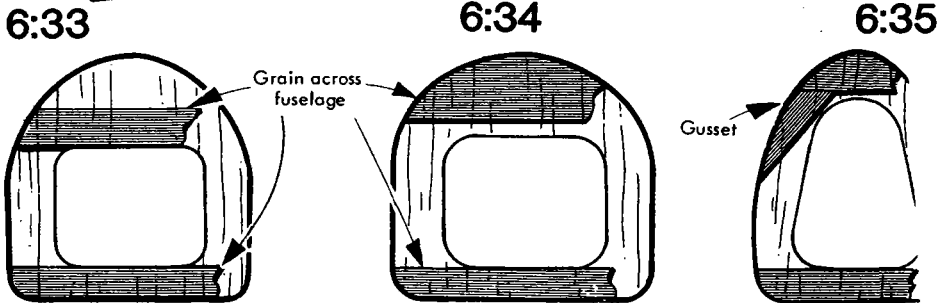

6:33

6:34

6:35

Where more strength is needed or very thin sheet is used, try detail 6:30. Take a basic open frame structure and add curved sub formers, then sheet in sections to accommodate a lengthwise curve, or semblance thereof. Where end-to-end sheet joints occur, skim down the former and add a sheet doubler with grain across its width so that it forms a cap strip.

### Notes on formers

Now that formers which are more complex in shape are called for, the following tips may be found helpful. Strips of sticky paper or tape may be laid across both sides of the sheet from which formers are to be cut, so that the cuts across the grain do not weaken them (6:31) or if doublers are to be used, they can be fixed before cutting out the former (6:32).

The size and position of the doublers, which give great strength to quite thin formers, may be judged from 6:33 where most strength comes from the sides of the fuselage, 6:34 where the top aids the sides in the job, and in 6:35 where the centre cut-out would otherwise weaken the sides near the top. In fact, any former which is particularly thin in its cross-grain regions benefits from a doubler strip, which carries the grainwise strength *across* the short grain areas.



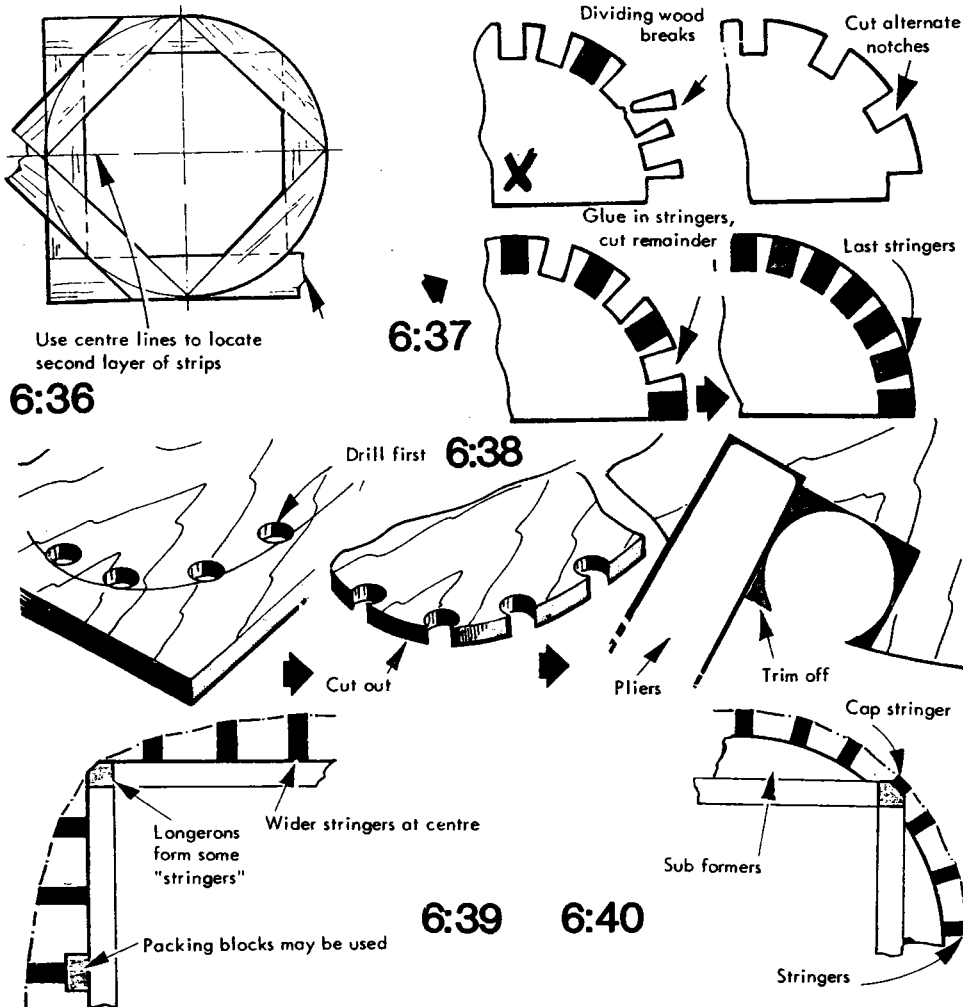

To ensure that the grain really follows the edge of a former, it may be built up from several laminations as in 6:36, which is fine for circular or elliptical cross-section fuselages.

### Fiddly formers

Who has not had the tail end former break up because stringer notches are close together? The answer lies in the details in 6:37 group. The alternate stringers reinforce the former, then when the glue is dry, chop out the remaining notches for the rest of the stringers.

Suppose a former has to be made in plywood . . . what a fiddly job fretting those little notches! Drill holes instead at each notch position, before cutting out the former outline, as in 6:38 group, and tidy it up with a file against old pliers.

### Stringered sides

A box structure can have several strips placed lengthwise to form a curve as in 6:39. The box corners or longerons form four 'stringers' and the rest are graduated in width. A proper stringered finish to a plain box frame needs sub formers as in 6:40 but provided the formers are close

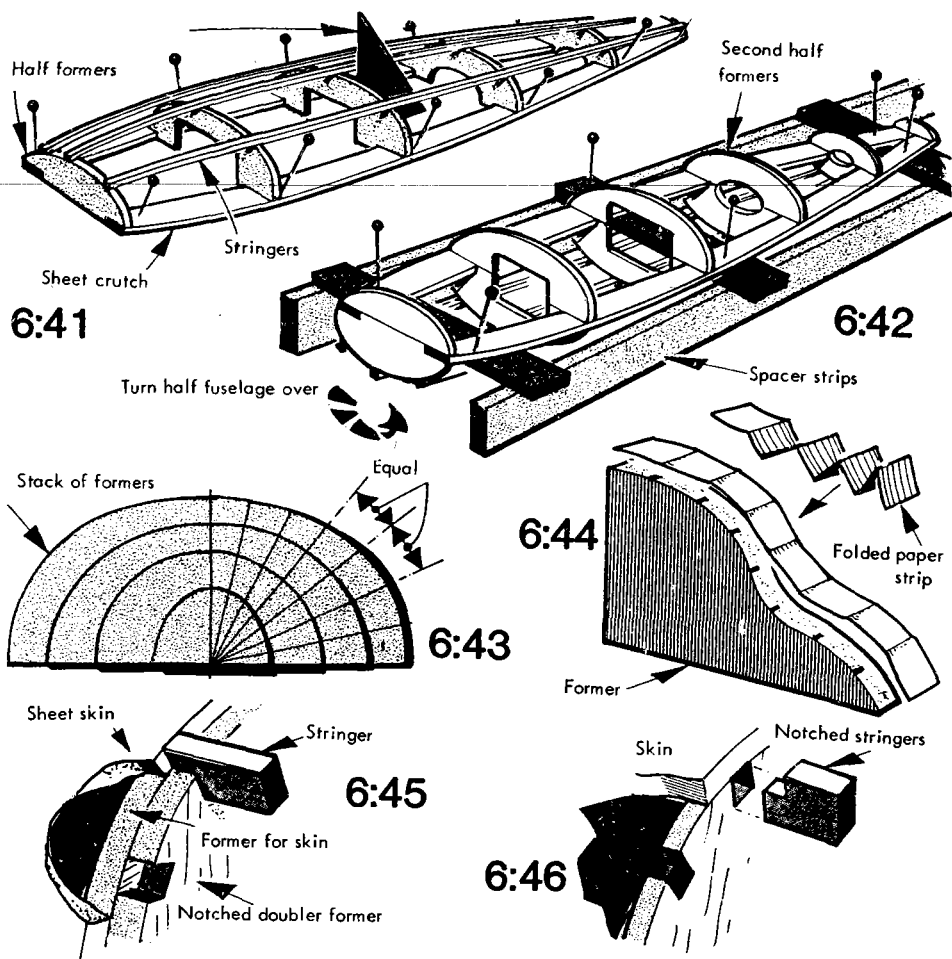

together and good joints are made, they need not all be notched. In any case notches must not be as deep as the stringers, so that the fabric does not touch the former edge.

### All-stringered fuselages

A relatively complex job, this . . . so try making the fuselage in two halves (port and starboard) over a crutch laid on the plan as seen in 6:41. Turn it over when most of the stringers are in place and support this half on packing pieces so that the remaining half formers and stringers can be built on as in 6:42. There may be a tendency for the half fuselage to spring up at the ends, so pin or tape that crutch down well, before the second stage.

### Spacing stringers

In order to get each stringer evenly spaced from its fellows on every former, mark the edge of each former by first laying them over each other as in 6:43 and ruling radiating lines over the stack. If you have forgotten to do this, take a strip of paper and wind it round the offending former, fold it into as many pleats as there are stringers – do it evenly – then stretch it round the former again to mark at each crease (6:44).

## Stringers to sheet

This junction needs a notched sub-former to carry the stringers and a full one for the sheet as in 6:45, or the stringers can be notched for the sheet, but put them in first as on 6:46 or the glue will block the notches.

The stringers may even be notched into the sheet and former if you have the patience (or forgot about it!). A nice detail is the scolloped fillets between stringers where they meet the sheeted area. Often uneven and ill-fitting when done in an unplanned way, these fiddly shaped pieces can be formed in pairs by punching holes with an X-Acto punch or piece of sharpened metal tube. Sketch 6:48 shows how and 6:49 where.

## Planking

The mysteries of planking reveal themselves as you work – it is mainly practice, although there are several basic rules. Rule 1 is to have the formers close enough together to support the planks, thus avoiding a 'starved horse' appearance – say 3½-4in. max. Rule 2 is to shape the planks for perfect results. Sketch 6:50 helps here. Treat those formers like sketch 6:43, but in this case the widths are transferred to the

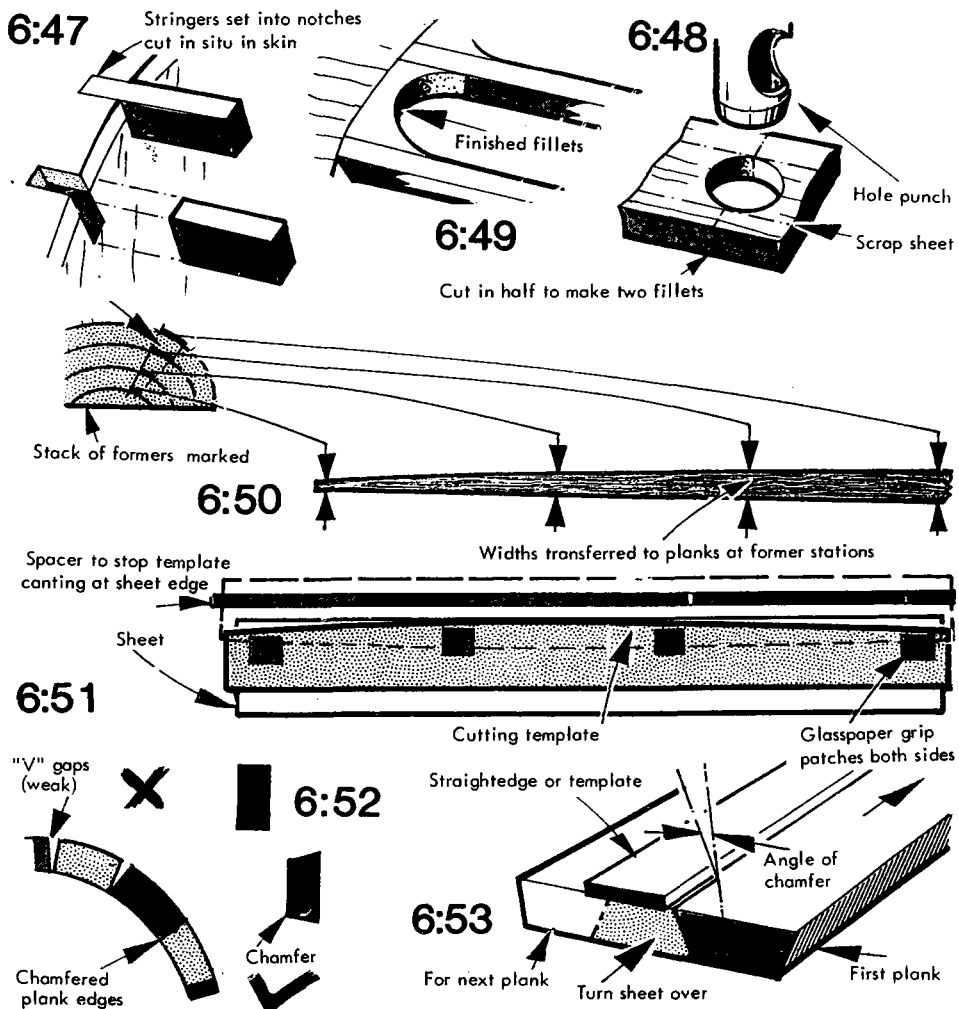

stringer strip. From this information a ply cutting guide can be made and used as in 6:51. Note that spacing piece of balsa to prevent the guide tilting as the edge of the sheet is approached.

Thick planks on small radius leave ugly 'V' joints and offer poor edge-to-edge gluing area. In this case, it would help if the planks were chamfered, as compared in 6:52. The planks may be cut by using the cutting guide (or steel rule) and knife but angle the blade as in 6:53.

Parallel planks may also be used and if they need to be chamfered, a balsa stripper can be used as in 6:54; just prop up the sheet from which the planks are to be cut and allow the stripper to cant over onto the cutting board. Turn the sheet over to get the taper in the correct relation to the one just cut. (6:55)

How do the parallel planks fit? Sketch 6:56 shows this 'lazy planking' system. Groups of planks are laid edge-to-edge and naturally enough touch at the ends but not at the middle. By following the order shown cut-down planks gradually fill these gaps.

In order to mark the shape to be followed when trimming those later planks, try the method in 6:57. For it to work effectively, the untrimmed edge of the new plank should be parallel to the adjacent fitted plank, then when the opposite edge is trimmed, it should fit. Try cutting overlength until practised in this method.

Use sandable glue – some woodworking P.V.A. type glues go rubbery when sanded. This ruins the effect of planking or indeed any

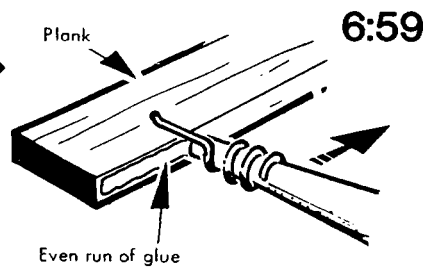
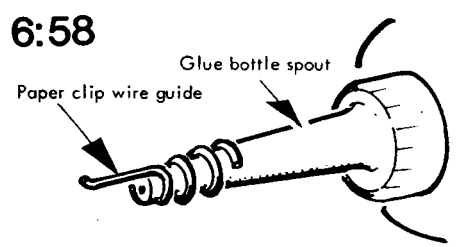
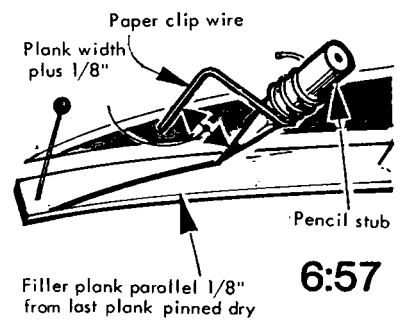
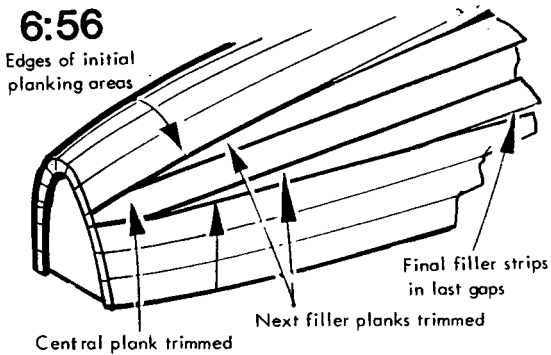
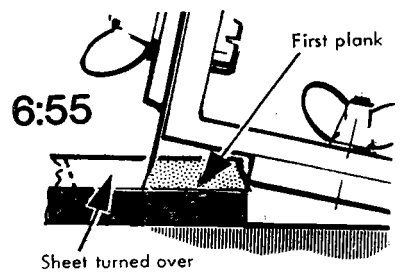
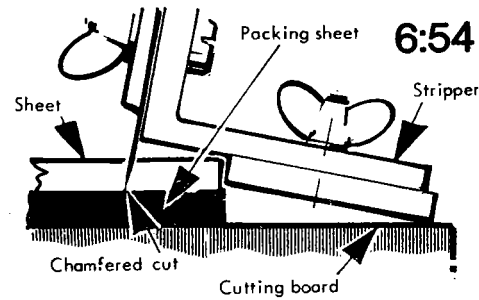

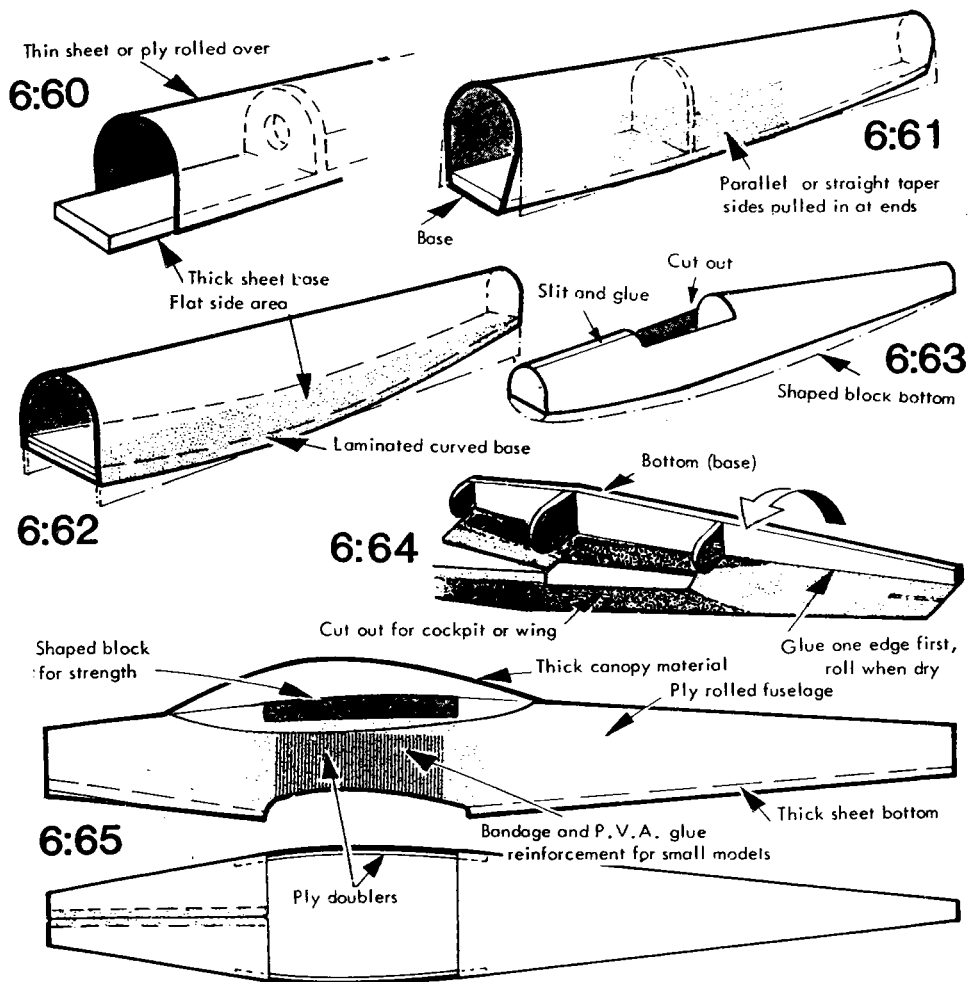

surface joint. To get just the right amount of glue right on the very edge of the plank can be rather tiresome, so try the gadget in sketch 6:58, which guides the spout of the glue bottle as seen in 6:59.

### Rolled fuselages

Effective fuselages or tail-booms may be formed by bending thin balsa sheet or thin plywood over formers to make a tube-like structure when glued to a flat sheet bottom. Detail 6:60 shows it in a simple form, and 6:61 indicates that the bottom may be shaped to give a curved bottom planform to the sides. The top has to be straight, of course, but that bottom can curve upwards as well when laminated as in 6:62. Trim off the surplus side parts when the glue is set.

### Changing the top

Imagine a fuselage with a lowered decking forward of the wing . . . Easy; sketch 6:63 shows how a lengthwise slit is made at the front and the edges overlapped to lower the line. Cut formers to fit afterwards.

The method of rolling that ply is seen in 6:64, but remember to allow about  $\frac{1}{4}$ in. overlap at the bottom edge and allow one edge to dry before rolling.  $\frac{1}{32}$ in. ply is quite thick enough; use  $\frac{1}{64}$ in. ply for small models.

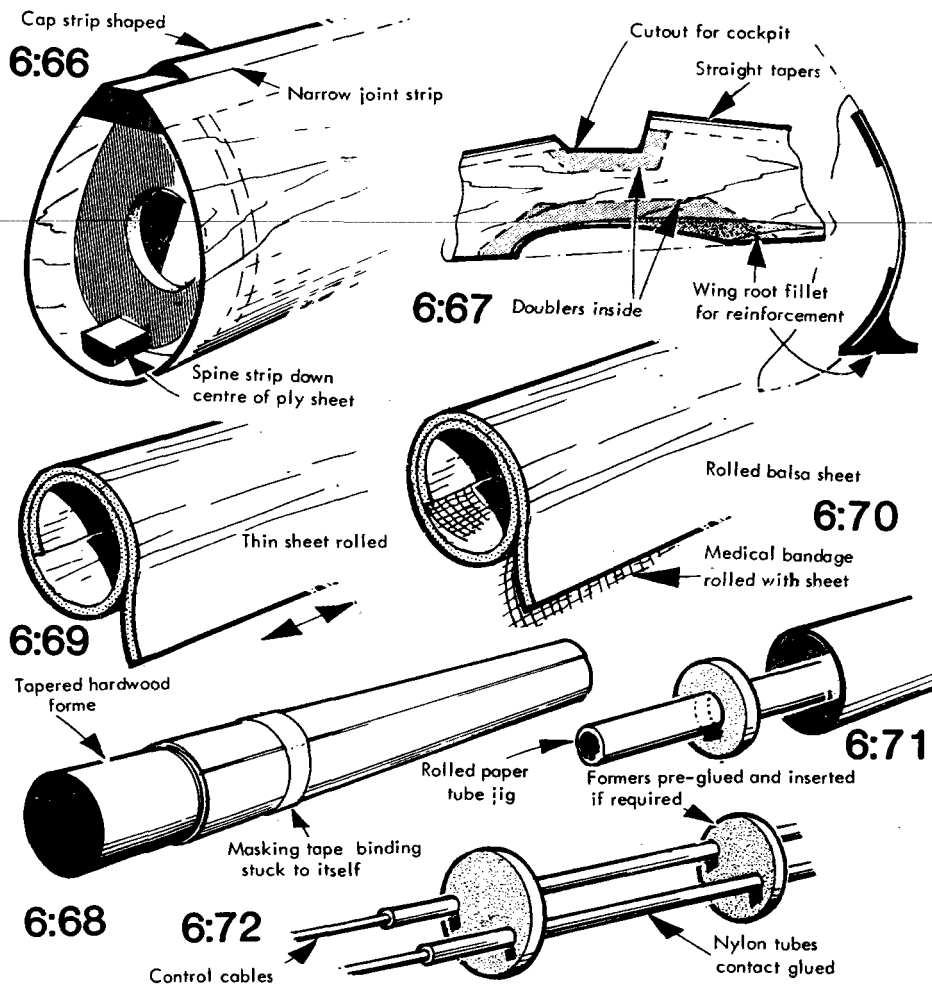

### Keeping the strength up

A dual curvature in the fuselage is not possible, but the nearest thing to it will be seen in 6:65. Do not neglect to reinforce the area near the wing and cockpit, where the section changes and loses some rigidity.

A variation on the rolled ply fuselage theme can be seen in 6:66. Here, the bottom is rounded and the top edges clamped together over a narrow strip. It makes a much thinner fuselage and lends itself well to the up-to-date hump-back profile. It too can be tapered fore and aft as in 6:67, but additional part-rolled doubler pieces of ply are vital where a cut-out is made in the curved bottom area, say for the wing. External fillets will also stiffen the edge of the hole.

Thin straight grained balsa sheet can be rolled over a well-waxed tapered forme (such as an old billiard cue). If the sheet has to be damped to aid bending, as seen in sketch 6:68, watch it while it dries, and gradually slide it off as it shrinks back to size, or it may bind on or split. Several layers of thin sheet are better than one thick layer, as in 6:69. Tissue or bandage may be laminated in (6:70) to resist splitting for little weight penalty.

If formers are to be inserted to reinforce the tube at stress points, use a small-bore core tube as a permanent jig as in 6:71 or utilise control cable tubes as in 6:72.

# CHAPTER 7

## Around the engine

**Cowlings**  
**Slot-props**  
**Ducted fans**  
**Silencing**

See also Chapter 6

Cowlings, if little else, may need the hollowing of laminated balsa blocks in their construction. Sketch 7:1 shows how pieces, fretsawn from larger laminations, can be used up for the smallest ones. It also indicates the preferred direction of carving, once the laminations are glued up.

Such a technique might be used for a fixed lower cowl, which supports the bearers, as seen in 7:2. The upper part is removed to gain

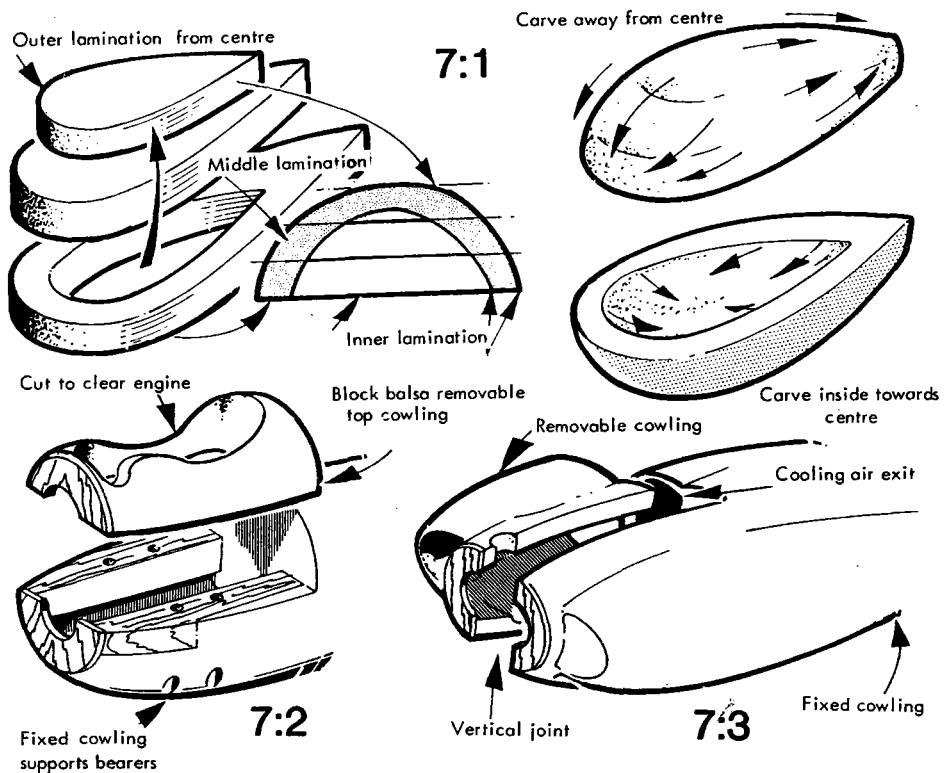

access to the engine, which in this case would be upright. If the engine is side mounted, cheek cowlings may be made, either from solid block, or from block at the front and curved sheet aft (7:3).

Up, down, or sideways, the radial cowl has no restriction on the engine. A front ring from 4 or more strips of balsa can be made up on a ply ring and sanded to section as in 7:4. The sides are rolled ply (disguise the joint below), with a further ring at the rear, or alloy brackets to mount it. Sketch 7:5 shows a composite cowl for an inverted (or upright) engine. This type would do for control line models, but could be modified for sport or radio control machines. Those single curvature sides can be  $\frac{1}{32}$ in. ply.

7:6 shows how to blend a square fuselage into a spinner, by adding thick doublers and triangular strip. Note that the rear ends of these added pieces are tapered off to make room for the engine and its bearers or mount. A hole would be cut to clear the cylinder and it could be slit lengthwise for access. Always face the meeting edges of such components with  $\frac{1}{32}$ in. or  $\frac{1}{64}$ in. ply, because there is much vibration to cause wear and consequent fuel seepage. 7:7 shows the construction for an all-balsa version of that in 7:5.

7:4

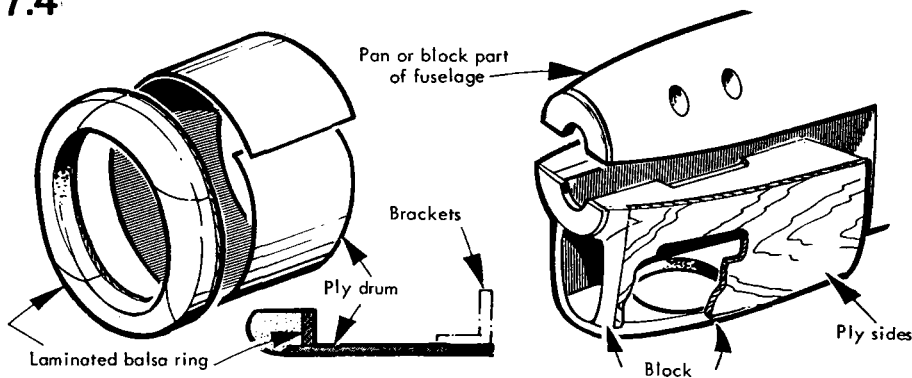

7:5

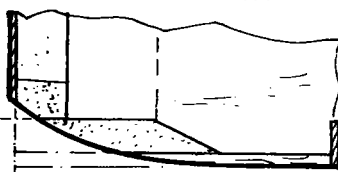

7:6

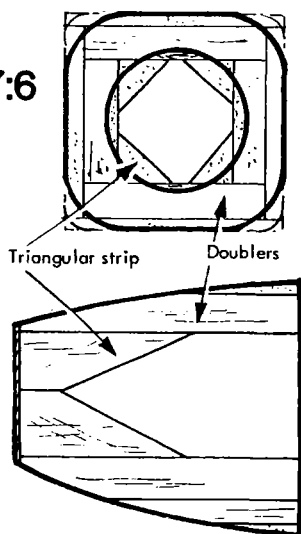

7:7

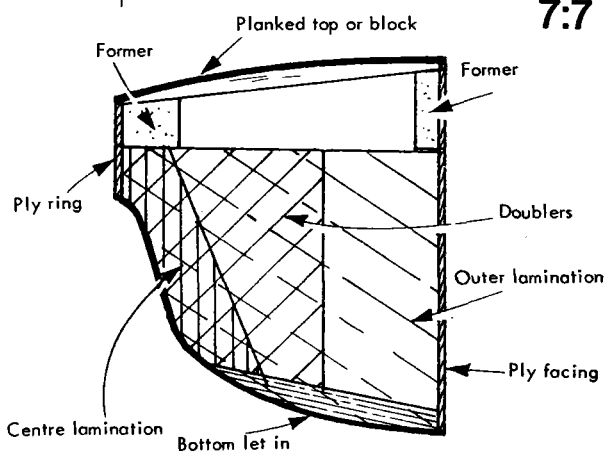



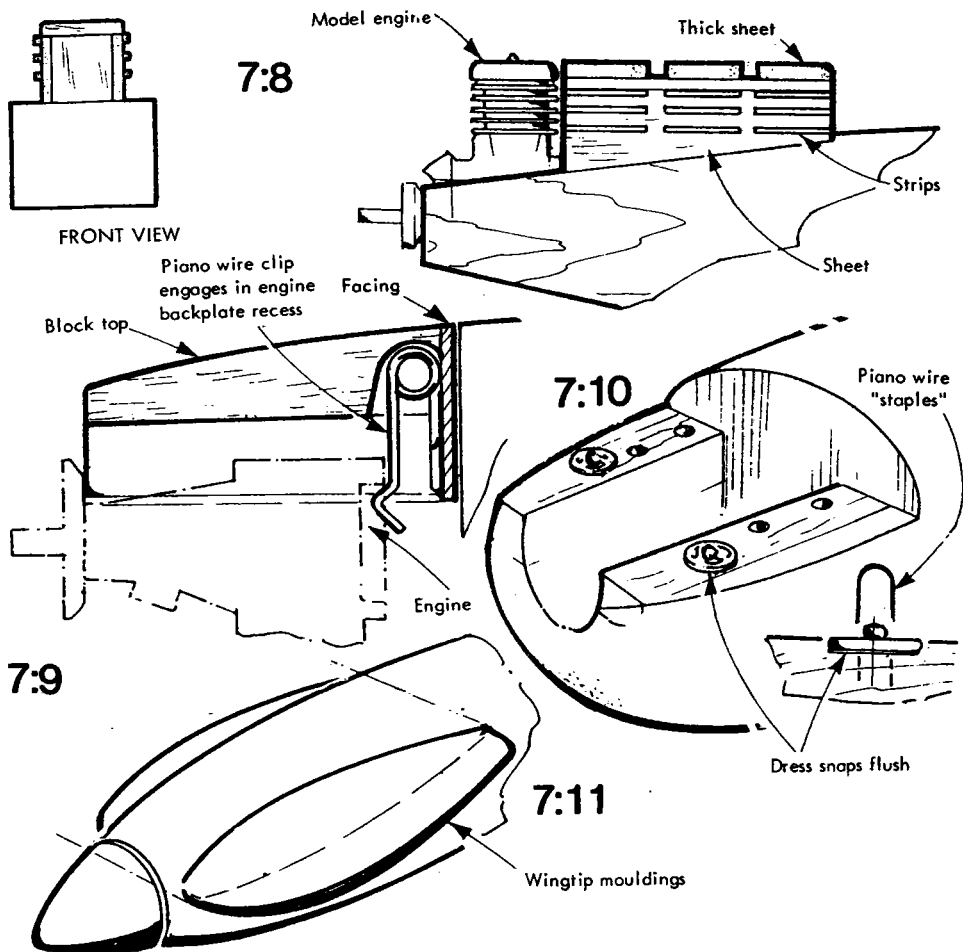

When a cylinder of a model engine projects from the cowling or fuselage it may be an eyesore in an otherwise streamlined form. What, however, should be done with the cylinder in sport models of free-lance design? Sketch 7:8 shows one idea employed in a pseudo World War I machine. Most of the engine is expressed as part of a dummy exposed one. A box-like (sheet) 'three cylinder' block follows on behind it. If required, the back and front ends can be left open to allow for extra engine cooling. One of the author's models employed beer bottle caps as dummy cylinder heads.

### Keeping it in place

The removable parts of a cowling should be easily clipped in place, in some cases, while the engine is running, although it is a better policy to arrange adequate access to the engine via holes. A wire clip on the cowling can engage in the engine backplate recess as in 7:9, or dress snaps can be set in flush as in 7:10. To align the snaps, fix the male half first, then press the cowl down to leave an imprint of the pip, to locate the centre of the other half. Ply facings will not dent easily, so put a smear of Plasticene on the surface.

How about utilising ready-moulded parts for cowlings? Sketch 7:11 shows vacuum formed wingtip mouldings trimmed and prised open.

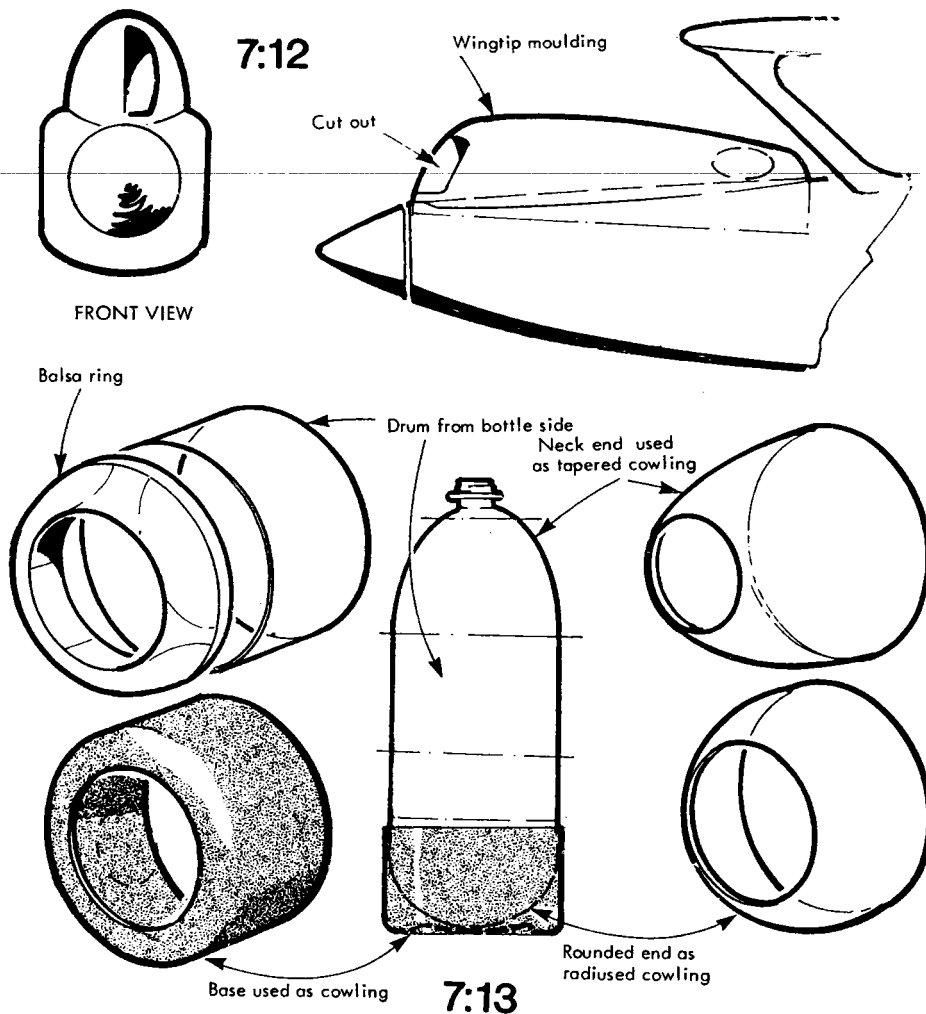

The unoccupied cowl half can be plain, but that which houses the cylinder needs to be cut for cooling, as in 7:12, which illustrates a helmet type and would also serve an inverted engine. Keep the plastic well clear of the engine to avoid heat softening it. Commercial bubble cockpit canopies can also be used as the rear part of helmet or side cowls, with the 'hot spot' taken care of by balsa block. Fizzy drink bottles yield several useful areas for turning into radial cowlings, as seen in 7:13. The base, which can be carefully detached and cut out in the centre, makes a small-radius front type. The bottom of the bottle itself is hemispherical and can be used for those more rounded nose sections. The cut-away tip might even be incorporated as a spinner on smaller models.

The neck tapers and provides a more streamlined version. What is left can be cut to length to form a tubular section aft of a balsa/ply nose section. The smooth plastic surface aids a good finish and extra strength can be achieved by lining the tube with balsa or thin ply with the major grain direction fore and aft. Many more ideas may present themselves in a search through the kitchen store of tubs, jars and lids.

## Slot props

While dealing with that which encloses the engine, mention must be made of the 'slot prop' system, where the airscrew is situated way back down the fuselage. Although the model prototypes were flying as early as the 1950s, only recently has the full-size aircraft world adopted them. Sketch 7:14 explains what happens. The major requirements are as follows: 1) Circular fuselage cross section at the prop position, if the prop is to be in the main fuselage area. 2) A good wingspan if the prop cuts through it. 3) Some convenient means of separating the fore and aft sections of the model, for starting or servicing the engine, and 4) spring start engines, belt and pulley starting (as in ducted fans) and access hatches. *Prop Secret*, the prototype shown, uses a rolled card fuselage about 4in. dia and a 1.8cc diesel driving a 9in. dia. prop. The sketch shows bearers, for the benefit of the large number of modellers who have beam mount motors – see 7:15. Dowels join the removable outer wing panels and fuselage nose, but vertical metal tongues could be used. The prop has a balsa and ply drum slipped over it (7:16) and the plan view in 7:17 shows a typical layout. Remember that in this

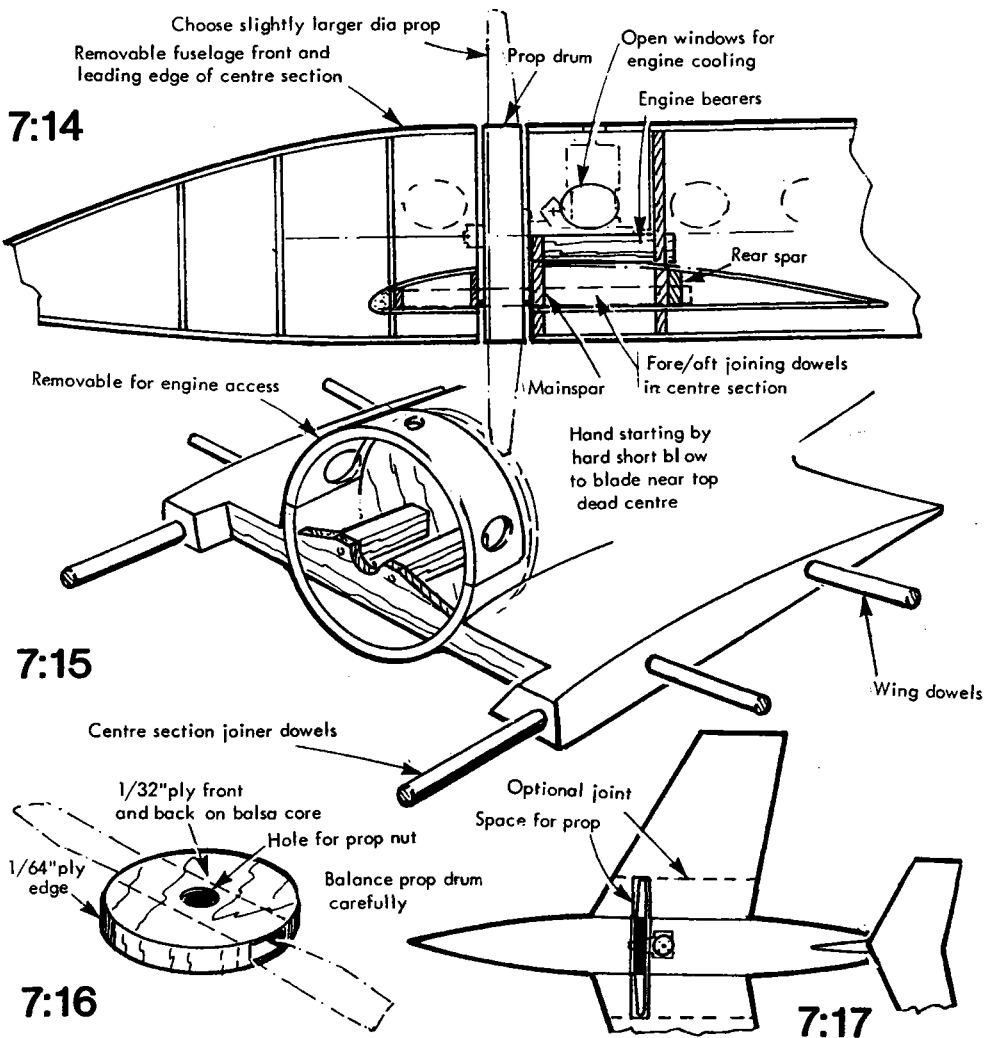

case, it is the wings that hold the fuselage together. However, in the pusher layout shown in sketch 7:18, the wing is clear of the prop and the fuselage is deep enough to be joined to its tail section. It is, in fact, a filled-in twin boom, arranged vertically. If the engine can be started without removing the rear part, then radio control can be installed, with cables to elevator and rudder running around the edges. It is not outside the bounds of possibility to arrange that both cables go outside *one* joint and allow hingeing of the fuselage by their flexibility. Another method is to house two servos in the rear section and lead the wiring across the joint, to sockets in the front part.

Taking the engine further back gives the opportunity of installing it in a slotted fin, perhaps less obtrusively than in a conventional pusher layout. The tailplane can carry the rudder linkage to a forked horn to engage in the rear part of the fin or the top of the rudder itself. Sketch 7:19 shows the general arrangement, with the engine in a thickened-out part of the fin. The side-on view of the prop appears to fill-in the slot, so the system is not as obtrusive as might be imagined.

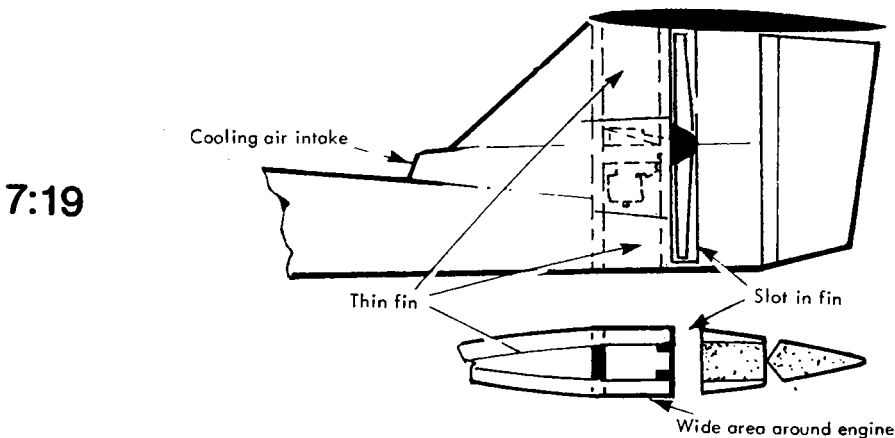
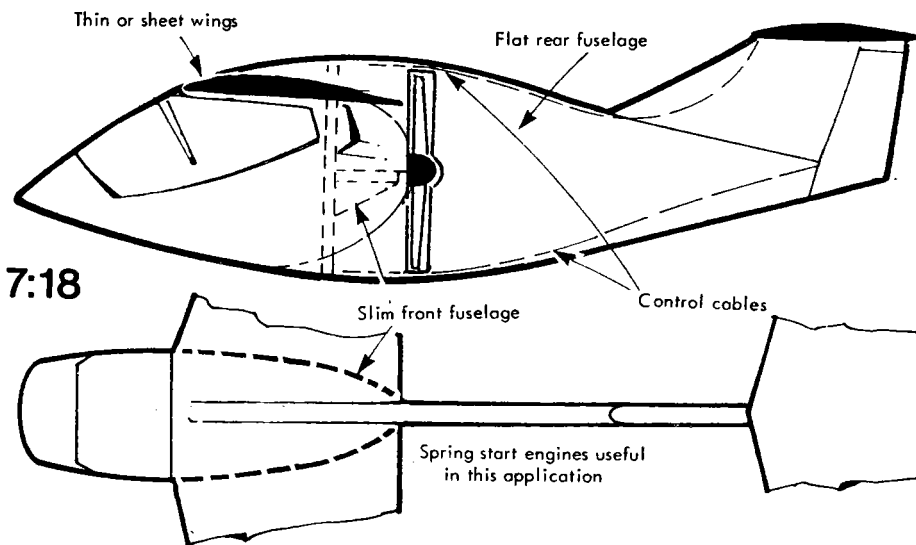

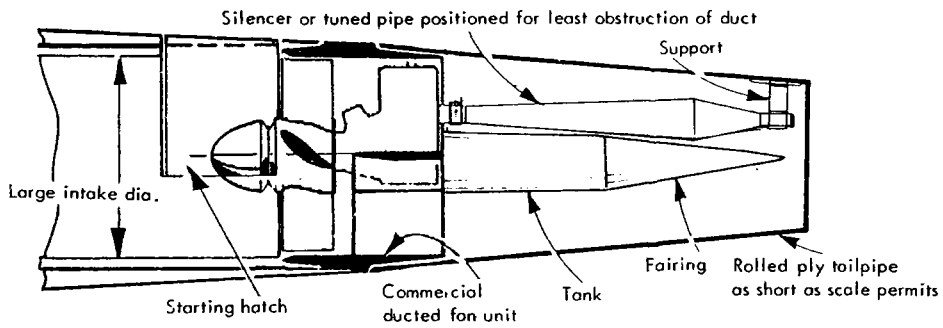

7:20

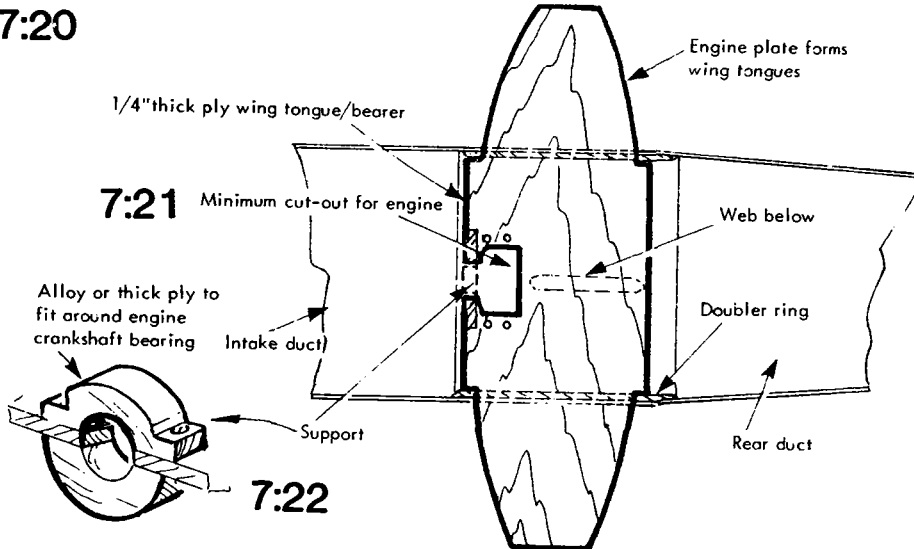

7:21

7:22

## Ducted Fans

This system requires high revving engines. Most ducted fan models today are radio controlled and need high power, so there are several commercial ducted fan units, comprising a motor mount and short tube which surrounds the fan and engine. It is this unit that has to be blended into the arrangement of ply tubes which form the tailpipe and intake ducting. All other structure should be outside the duct to permit unimpeded airflow. However, as will be seen from 7:20, the tank and tuned pipe silencer need supports, so a reinforcing patch has to be added to the tailpipe. Similarly, spacing webs can support the tank fairing and act as flow straighteners.

In home-brew engine installations, the wing mounting tongues can form the mount, but it is often necessary to add a web close to the engine to damp out vibration and strengthen the duct by reinforcing with a 'doubler ring' which is rolled from plywood. A strengthener can be screwed to the front of the engine mount as in 7:22 and this can be tailored to fit the engine crankshaft bearing housing, thus relieving the strain of starting from the lugs themselves. Naturally, the size of this alloy or hardwood block should be less than that of the fan hub. It is essential to fuel-proof the inside of the duct, which in some cases becomes a main structural element. Free-lance models can have the radio linkages running down a dorsal or underbelly fairing, having the tailpipe as the rear fuselage alone.

## Silencing

Engine noise is a very sensitive part of public relations in the radio control world. It is not only the exhaust noise that annoys, but the rest of the model vibrating in sympathy – see 7:23.

The engine itself produces mechanical sound by transmitting its movement to the airframe; the covering drums and amplifies the sound. The silencer radiates sound waves by vibrating; thin home-made silencer tubes are suspect here, 'panting' with the exhaust pulsations. Sound also comes from the carburettor (remember your car system). Let's see how some of these sounds can be reduced . . . If the engine is resiliently mounted as in 7:24 the vibration is reduced by the time it reaches the airframe. It is important, however, to have a long bearing surface between engine mount and engine bearers, otherwise the engine will rock and probably vibrate more. Experiment is needed to find the correct hardness of rubber packing. Whatever the method chosen, be sure to avoid any direct rigid contact between the engine mount and the bearers, or as in 7:25, the engine mount and bulkhead.

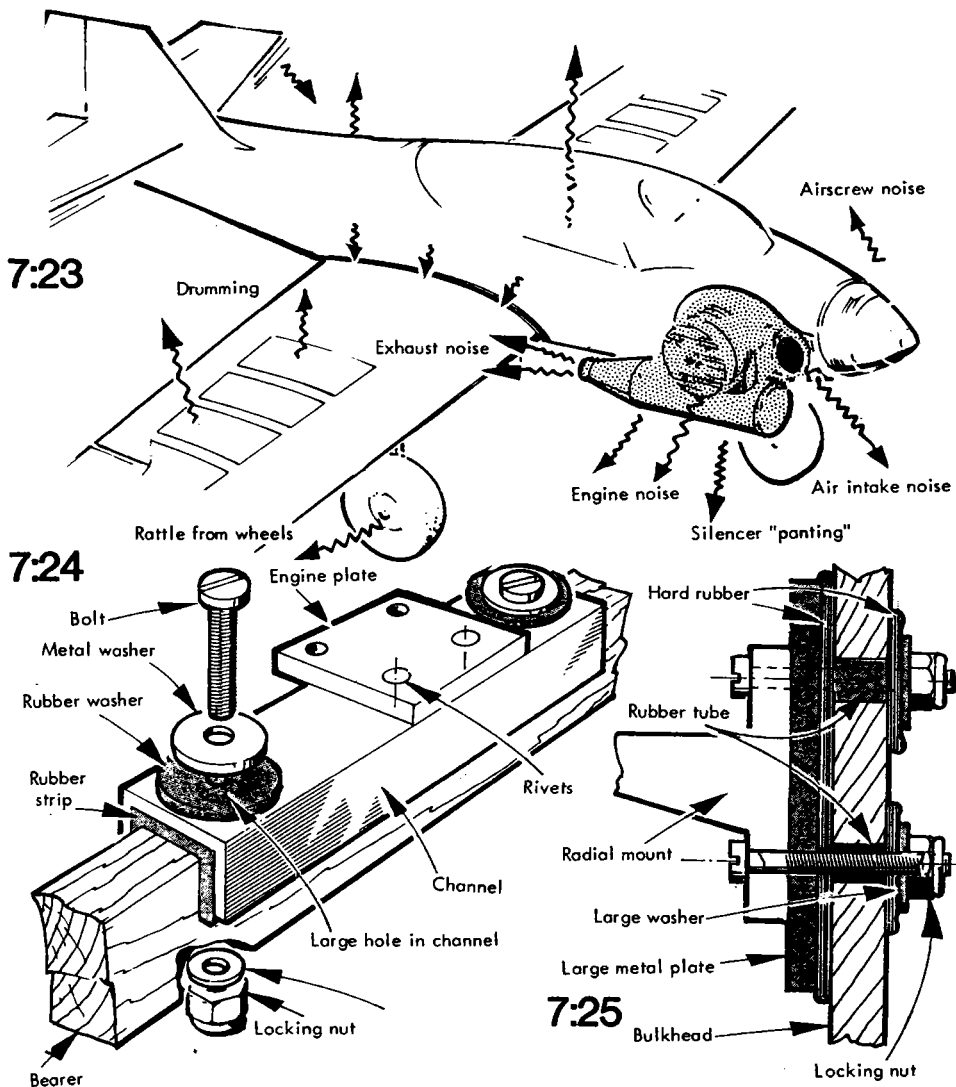

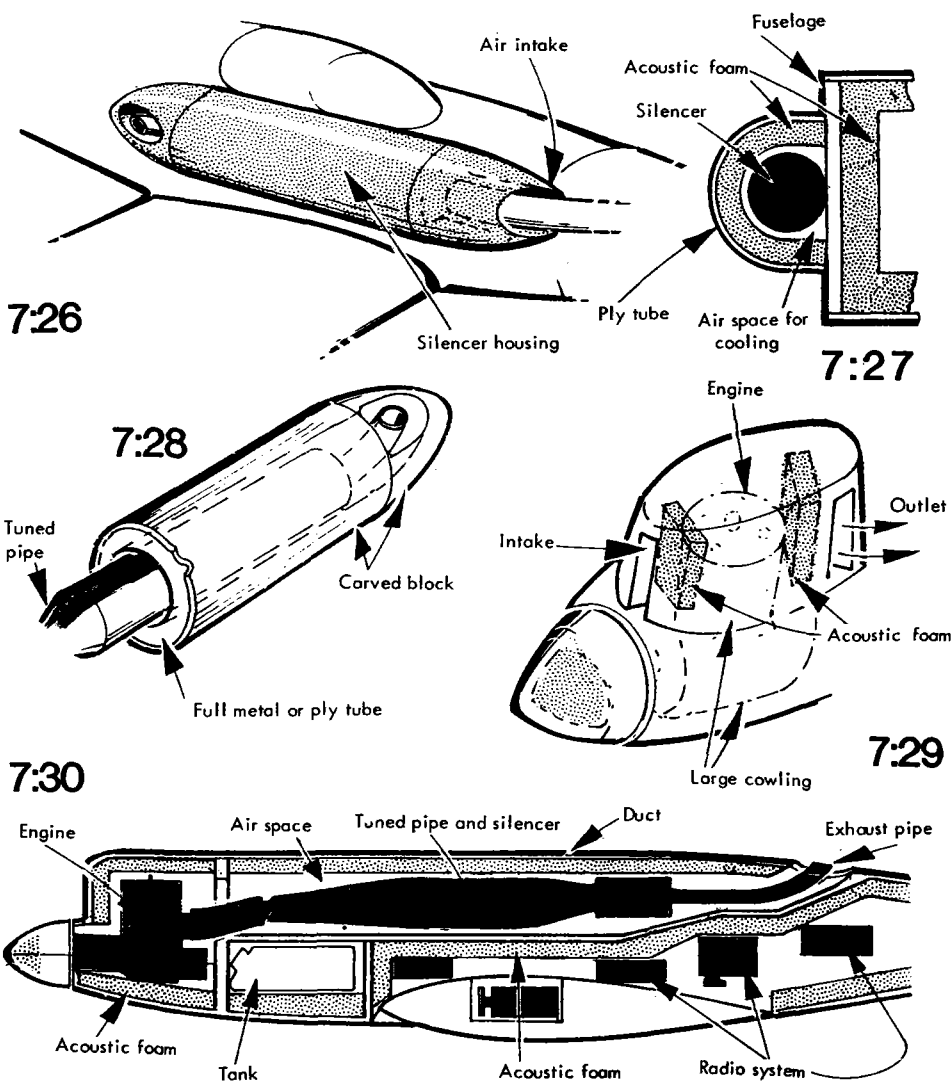

It is the shape of the mounting rather than the bolts that keep it in alignment so by *gluing* the rubber lamination in place in addition to the bolts, the mount should not allow the bolts to transmit vibration to the bearer or former.

Efficient silencers can be quite large, but even so, an improvement should be noticed when such a silencer is enclosed within a fairing as in 7:26.

The ends have to be slightly open to allow cooling air to pass around the silencer. Some airborne sound radiating from the silencer sides can be absorbed by a thin ( $\frac{1}{4}$ in.) layer of fairly dense sponge foam plastic. This will melt and give off toxic fumes if allowed to touch the hot silencer; beware! Aim to interrupt the direct 'line of sight' between the noise-producing parts and the outside world. The separate housing in 7:28 only goes part of the way.

Cowlings are the most difficult to treat, but with space inside the intake and exit slits can be screened (not blocked) with foam (7:29).

The 'full treatment' is seen in sketch 7:30.

# CHAPTER 8

## Hatches, cockpits

Reinforcing cut-outs  
Glazing  
Canopies

See also Chapter 6

Large holes in the surface of a fuselage can be a source of potential weakness, for example, an access hatch near the nose reduces the strength across the fuselage. If this is on top, as in 8:1, an upwards landing shock at the nose will cause the sides to open out. This is explained in sketch 8:2, so a safer position for the hatch would be on the underside as in 8:3, but in any case cross struts at the ends of the opening need to be well fixed to the sides.

Any opening which chops through load-bearing skin or longerons needs to have a doubler as in 8:4. Note how the ends of the doubler are chamfered to spread the load gently.

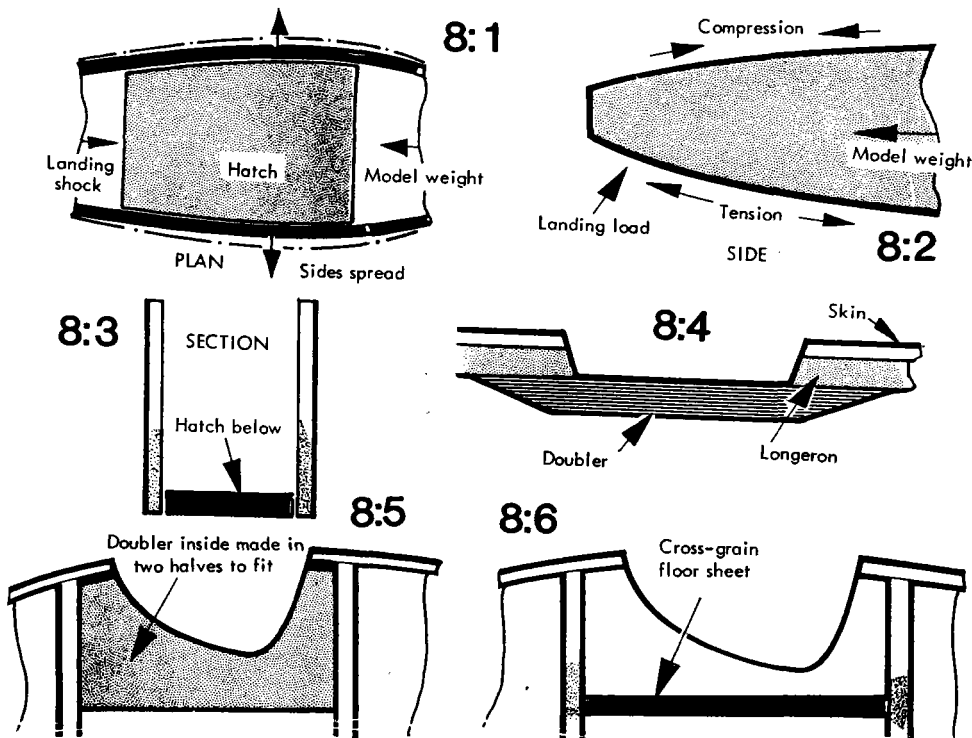



Cockpit openings can be given a second skin inside to act as doublers (8:5) and wherever possible a high level 'floor' as in 8:6; the grain runs across the fuselage to provide a tensile brace.

Hatches in flat or slightly curved sheet skins can be started by carefully making four holes with a hole punch rotated gently, saving the waste retrieved from the punch as in 8:7. Cut the outer edge with a knife, then glue the waste into the hatch panel at 45° to offer end grain to the edge.

To stop the panel dropping in, doublers are positioned to overlap the edge as in 8:8. Where hatches occur on curved top decking or in block areas, the edges can be faced with thin plywood for strength and neatness (8:9). Hatches are best located between formers and if of rolled sheet or planked, have end formers too as in 8:10. The skin is applied all over, then the hatch cut free, hence the spacers to allow for the saw blade. 8:11 suggests a means of making straight horizontal final cuts to free the hatch after cutting through skin and spacer scrap.

Ply can then be inserted and marked for trimming as in 8:12. When gluing these in, polythene between fuselage facing and hatch facing

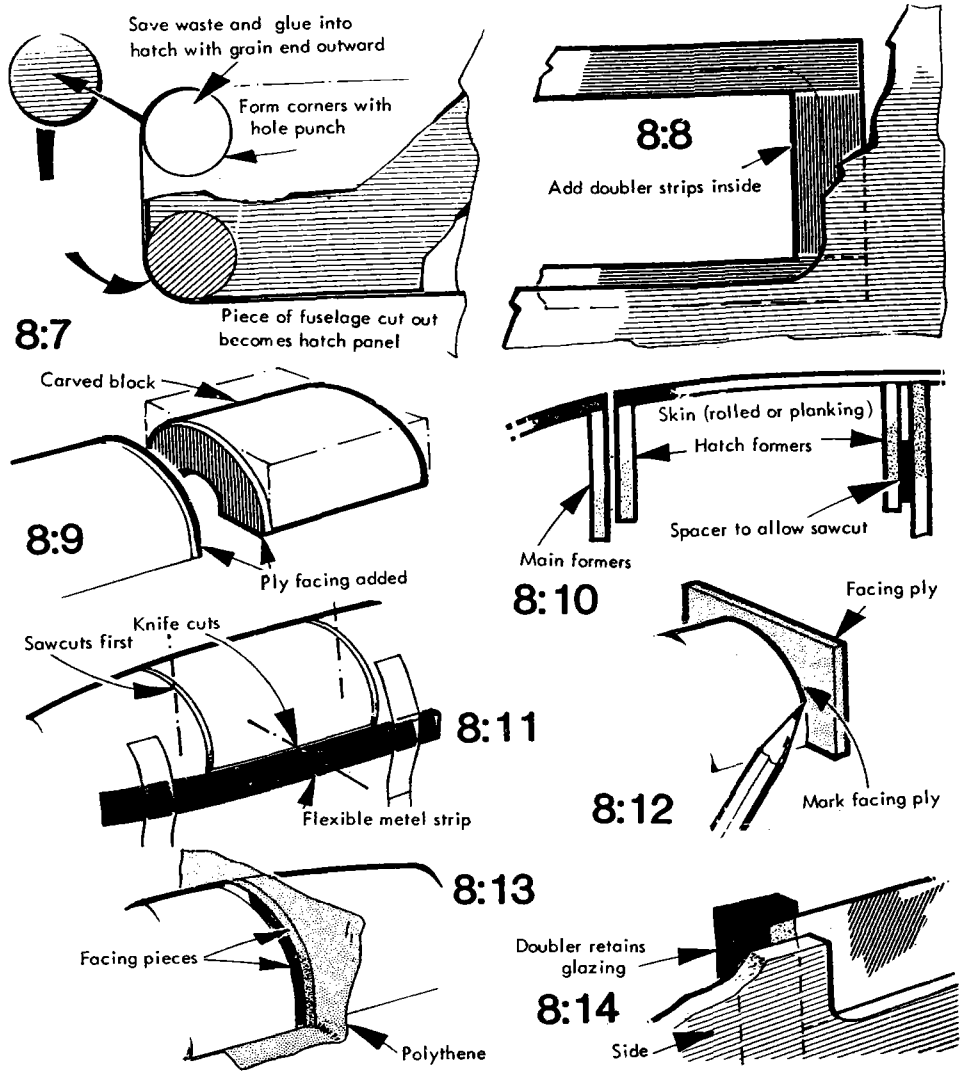

prevents accidental gluing in of the hatch (8:13).

Now let's put some glazing in . . . Suppose the cut-out is in the form of a cabin window, as in 8:14, then the acetate glazing can be held in place by the doublers themselves, but these are set back slightly from the edge for neatness.

This detail can be modified to suit open frame fuselages with infill panels as in 8:15; allowance has been made for a thin plywood frame to give strength and neatness to the opening. If weight saving is a prime concern, balsa strips mitred at the corners will serve as in 8:16.

## Windshields

The most simple form of windshield is a curved piece of acetate or clear ABS cut from a flat sheet to a paper pattern. Leave two or three lugs to slip into slits in the fuselage for security as in 8:17. An edging can be applied in the form of split plastic or rubber tube. A better trim is a thin ply or aluminium litho plate frame carefully fretted out (temporarily fix the plate to plywood for a clean cut). Apply the frames to a folded flat sheet of ABS and trim to shape (8:18).

A short cut is to take the front of a commercial bubble canopy and paint on or apply paper frames as in 8:19. Why not use the rest of the

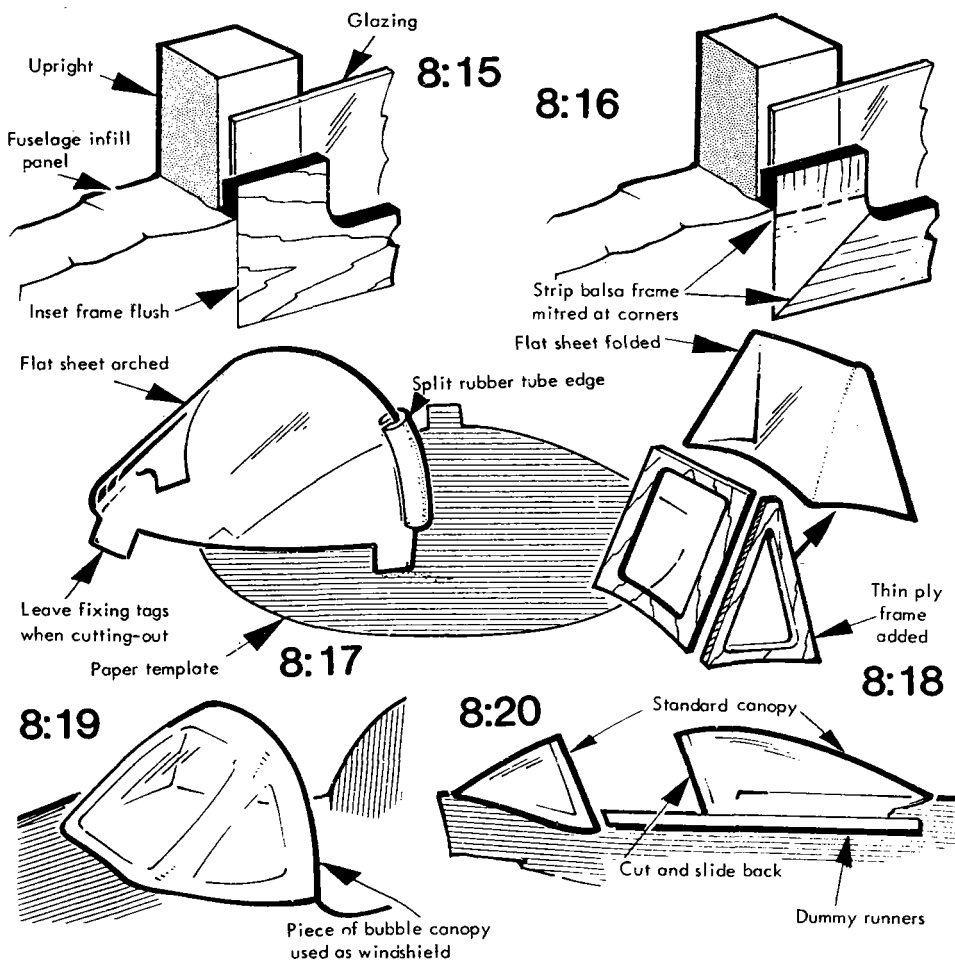

canopy to represent a slid back canopy, on those models which have canopies rather than 'open-cockpit-and-windshield' just described? With cockpit detail and dummy canopy rails, this is quite convincing and a welcome change from the plain bubble type.

### Commercial canopies

There is a wide range of ready-moulded canopies, so the average model has no excuse to be unadorned. However, it is provident to have a few canopies around when designing a new model so that a suitably shaped top decking can be arrived at.

Suppose the new creation demands a different treatment. A more rakish angle can be adopted by trimming a larger canopy at the back as in 8:21. The sides can be pinched in as in 8:22, or the sides of a narrow canopy spread to make it arch as in 8:23. Windscreens of cabin models can be made more bulbous by taking two pieces from the sides of a large bubble canopy and turning them around to fit on a central frame (8:24). The bubble type can also be cut into three sections and condensed in length or modified with bent flat sheet, angled by making 'V' cuts and mounted on frames, all as per 8:25.

Really racy windscreens can be made by turning a bubble canopy around and cutting it to fit, see sketch 8:26.

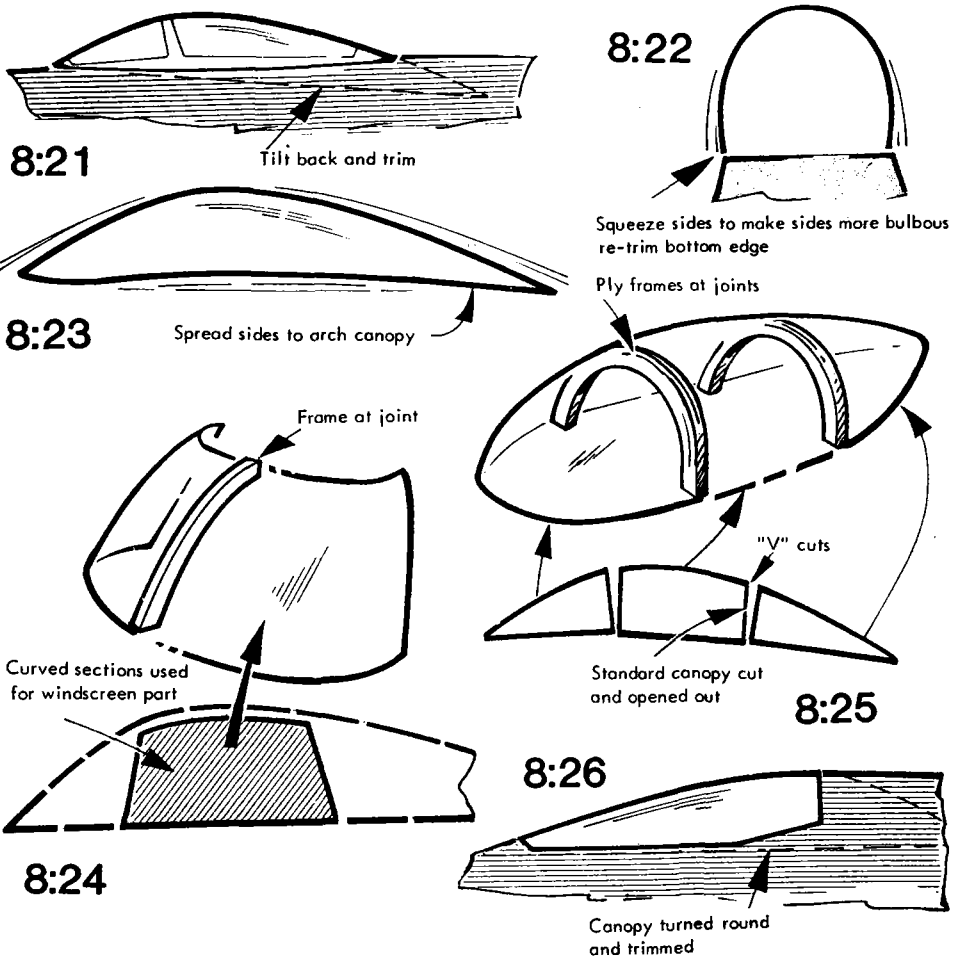

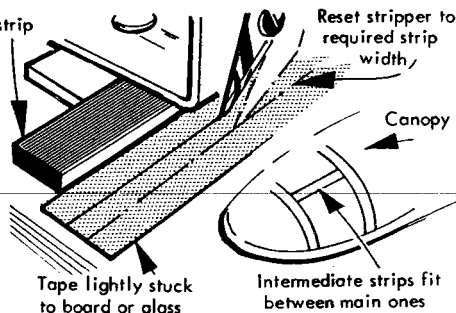
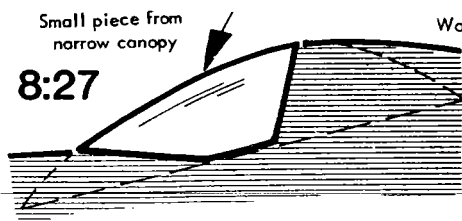

8:28

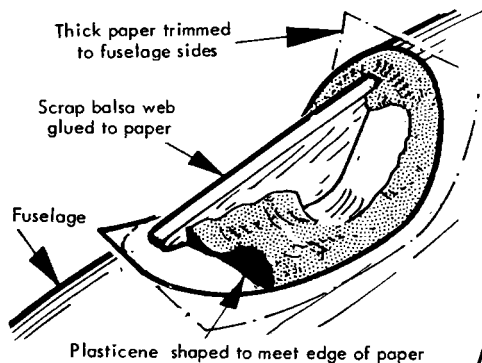

8:29

Leave just enough exposed for adhesive

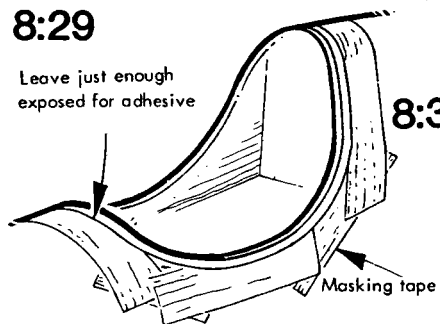

8:31

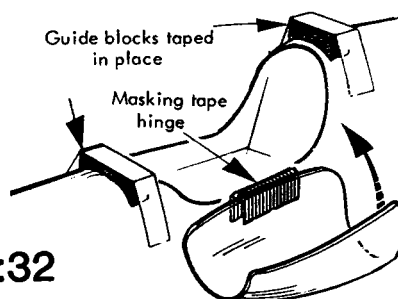

8:32

Almost any screen shape can be derived from canopies by trimming one or both ends as 8:27 shows. Dummy frames can be simulated by cutting strips of self adhesive vinyl or masking tape with the aid of a balsa stripper (8:28). Varnish over with fuel proofer to secure.

### Fitting the canopy

It is all too easy to mis-trim the edge of the canopy, but the method in 8:29 aids the marking of the cockpit edge on the canopy moulding. Be sure to avoid bending the Plasticene used, during its transfer into the untrimmed canopy as in 8:30.

Now the canopy fits, it can be fixed with epoxy or contact glue to the almost finished fuselage. Masking tape will ensure that there are no unsightly blobs outside the edge – see 8:31 – and some guide blocks and a masking tape hinge can help the pre-glued canopy safely into place without smearing the adhesive around the inside surface of the canopy – see 8:32.

Remember to finish all the detail and paintwork in the cockpit interior before enclosing it. Check it for dust too; the canopy generally attracts balsa dust inside due to static charges.

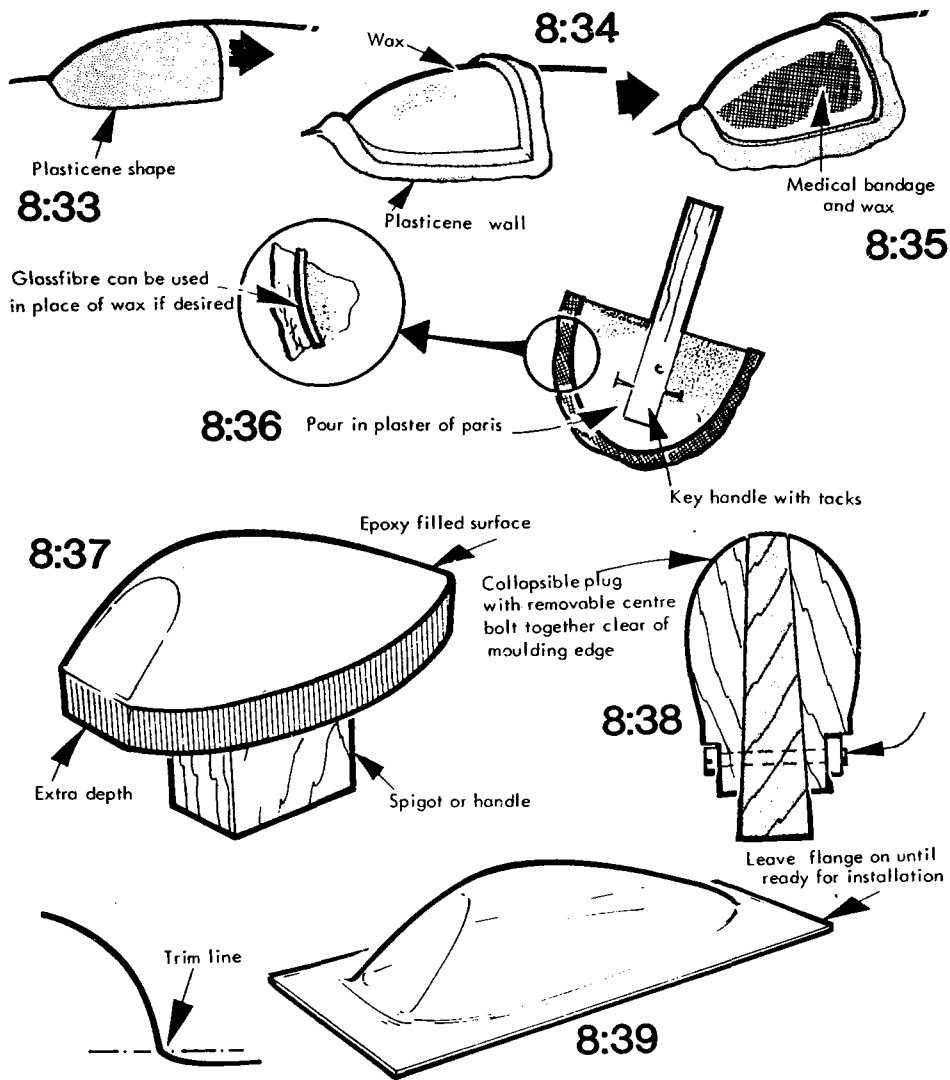

### Making bubble canopies

If you are determined to make your own canopies, or indeed any other formed plastic sheet items like fairings, wingtips, cowlings and blisters, the following few notes may help.

A suitably shaped item called a 'plug' is forced into a heat-softened sheet of moulding quality clear ABS or acetate. The plastic retains the shape on cooling. To make a plug in situ, on the model, study sketch 8:33. Mould Plasticene to the required shape and smooth it flush at the edges. Add a Plasticene bead or wall as in 8:34, which is to contain the mould material which is melted candle wax brushed on. Add more wax and scraps of bandage to reinforce it, as in 8:35. When hard, the mould can be taken off and the Plasticene taken out (glassfibre may be used instead of wax). Cast the plug in plaster of paris as shown in 8:36.

A plug needs to be a little deeper than the finished moulding, so the edge can be built up with balsa or more plaster and trimmed flush, as in 8:37.

Bulbous plugs cannot be withdrawn from mould or moulding unless they have a wedge down the centre like that seen in 8:38. If the extra depth is shallow, the canopy may not trim properly (8:39).

Simple mouldings (without undercuts) can be made by pushing the plug into a hole in a ply plate so that it draws the plastic sheet down into the hole. 8:40 explains. In this example the hole in the ply, which should be about 1/4in. thick, clears the plug by the thickness of the plastic sheet all round. The plastic should be pinned or clipped in place before heating in the domestic oven until really soft, but not so hot that it blisters. Wear thick gloves and quickly plunge the plug in. An additional plate can be made to clamp the plastic sheet as seen in 8:41. This allows the free movement needed to make an even moulding.

### Vacuum forming

A professional moulding machine is not cheap, but thanks to the use of a domestic vacuum cleaner and oven or electric fire, both in unmodified form, moulding can be done with the simple box unit shown in sketch 8:42.

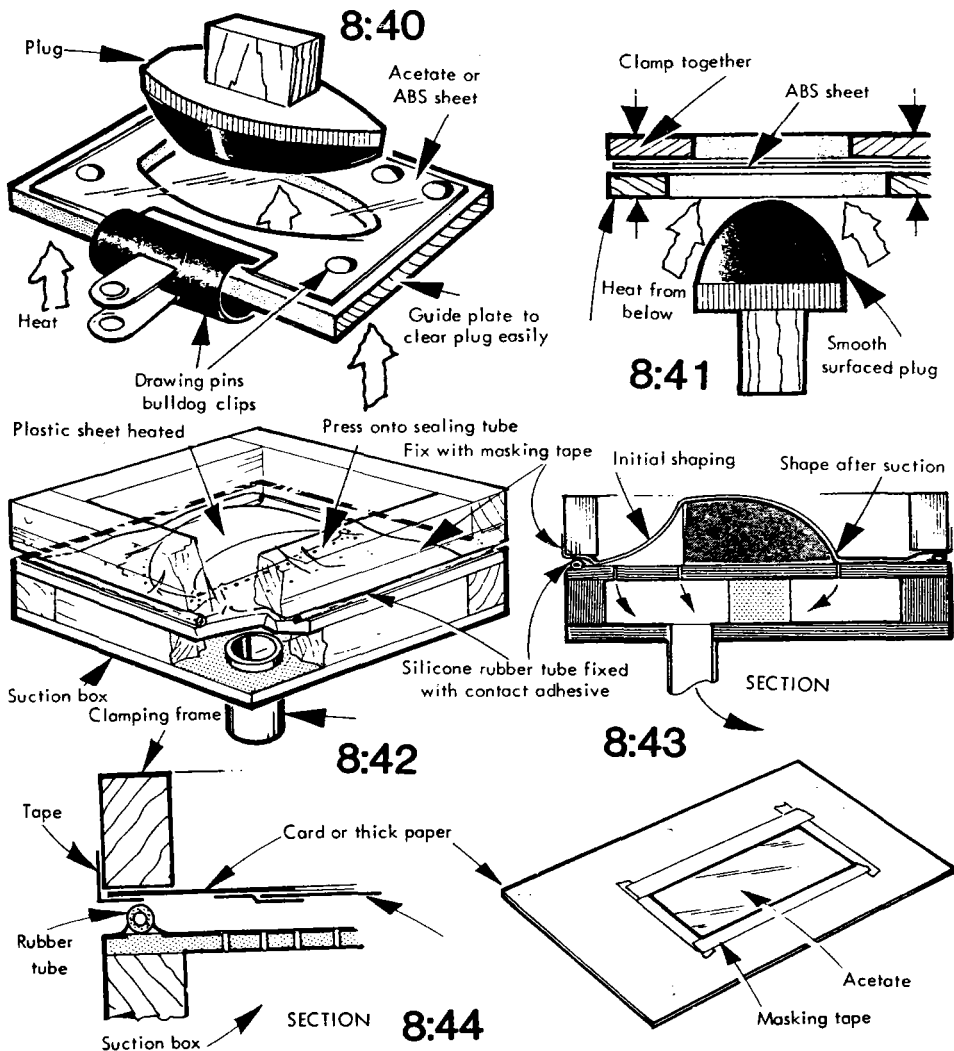

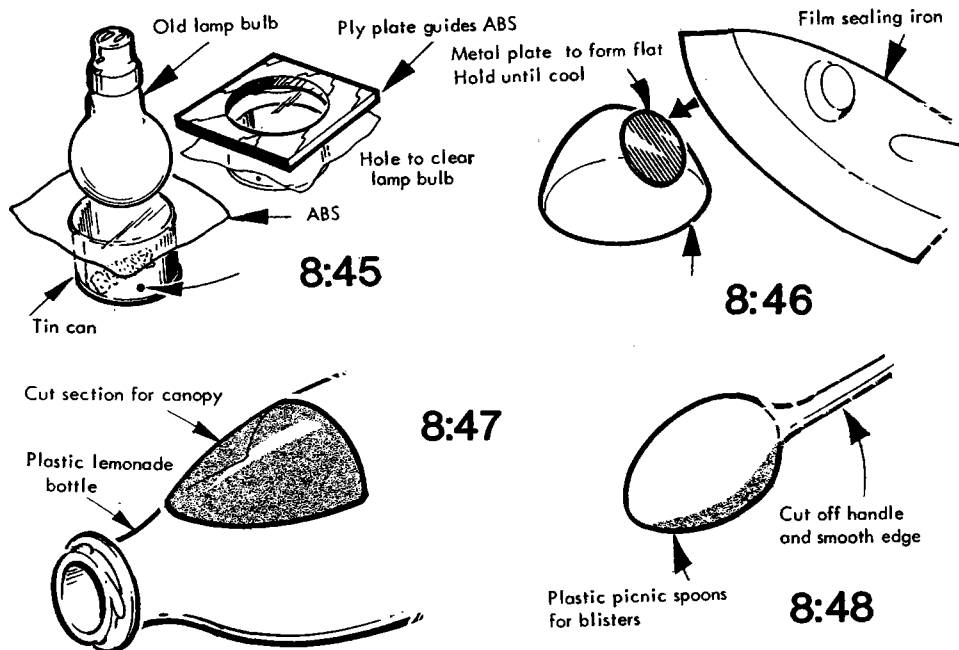

The important feature is a frame onto which the plastic is secured with masking tape. This is placed in the oven for heating and swiftly forced onto a rubber seal gasket on the vacuum box as 8:43.

What at first appears to be a gentle deformation of the plastic rapidly clings closely to the plug as the air is sucked out. Small pieces of plastic can be taped to a sheet of thick paper or card to save wastage (8:44).

### Quickies

Shallow circular blisters can be moulded by using an old electric light bulb, round door knob or other smooth hemispherical item as a plug. Choose a suitable tin can and ply plate to make 'astrodomes' and similar items, as 8:45. A spinner may be used as a plug in similar manner for producing, for example, the bomb aimer's canopy on a model 'Lancaster'. The flat window section is formed later by pressing a hot metal disc onto the moulded surface, where it will cause the plastic to re-form in this area (8:46).

If one is not too particular in respect of crystal clear glazing, cordial drink bottles can be cut up and reformed, but quite a good screen can be cut direct from a shoulder section of a fizzy drink bottle as seen in 8:47.

Little blisters can be made from whole or parts of plastic picnic spoons or those 5ml. medicine spoons – just the job for fairings over cylinder heads in a 'Jungmeister'.

# CHAPTER 9

## Better wings and tails

Templates  
Packing  
Details for camber  
Reinforcement  
Lighter construction  
Tail variations

See also Chapters  
4 and 11

Here are some extra details for improving those basic structures described earlier. Templates are always useful for ensuring accurate cutting, but a rib template can be used to cut many different sections, as shown in 9:1. The result of tilting the template to reduce the chord is similar to that of trimming off the underside of a ready cut standard rib, but the grain direction of the rib can be chosen to follow the lower surface. Alternatively, a template intended for a flat bottom wing can be turned over to enable symmetrical ribs to be made as seen in 9:2.

### Packing

Where washout is needed, a strip of balsa can be inserted under the trailing edge while the wing is being assembled, or before upper

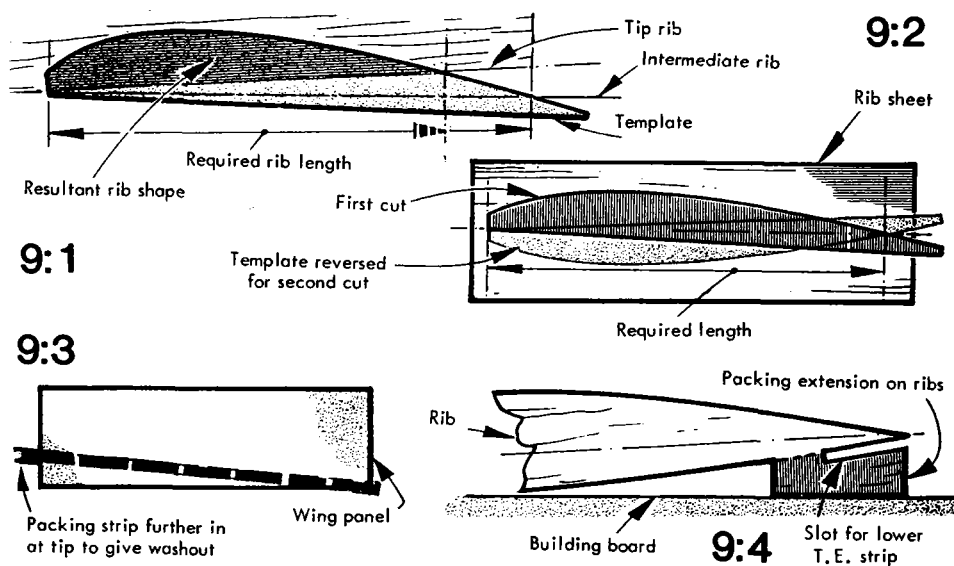



sheeting is done. The further the strip goes in at the tip the greater the washout (9:3). Some wings need extension pieces on the lower trailing edge of each rib, or those near the tip, to jig the wing to the correct washout angle, or merely to support it while building. The example in 9:4 is intended for 'V' type trailing edge strips.

When lower cap strips are to be fitted later, the spar and ribs are packed up so that they meet leading and trailing edges correctly as in 9:5. Where the section is undercambered, the trailing edge is often tilted, so it too needs packing as seen in 9:6, so does the lower wing spar or spars, even if there are no lower cap strips (9:7).

Lightweight wings may have several small section spars instead of leading edge sheeting. By staggering upper and lower spars, the rib strength is retained as shown in sketch 9:8. Thin sections can have large leading edge strips, shaped to form the lower curve. The trailing edge is usually so thin that double cap strips would meet. In this case, cap strips or no, gussets can be added at the junction of each rib and the trailing edge – both these details are shown at 9:9 and the general proportions of the gussets in sketches 9:10 and 9:11. Pay particular attention to the correct grain direction of the gussets, for they are to afford support to both ribs and the trailing edge itself (often thin and liable to tilt with the added support).

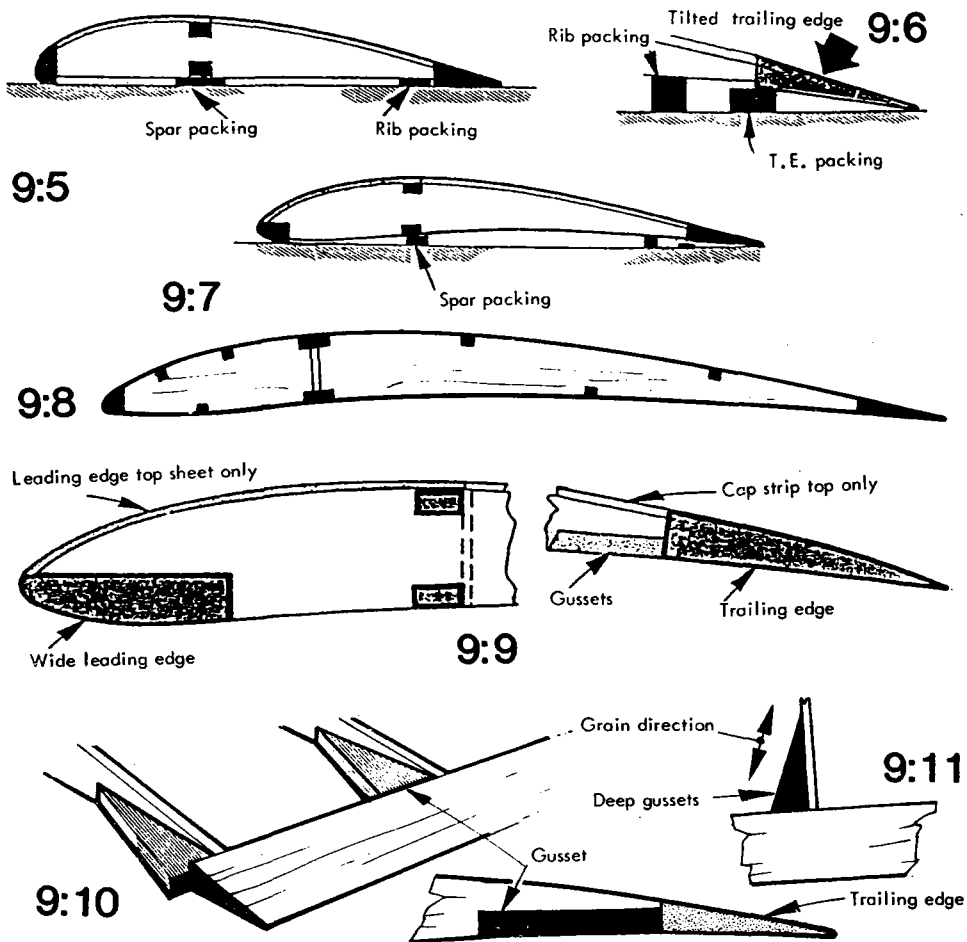

In sketch 9:12, we see a whole collection of useful gussets; at the tip to resist landing knocks, around the tip to main panel joint where dihedral change occurs and near the centre section, to reinforce the area where rubber bands restrain it. Those rubber bands can easily cut into a thin trailing edge, so let in a strip of spruce, shaped to the aerofoil section, and make doubly sure with piano wire, as in 9:13. Thin ply can be glued over the trailing edge instead, but it looks untidy. Note how the ends of the insert are chamfered off to blend the strength gradually into the balsa, thus avoiding weak points.

9:14 shows the staggering of wing brace strips for the same reason. If the braces themselves are tapered off as in 9:15, which compares both straight and tapered types, there should be less chance of weak points on each spar, leading and trailing edges.

Where notched full depth spars are used, remember that the effective depth is only that of the unnotched area, so to notch braces as in 9:16 is unnecessary and unwise. 9:17 shows the correct method; the taper is from the top so that the brace misses those notches and blends in nicely.

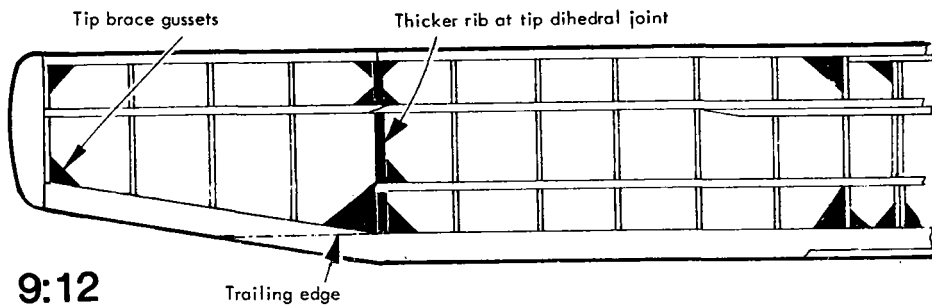

9:12

9:13

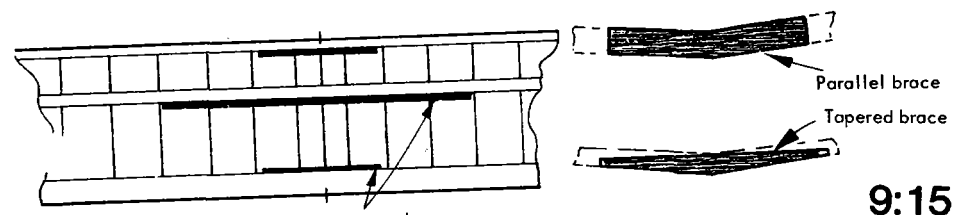
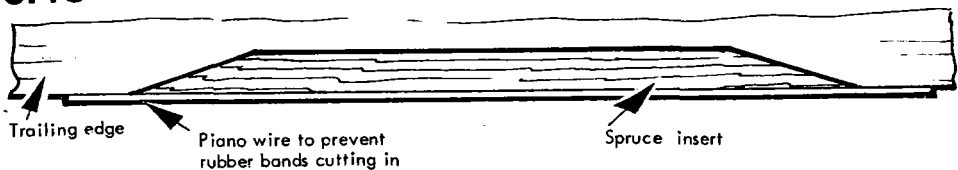

9:14

9:15

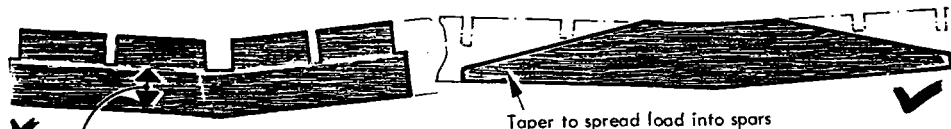

9:16

9:17

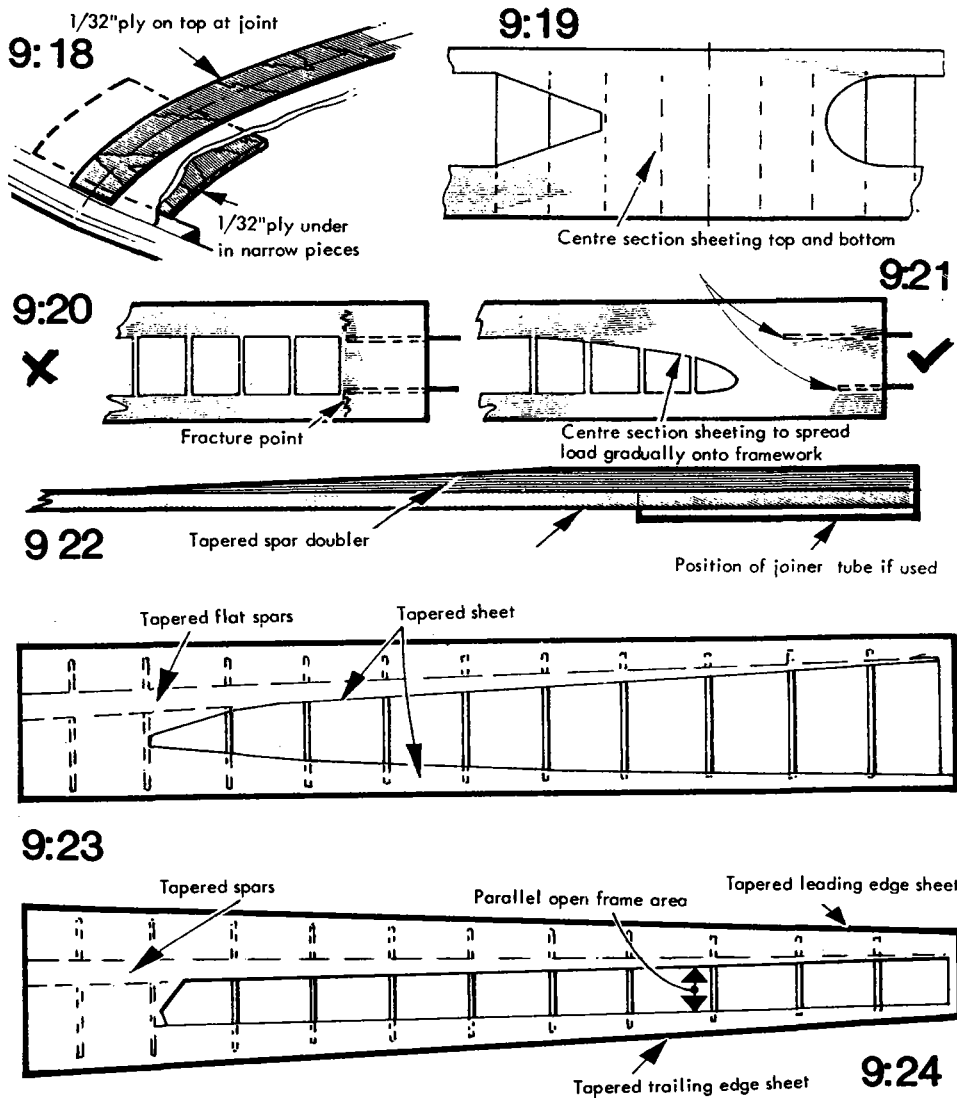

### Wing sheet platforms

A fully sheeted or stressed skin wing, or one which has a fully sheeted centre, as seen in sketch 9:18, can benefit from thin ply with the outer ply grain spanwise, under and over the centre joint. This can often look neater than bandage and glue, or glassfibre to reinforce the joint. The ply inside the joint must be in short pieces, otherwise it will not meet the skin. In any case, it is most useful at leading and trailing edges only.

9:19 shows variations at the centre of a partly sheeted wing. The sheet strengthens where there is the most stress, but has to be reduced in area, for lightness outboard. Never stop the sheet sharply as in 9:20. It has a potential fracture point (even if the braces or joining dowels end nearby). 9:21 is good; the sheet gradually blends into the rest of the wing and the dowels are staggered too.

Doubler strips on spars and spars themselves can taper (9:22). Even unusual looking arrangements like the plan seen in 9:23 will provide a good strength pattern; strong at the root, blending out to lightness at

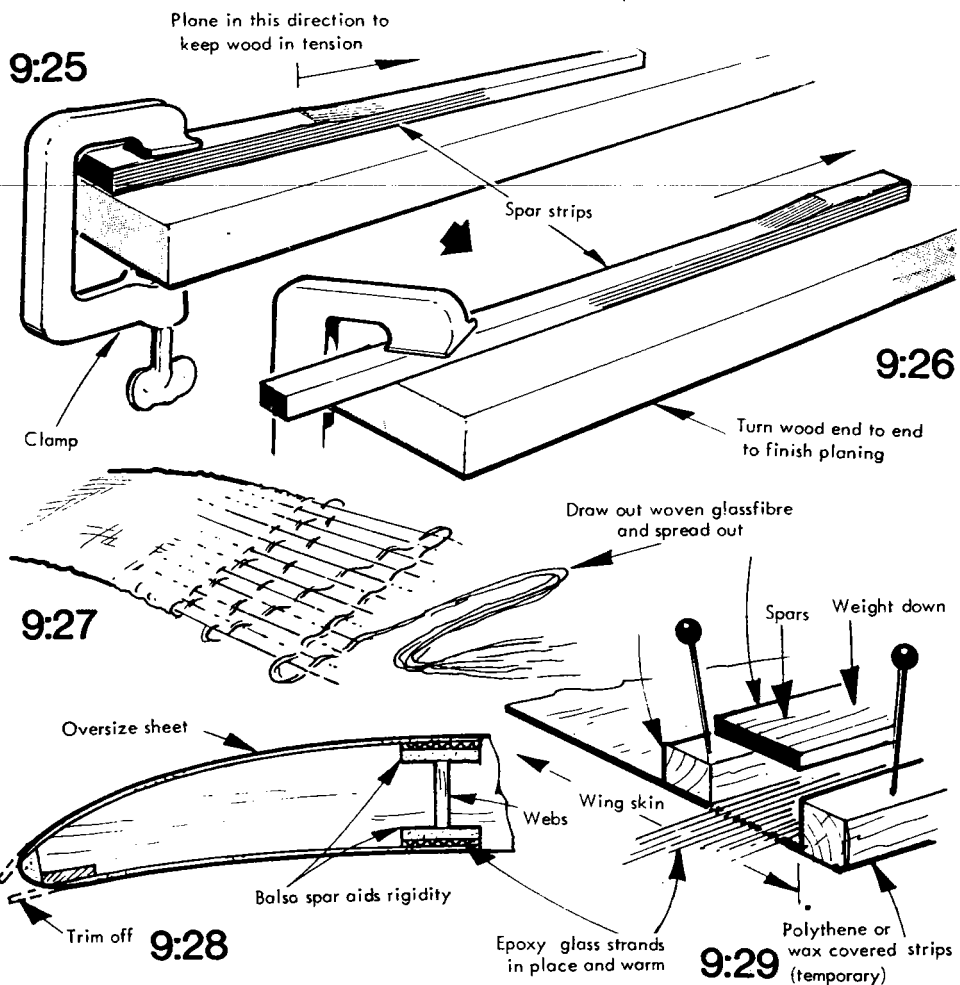

the tip. A wing which is tapered will be unnecessarily heavy at the tips, if the sheet areas are parallel. Try tapering the spars and sheet widths as seen in 9:24.

In discussing tapering spars and doublers, it is realised that some are spruce and need to be planed carefully to taper them. Small section timber needs treating gently. If it is pressed end-on up to a bench stop or the wall, the plane will probably buckle it. Plane it *in tension* as seen in 9:25, this way, it will lie flat while it is worked. There will be a short part of its length unplanned, because the clamp gets in the way, so turn the strip around end to end and re-clamp it as in 9:26. The thick end can then be reduced.

### Special construction

Contest models usually need a more technical approach to building, for example: thin wings have to withstand high stresses when launched. This tip relating to gliders shows how glassfibre strands may be unravelled from glassfibre tape for use in spar reinforcement (9:27). Glassfibre gives amazing strength to flat balsa spars and carbon fibre is even stronger. In 9:28, it is suggested that the spars are formed actually on the leading edge sheet, by sandwiching glass strands continuously

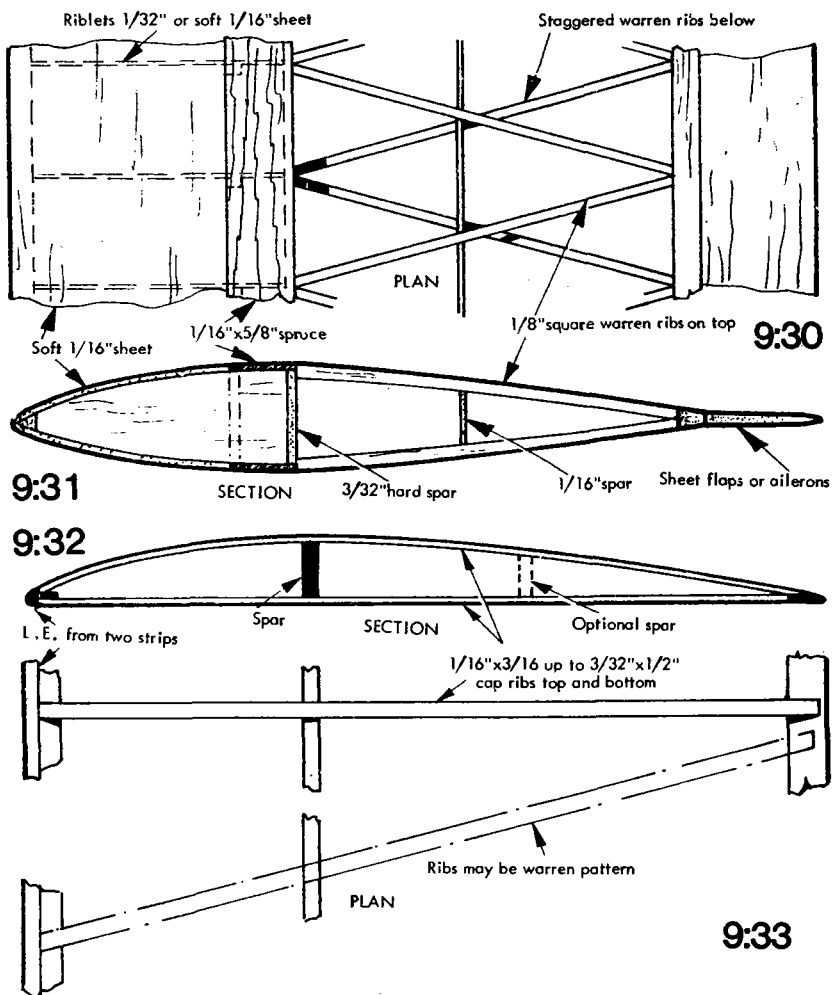

from root to tip between the skin and a thin spar, whose only purpose is to add rigidity. Ribs are built onto the lower skin and the top skin complete with spar added and trimmed at the leading edge. Sketch 9:29 shows how to assemble the spars.

A method used by the author for lightweight electric aerobatic R/C models is a 'D' box leading edge from thin sheet, edge jointed to  $\frac{1}{16}$ in. flat spruce spars. This is the major load bearing member with a vertical web/spar. Ribs, such as they are, comprise a lattice of  $\frac{1}{8}$ in. square strips of double warren planform to make a geodetic structure of very low weight. The whole of the trailing edge is a movable flap divided up as flaps and ailerons as seen in plan view 9:30 and section 9:31.

Ribs have been omitted altogether in the quick-to-make structure of 9:32. Flat strips are arched over a spar or two, to meet leading edge and lower strips joined to a small section trailing edge. The section is maintained by the depth and position of the spar(s). Free flight and sport R/C models have used strips of  $\frac{1}{16}$ in. x  $\frac{1}{4}$ in- $\frac{3}{8}$ in. and on simpler models, have been laid straight as normal ribs, with the occasional diagonal (warren) rib as seen at 9:33. Such a wing relies on the tissue covering for much of its rigidity and has to be of gentle camber to avoid cracking the cap strips, which of course have nothing to cap!

9:34

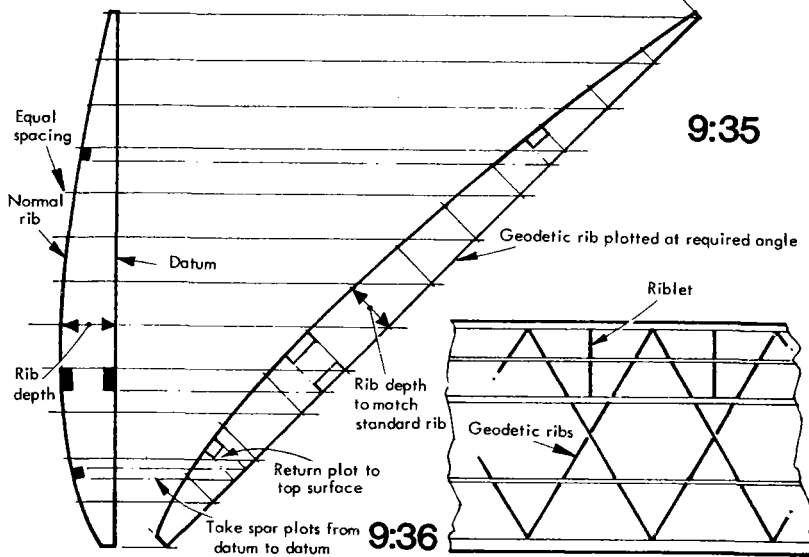
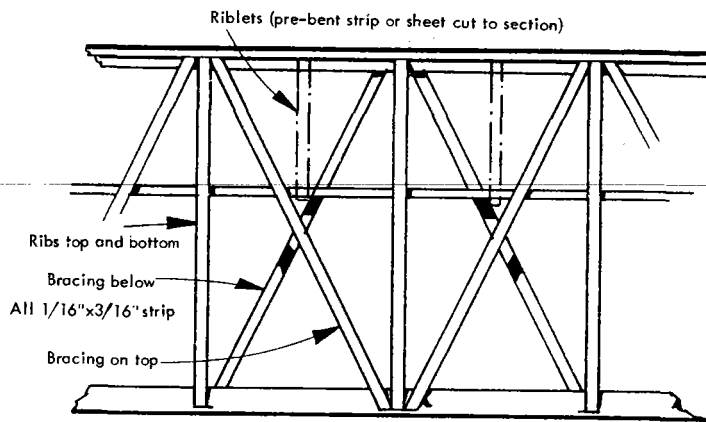

9:35

9:36

Continuing this theme further, strips of  $\frac{1}{16}$ in. x  $\frac{3}{16}$ in. were persuaded to form a light electric R/C model wing, following the crossed geodetic bracing method, and pre-bent cap strip riblets at the leading edge completed a wing lighter and more rigid than many traditional ones. The plan is seen at 9:34.

### Orthodox geodetic wings

First some extra ribs are needed; geodetic wings have diagonal ribs of the same depth as the normal ones – this means a bit of plotting . . . study 9:35. Divide the normal rib into equal stations and draw a line at the same angle to it as will be taken by the geodetic rib. This is the new rib datum line. Produce the station lines to meet it, then on each, perpendicular to the datum, mark off the standard rib depth. Simple enough, but wait; the top spars have to be projected from datum to datum, not to that new rib top. Return then back perpendicular, as were the stations. The new rib can be outlined, and the spar notches indicated – note how extended they are.

When the ribs are assembled, alternate ribs have to be cut, or half jointed, see 9:36. Riblets may be needed if the geodetic plan is not close spaced.

Some wings have standard ribs and geodetic ones at 45° or thereabouts. The geodetic ones may be thinner sheet, although on a contest rubber powered model, all might be 1/32in. thick. The geodetic ribs are usually cut to meet the main ribs (9:37). Warren bracing ribs can combine with normal ribs, adding rigidity, less effectively than true geodetic, but with less effort and weight, see 9:38. If the ribs are warren pattern only, without straight ribs, there is still rigidity, but spacing needs to be closer and riblets must be introduced to fill those wide gaps forward of the spar (9:39).

The warren or geodetic rib system need not always be carried forward of the mainspars, in which case more riblets are used to maintain that important aerofoil section, as in 9:40.

A lazy way of installing and shaping geodetic ribs is to be seen in 9:41, but only do this if the structure is tough (flimsy, soft sheet will be damaged easily). Rectangular blanks of sheet are cut and glued in position between the full ribs proper. This is done preferably before fitting the top spars, because they will be difficult to thread in. When dry, they are sanded in situ, down to the level of the full ribs, taking care not to sand the latter accidentally.

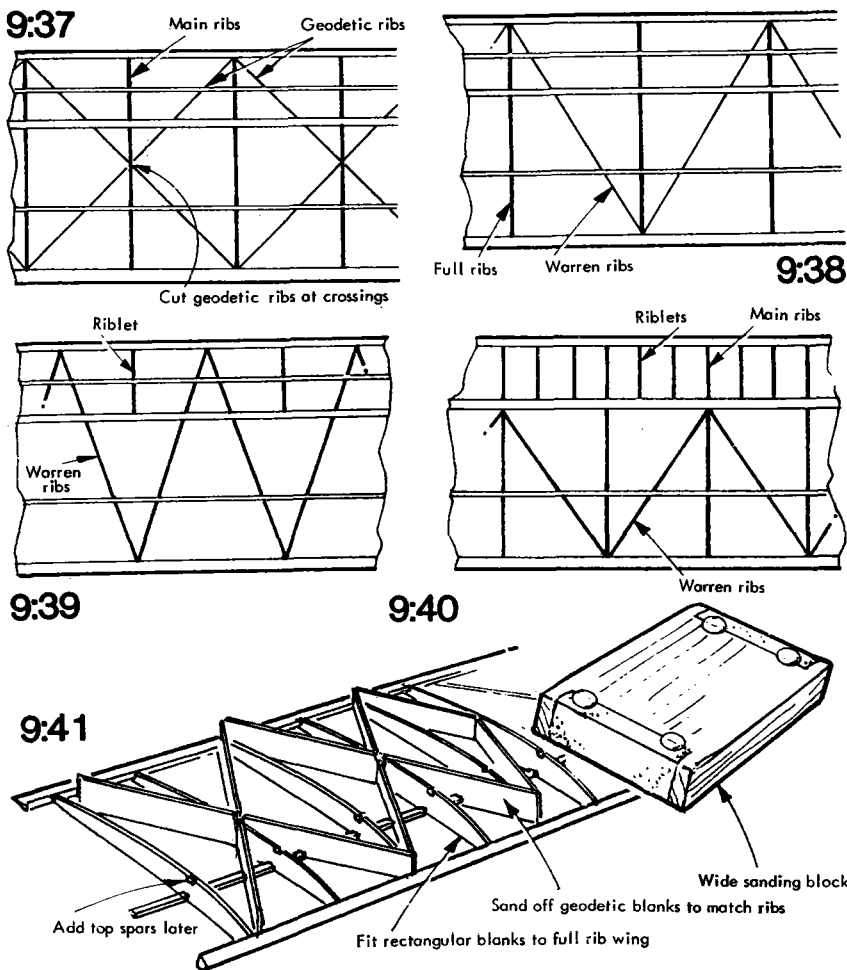

## Strip bracing

Normal wings can be made more rigid by adding square section strip from top and bottom spars to the trailing edge, forming a geodetic pattern. They lie below the covering line on top, but on it below, if the wing is flat bottomed aft of the spar. It does not work on deeply undercambered wings. The system is shown in; 9:42.

A certain amount of weight can be saved at the leading edge by omitting the lower sheet and substituting warren bracing from lower spar to leading edge strip. Pre-bent cap strips can then extend to the leading edge, in one piece if desired, all per 9:43.

## Tougher tails

Although sheet tails have been dealt with earlier, these few dodges should help in detail. Swept back tail surfaces can be prone to splitting, due to the spanwise grain pattern. 9:44 shows how to lay the sheet out in sections edge-joined to support the hinge line (C/L and R/C models). In 9:45, the grain is parallel to the edges, but because this means that the tail has to be cut in half, flat ply or hardwood braces need to be let in. For dihedralled or anhedralled tails, tough ply or wire braces shaped to the angle are inset.

Ends of elevators and tailplanes (or rudder and fin) benefit from 'anti-split strip' butted on (9:47). Unless the model is scale and requires otherwise, use bluntly rounded edges. (9:48).

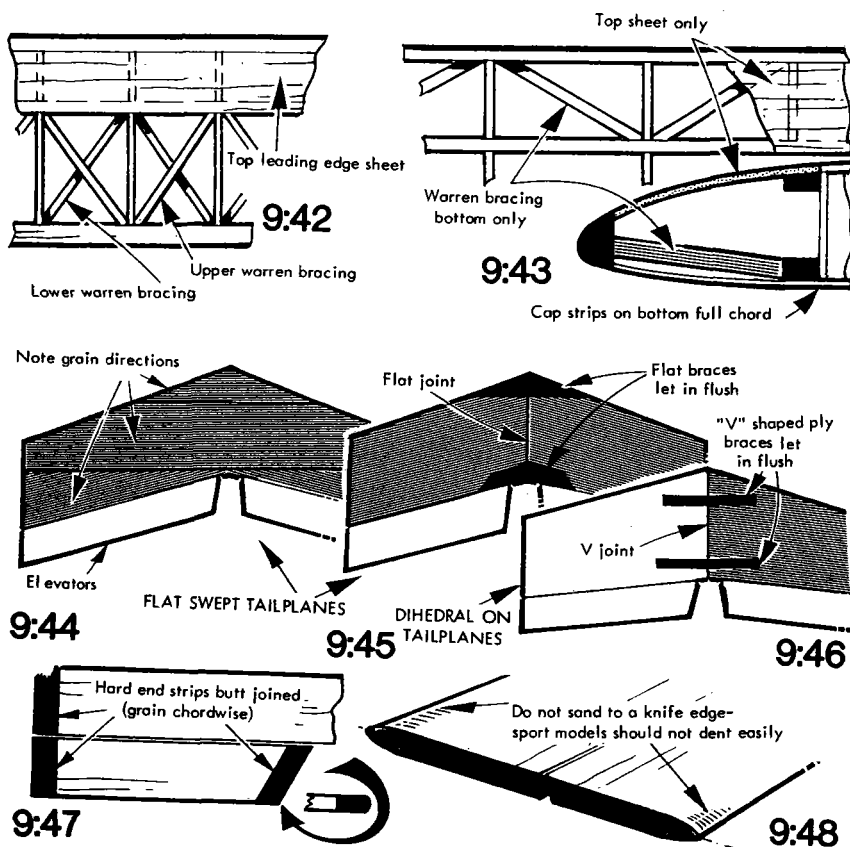



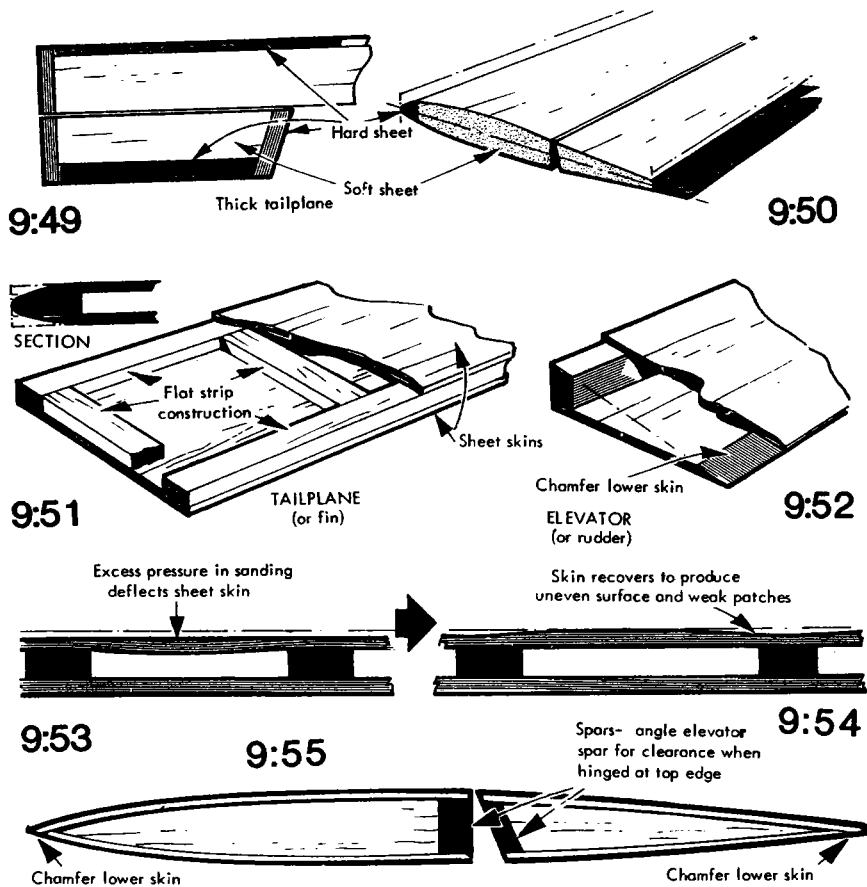

The edges are best protected on soft sheet tails (soft because they are thick in section). Hard sheet, or even thread glued on, will do the trick – see 9:49 and 9:50. Tail surfaces can be built up as seen in 9:51. So simple and weight saving, this. The structure can be laid in the bottom sheet and when dry, the top sheet added. Tapered sections for rudder and elevator are made just like the built-up trailing edge section described earlier and seen in 9:52.

It pays to sand the outer face of the sheet covering before building the tail, because if sanding is done vigorously, as in 9:53 the skin will bend between the structure and get sanded thin in some places and not in others. It then pops back as in 9:54, leaving an undulating surface with patches of partly sanded finish.

Whenever turning a component over after sanding one face, in order to sand the other, place it on a smooth, clean surface, preferably with soft packing, to avoid scoring it accidentally on blobs of dried glue and wayward bits of wood.

That double surfaced tail can be made over pre-shaped strips to give it a streamline section, omitting leading edge and trailing edge in the process, as seen in 9:55.

It is often convenient to make tailplane and elevators in one piece and slit apart when finished.

For lighter models, or those requiring light control surfaces, warren rib layout is excellent in retaining rigidity, as seen in sketch 9:56. Flat

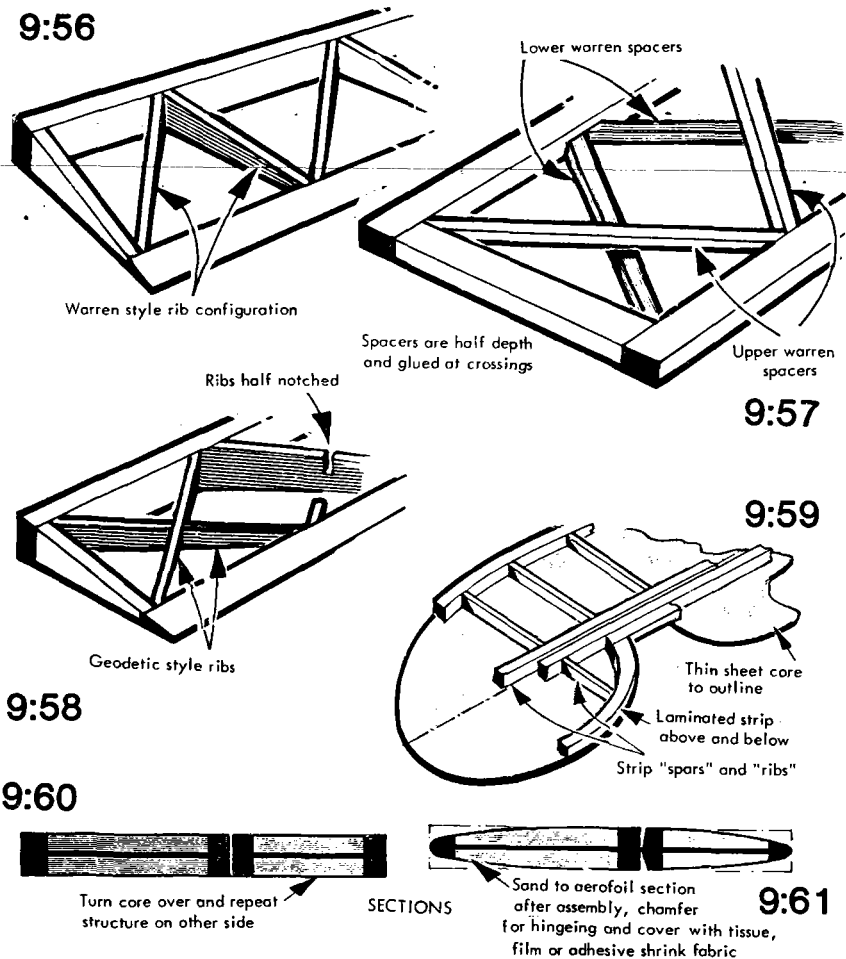

plate tails, often prone to warping, can be made warp-resistant by using the double braced geodetic method. Here the bracing strips are half the thickness of the outline strips, one warren plan set are laid in touching the building board covering, then a second set are placed in top, half a bay out of phase, and glued at the crossings; all as seen in sketch 9:57.

Back to the elevators again . . . geodetic ribs half notched together are the job for these tapered sections as in 9:58. So, on to scale-like tails . . . How often has an interesting plan shape been changed because it was difficult to build? A method beloved by scale modellers is shown in 9:59. A  $\frac{1}{16}$ in. sheet core is cut to the outline of the tail and pinned flat, for stripwood to be added in the form of spars, which are continuous, and ribs. The edge is formed by squeezing strip between finger and thumbnail to encourage it to follow the outline. Glue will restore its strength when in position, but purists could laminate the sharper bends. Having completed one side, the structure is turned over and a repeat set of strip added to the other side (9:60). When dry the whole tail is sanded to the appropriate aerofoil section, or just rounded off at the edges, slit and chamfered at the hinge line, and tissue or fabric covered as in 9:61. Wherever there is a stress point, fill in solid (i.e. at the fuselage junction, strut points and hinges).

# CHAPTER 10

## Hingeing control surfaces

- Hinges
- Split elevators
- Non-fixed tails
- Ailerons
- Flaps
- Spoilers
- Variable camber
- Slats/slots
- All-moving surfaces

See also Chapter 9

The most elementary form of hinges can be seen in the control-line model, where apart from the larger versions, the method seen in sketch 10:1 will suffice. An alternative, less time-consuming method is the 'clothes horse' hinge of 10:2. To preserve the flexibility of the thread or tape hinges, apply a little candle wax to the area where they cross the sheet edges. When dope or paint is applied, it will not then soak into the material to stiffen it and make it brittle.

Radio control modellers often use leaf and pin hinges, which offer a more precise pivot, but for control line models, some examples are a little stiff, so disassemble and cut a fraction away from the meeting faces, as in 10:3. Pin 'point' hinges as in 10:4 are convenient to install, but fit in wood of  $\frac{3}{16}$ in. or thicker.

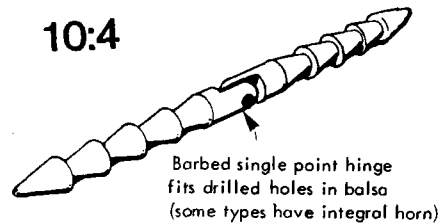
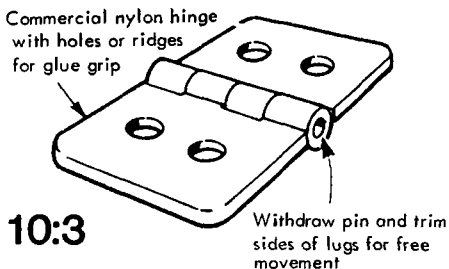
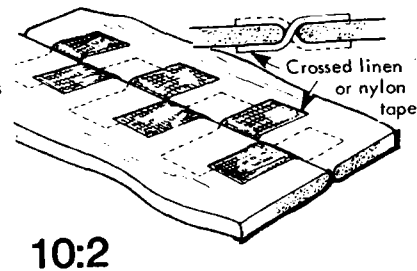
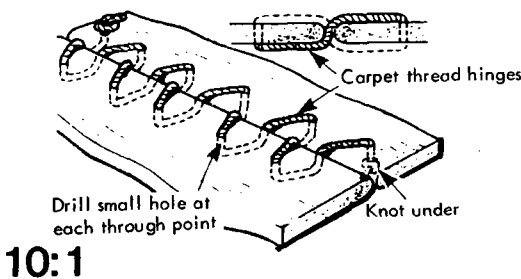

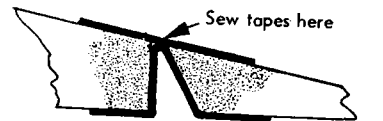
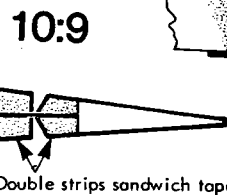
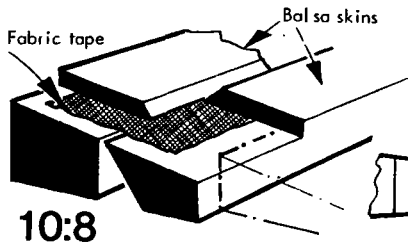
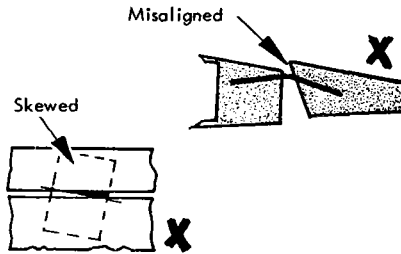
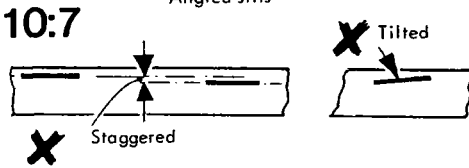
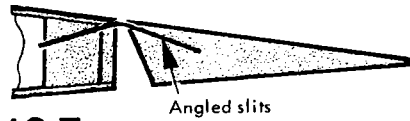
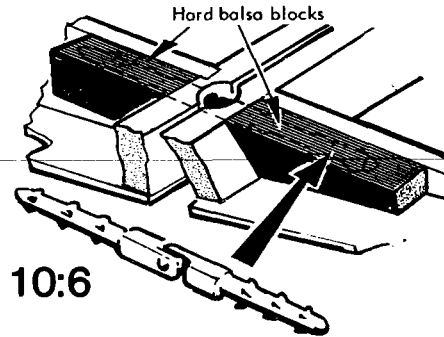
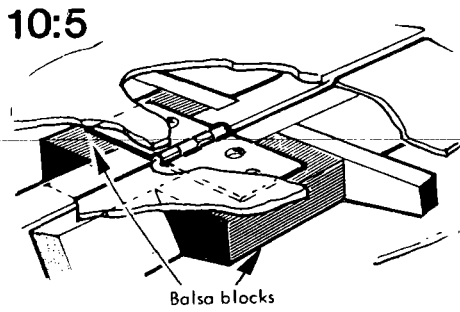

Some designs require the hinge to be close to the top surface. Leaf hinges are most convenient, as seen in 10:5, and here the sheet skin traps them for security. Scrap blocks support them below and provide more area for adhesive. If using epoxy or superglue to fix them, be sure to wax the hinge pin area, as a resist. Fold the hinge and dip it just into a tin lid containing hot candle wax, or use boot polish cold.

The hinge point in 10:6 will not have its pivot so near the top of the joint, so file a little clearance around it and ensure that the pivot is horizontal, as if twisted round it will be stiff. Those chamfers in the meeting edges of control surface and the fixed aerofoil need to be wide enough to allow the surface sufficient movement without straining the hinge.

10:7 shows that a top-hinged surface can have the leaves of the hinge angled down into better areas of grip. Watch out, however, that the slits for the hinges are aligned on both sides of the hinge and are along the hinge line, in both plan and rear views. Misalignment causes friction, loosens the hinges and warps the control surface. If it does not drop under its own weight, re-check.

10:8 shows a piece of fabric under the skins as a continuous hinge, 10:9 is similar. Two strips of fabric tape sewn down the centre can be glued outside as in 10:10.

## Film hinges

Heat shrink film can be used as hinges, full length at the covering stage. 10:11 explains the sequence. Do not omit that packing in 'b'; it prevents the film shrinking the joint too tightly, making it stiff, but remove it afterwards!

## Split elevators

The rudder may extend across the elevators, so cut them for clearance and re-join with a hardwood strip. Offset the horn, though; central holes will weaken the joiner. Hard balsa end strips also reinforce here and epoxy skins prevent the wood being crushed by the tightening of the horn bolts. (10:12).

Wire joiners can fit into slots in the ends of elevators if taped and epoxied for security, as in 10:13. The tube is important if the tail is held on by rubber bands. It is glued to the tailplane and prevents the bands restricting elevator movement.

10:14 shows how to arrange chamfers for free movement and 10:15 a recessed hinge design for close gaps (air escaping through a wide

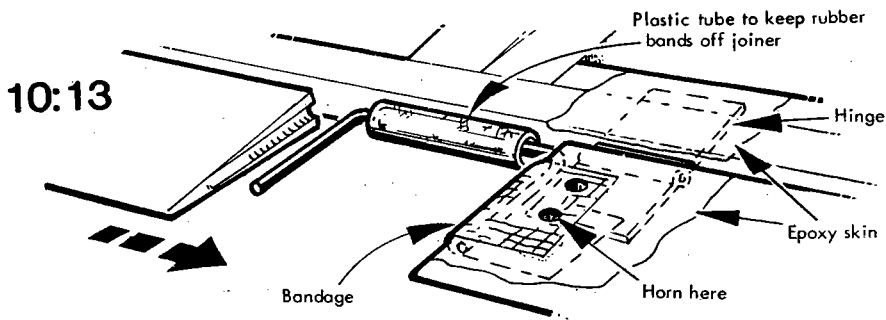
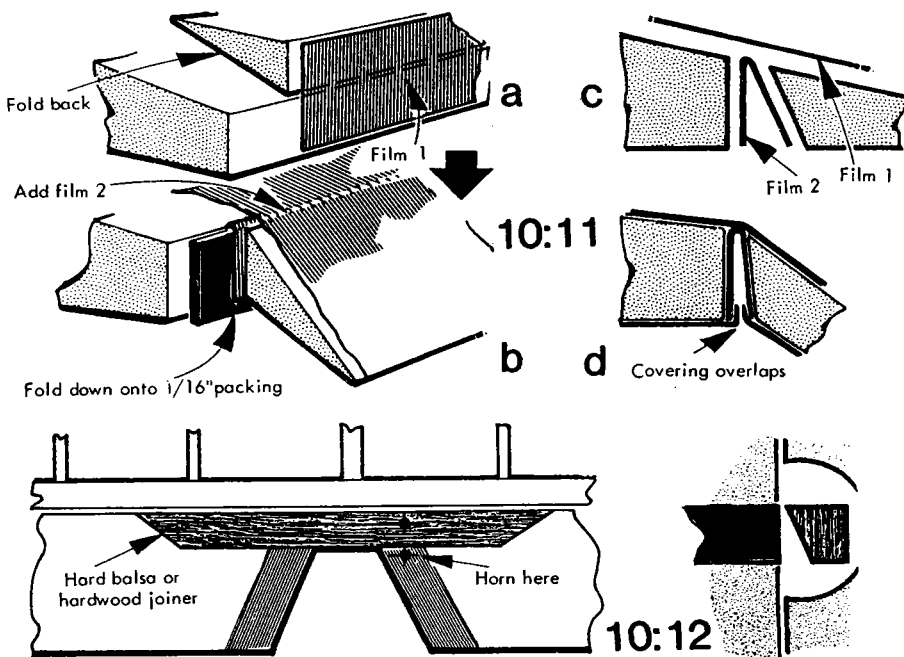

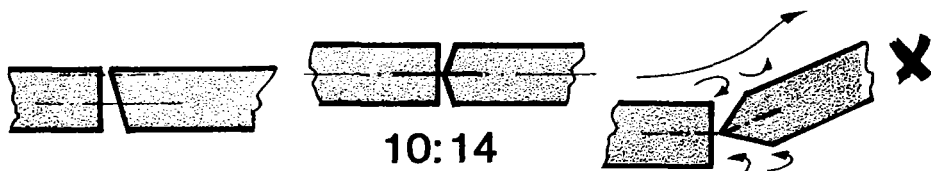

10:14

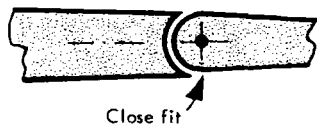

10:15

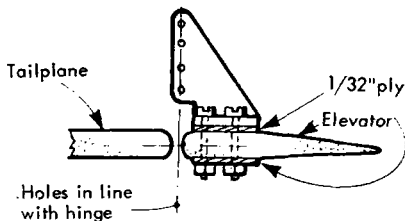
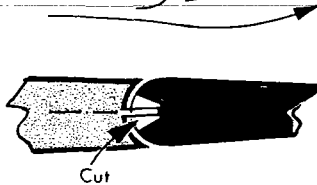

10:16

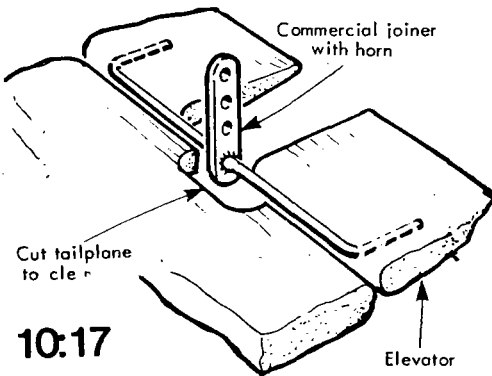
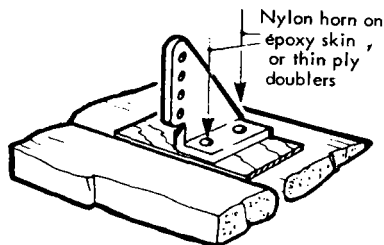

10:17

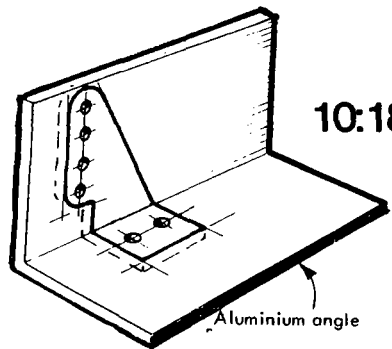

10:18

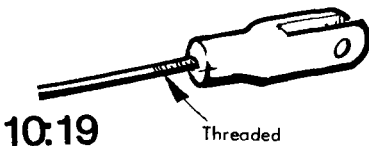

10:19

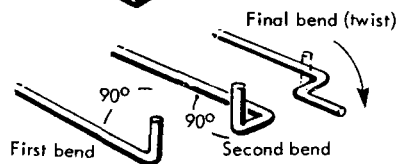

10:20

hinge-line spoils efficiency). 10:16 illustrates horn fixing. Keep the holes in line with the hinge pivot for accuracy. Commercial joiner/horns are easily installed (10:17) cut a clearance notch in the tailplane. Horns can be cut from aluminium angle (10:18), obtained from D.I.Y. shops. Drill the pushrod holes to fit the wire to be used or a commercial clevis (10:19).

Clevises are adjustable and clip into the horn. To remove from the horn, gently prise apart with a small screwdriver. Sketch 10:20 shows how to bend a pushrod (16S.W.G. cycle spoke or piano wire). One clevis is needed on each pushrod if adjustment is to be made.

The position of horns depends on the clearance in the model, but the straightest route is the best. A hollow fuselage allows a central horn to be used, as in 10:21.

If the horn must be outside (10:22), the crank in the rod must be gentle, or movement could be lost. Dihedralled hinge lines (10:23)

dictate that two horns and a split rod are needed, so too with a swept-back hinge line (10:24). When you've built one, it will be apparent.

### Knock-offs

On a radio control model, movement of the tailplane on its retaining rubber bands will change the elevator angle (drastic!) 10:25 suggests a locating dowel to prevent fore and aft movement in flight. This is not so pronounced with a vertical pushrod, as in 10:26. A pivoting tail is acceptable too (10:27).

### Ailerons

There are four basic classes, as seen in 10:28. The strip type can be driven from the inner end, via a short torque rod, (like half an elevator

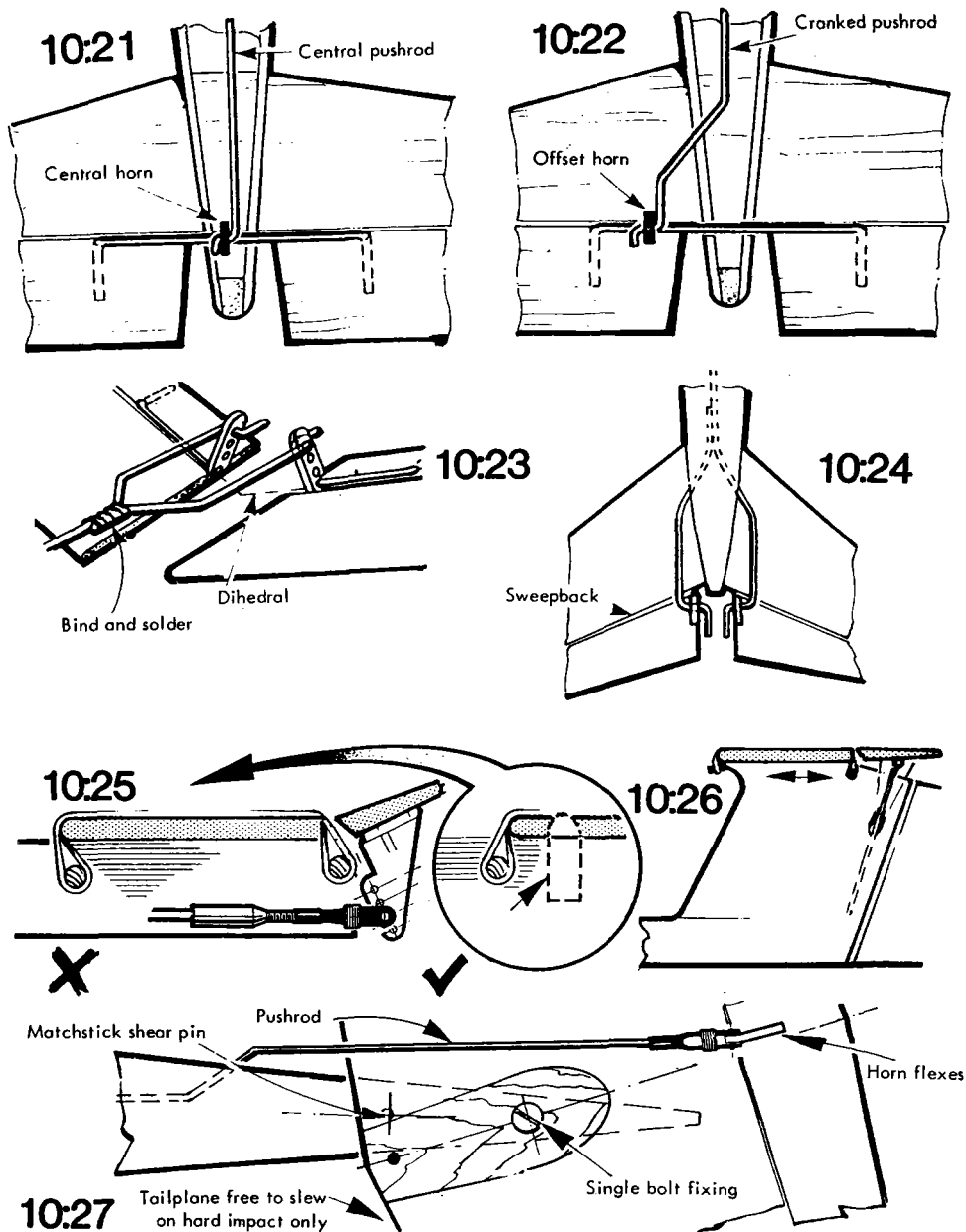

horn/joiner). The others are operated by a bowden cable curved to turn 90°, or better still, by a 90° bellcrank. (Books on radio control will explain this. If it were all described here, the book would be unwieldy) 'Balanced' means that an area at the tip goes down, as the main surface goes up, to reduce the forces on the controls. (More of a full-size practice here, but copied on some scale W.W.I. subjects).

A rear spar carries the aileron as in 10:29, but a short one has to be well supported inboard as in 10:30. It is usual to make the wing in one, then cut the aileron free and face its raw edges. Strip ailerons, however, can be shaped and added later, as in 10:32.

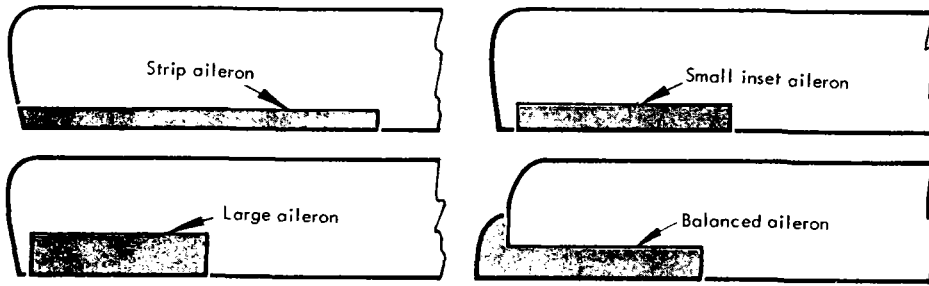

10:28

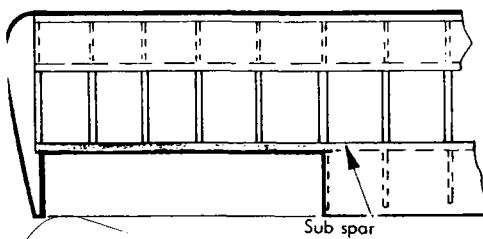

10:29

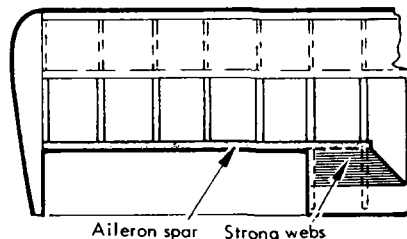

10:30

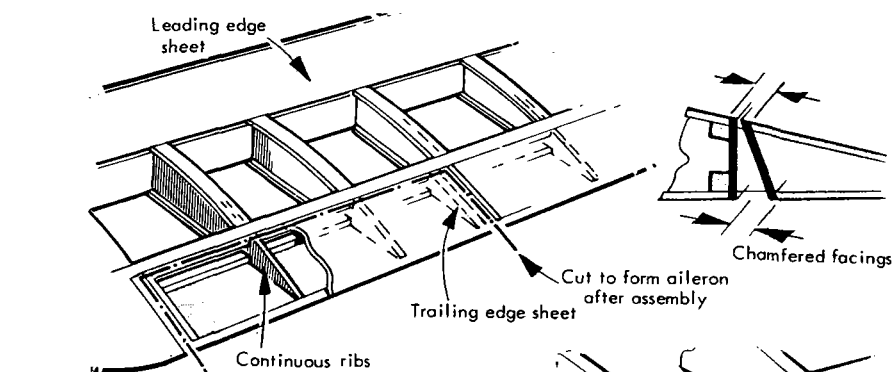

10:31

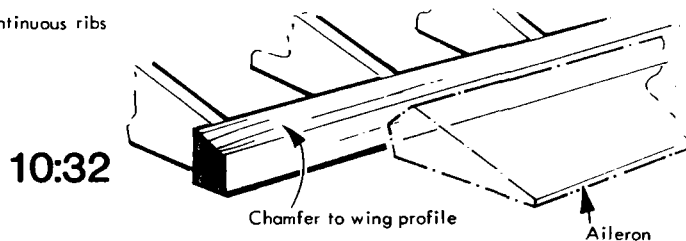

10:32





10:33

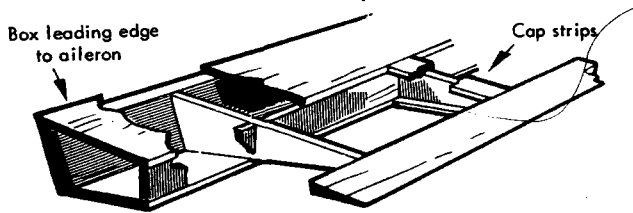

10:34

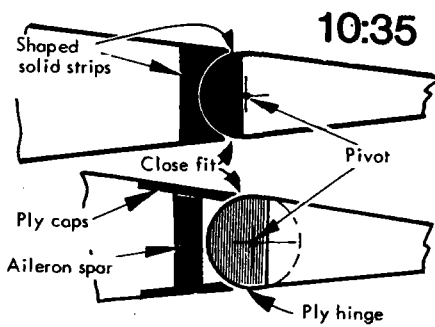

10:35

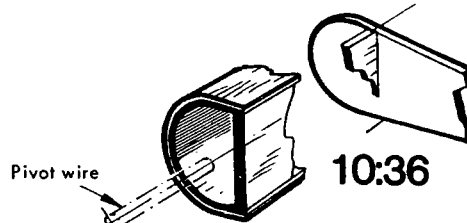

10:36

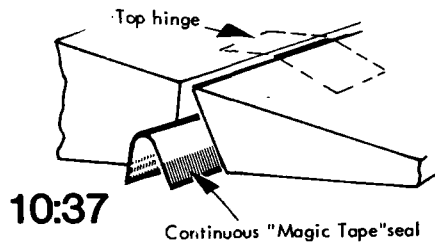

10:37

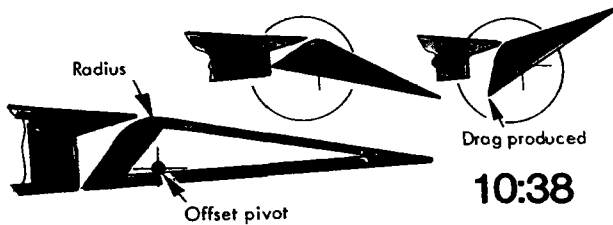

10:38

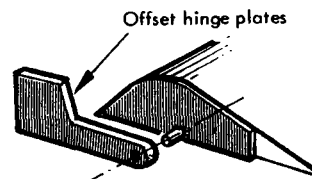

When shaping the trailing edge of the wing to meet an aileron of the strip type, check that it blends in, as in 10:33 which shows right and wrong. 10:34 will help those needing wide chord ailerons and 10:35 provides details for alternative minimum clearance hinges. Why bother, you might say . . . 10:37 shows a strip of 'Magic Tape' in the hinge chamfer to bend freely and prevent air leaks. Tape on top serves too, but is more visible.

Another type of aileron is the Frise pattern. This is hinged offset so that it gives drag in the 'up' position, aiding turns on some models (and full size). The hinge is well back on long plates and the top of the leading edge is radiused to fit an overhanging top surface on the wing (10:38).

## Flaps and brakes

This page shows lift and drag producing control surfaces. Flaps go down to aid lift and can share the same hinge line as the ailerons, as in 10:39. If the top moves up at the same time, it becomes an airbrake as well (10:40). The underside of the trailing edge can be split to lower, as a lift augments. This is easy to model; recess the lower skin and make the flap from thin plywood. Stiffen it, if needed, with a piano wire leading edge epoxied on. (10:41).

An interesting co-axial linkage was seen on a contest aerobatic R/C model. The ailerons are driven by a torque rod within a flap torque tube, all supported in brackets as in 10:42.

Gliders are not so complicated. A thermal soarer can be slowed to lose height by raising a ply panel on the wing surface, as seen in 10:43. How does a cable open it? Run a fine cable to the wing L.E. and back to the rear edge of the spoiler.

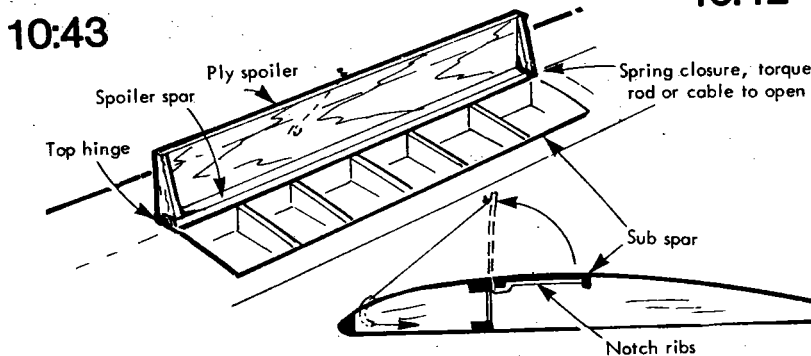
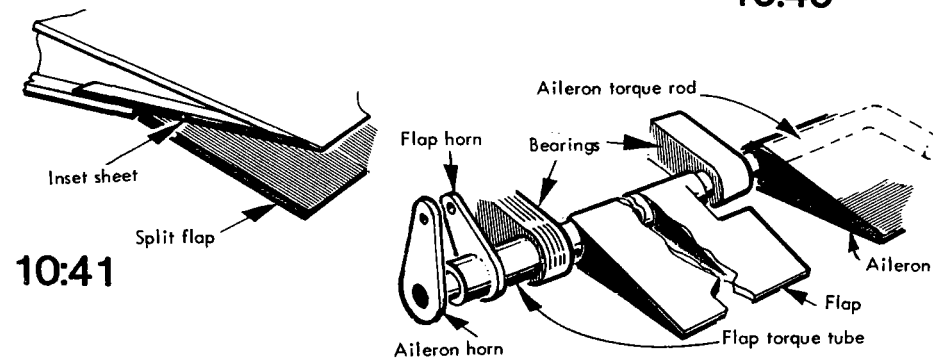
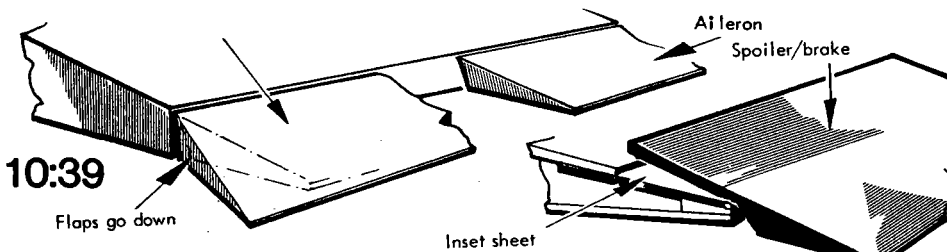

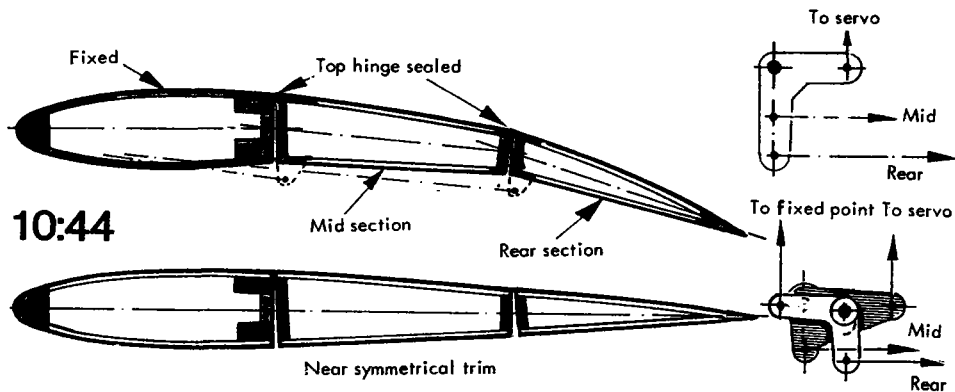

10:44

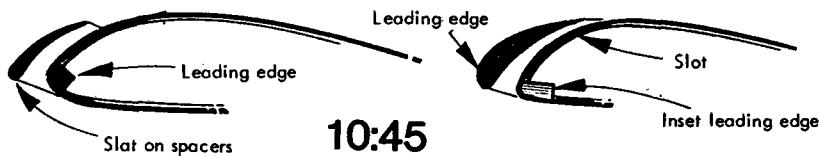

10:45

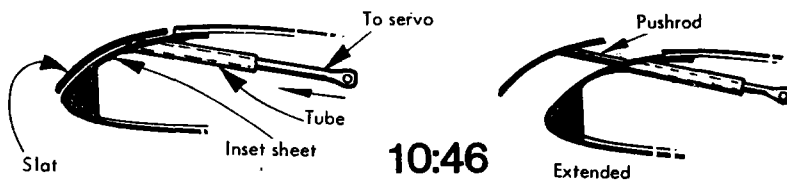

10:46

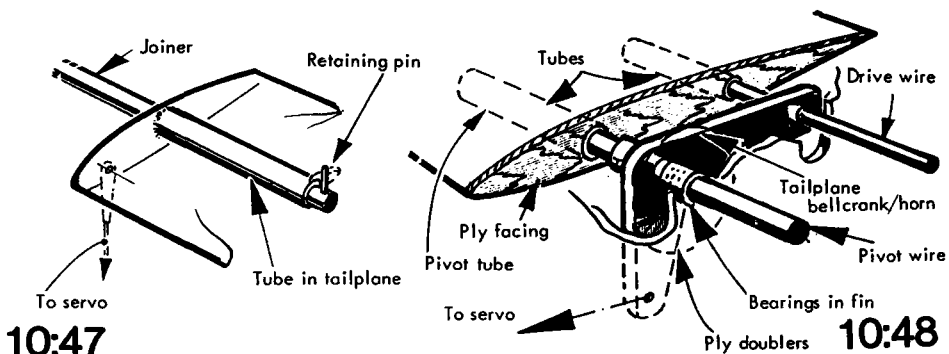

10:47

10:48

### Variable camber

This type of aerodynamic trickery, developed for f/f power climb, was used successfully on an aerobatic electric model. It was possible to launch the model inverted and climb it with a cambered aerofoil, then change to fully symmetrical for some manoeuvres, changing to normal cambered profile when upright, for high lift. Those hinge lines must be tape sealed and the linkage arranged as in 10:44 (right) to give more movement at the rear section than that of the centre strip. With adequate power, control line type opposed flaps work almost as well!

10:45 shows the difference between added and inbuilt wing slots. These improve stall resistance at the wingtips. Construction is obvious. Movable slats, as in 10:46, can be spring loaded to pop out as speed decreases (full size) or (safer in model use) pushed out by a servo. They are a little vulnerable in some low wing subjects. All-moving tailplanes pivot in a rod as in 10:47 (vertical pushrod) or 10:48 (normal linkage).

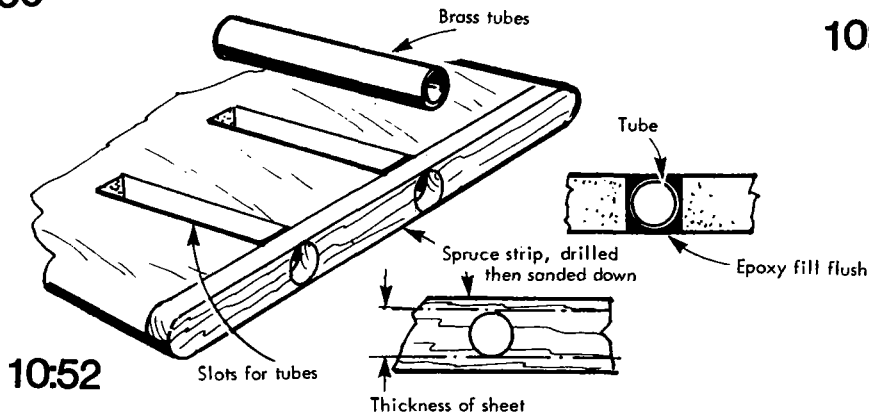
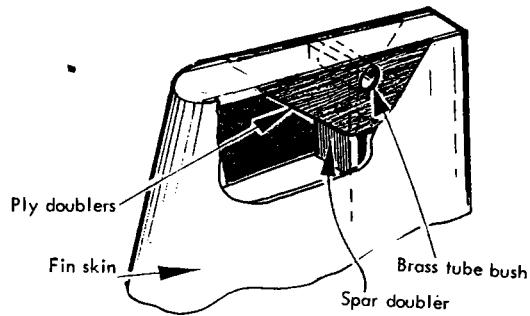
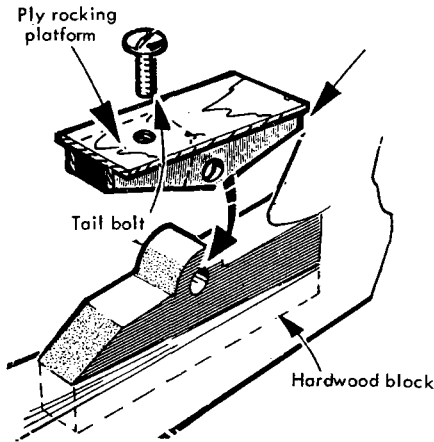
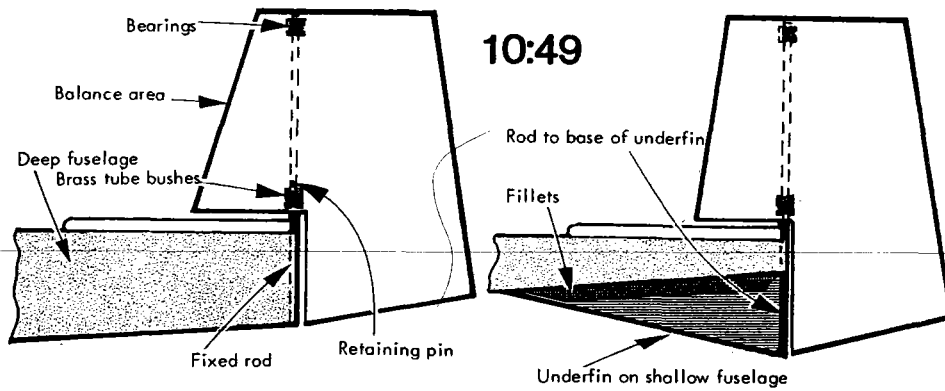

All-moving fins can be aerodynamically balanced and pivoted on a rod, as in 10:49. Still in the realms of radio control, the rocking tailplane mount allows for a single bolt mount to hold a 'slewable' tailplane, useful on rocky slope sites or for reproduction vintage models, where the all-moving tail is to appear 'fixed' and without elevators – 10:50 explains. The same method can be applied to a 'T' tail; by reinforcing the fin top, as in 10:51. Use a vertical pushrod.

Sheet tailplanes are sometimes thin, so the brass tubes into which the pivot and drive wire joiners fit have to be *slotted* in. Sketch 10:52 shows a root reinforcement idea. It should save some splits in the tailplane.

# CHAPTER 11

## Wing and tail attachment

**Bands**  
**Tongues**  
**Bolts**

Free flight, radio trainers, sports models and control-line trainers usually have need for really resilient wing fixings. Traditional methods of securing the wing, and in some cases the tailplane, employ a number of strong rubber bands hooked onto protruding dowels in the fuselage and taken over the wing or tail. The basic set-up is sketched in 11:1. Note that the dowels pass through strengthened parts of the fuselage and are located so that the rubber bands pass straight down (or up) from the wing. Space has to be left between the wing and the dowels, so that the bands can be hooked on easily. Friction between the bands

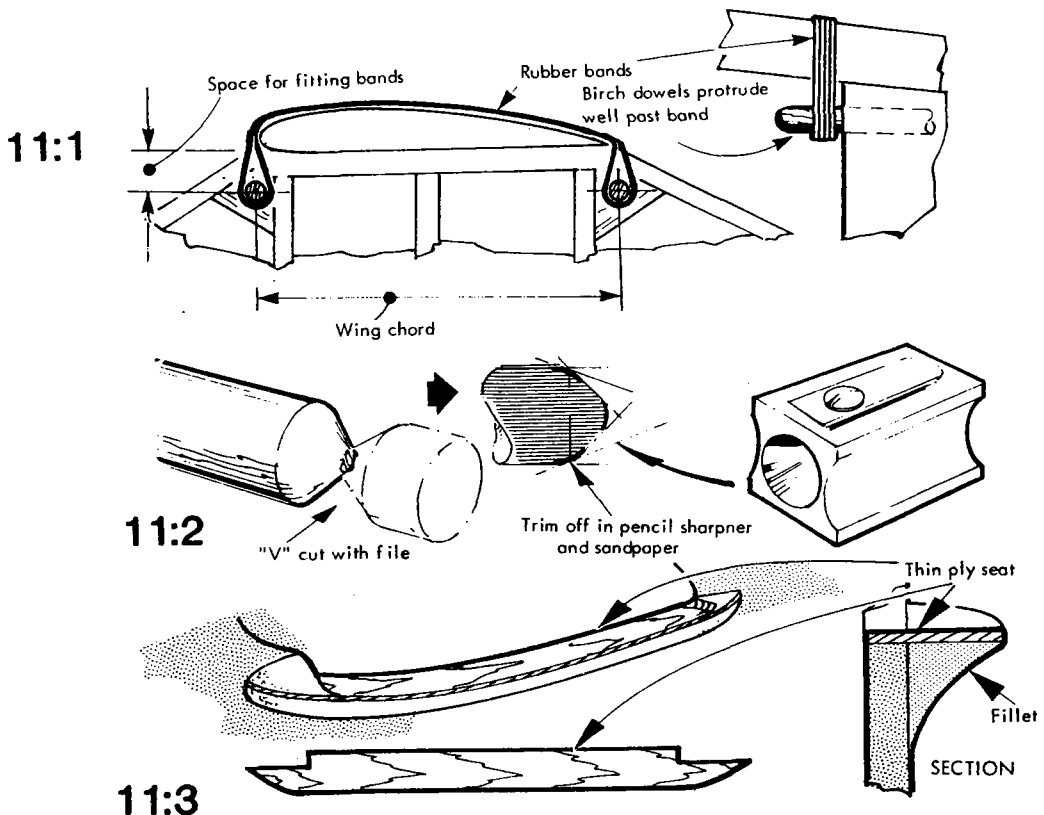

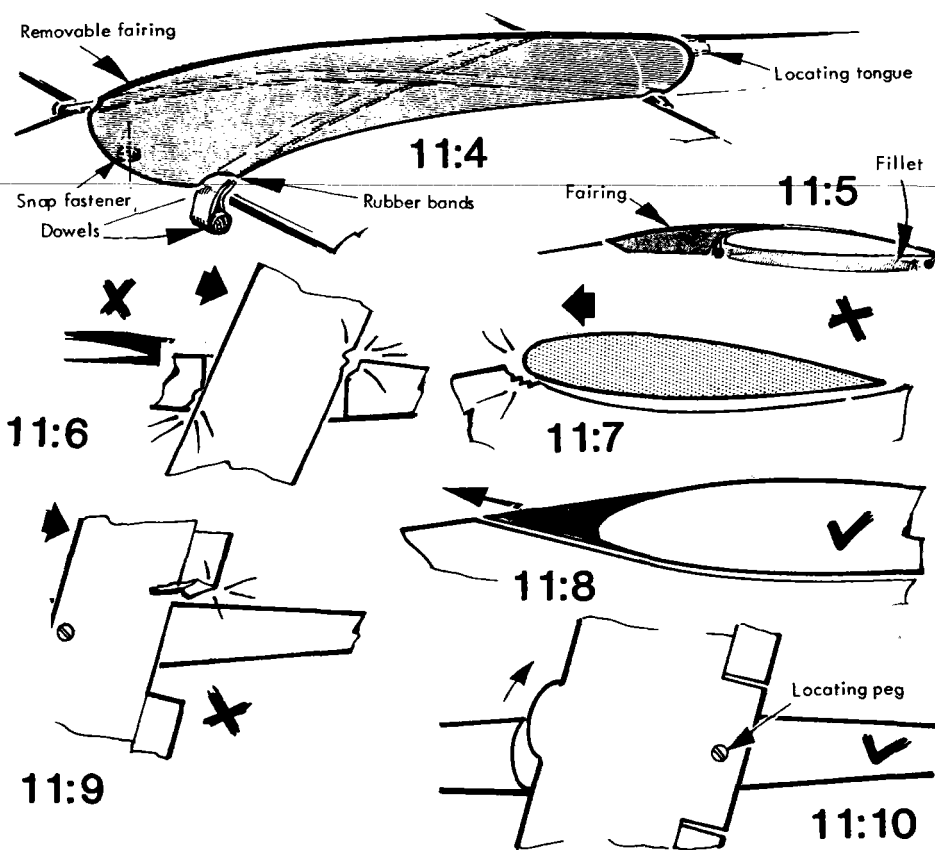

and the wing, and between wing and fuselage, resists movement of the wing, but a hard blow to the wing should cause it to siew, or the bands to break, thus minimising damage to wing and fuselage. 11:2 shows how to cut and finish the dowels so that they do not damage the bands. Bands alone are not the only aid to security; 11:3 shows a wing seat detail. The wing should sit on its platform or seating without rocking or sliding easily. If it moves about in flight, the model will lose its trim and become unstable. A strip of thin adhesive foam or silicone rubber caulking ensures a good fit. (Place polythene on the wing and sit it on the wet silicone rubber, it can then be lifted off after curing and the polythene stripped off).

Do you object to seeing rubber bands? 11:4 shows a streamlined fairing made from balsa or moulded in ABS. This can be continued forward as a canopy or hatch cover as in 11:5.

Try to avoid seating the wing in a stepped recess fore *and* aft; (11:6). If it slews, it will damage itself, and the fuselage. Similarly, as in 11:7, a steep cut-out at the leading edge will restrict the forward movement of a banded-on wing, so that in a nose-on contact with the ground, the wing or fuselage suffers. 11:8 is better.

When a dowel peg is used to locate a wing, it will allow the latter to slew under the rubber bands, but prevents it moving fore and aft. If the wing has ailerons or flaps near the centre section, these may be damaged : see 11:9. Installing the peg aft, in this case, as seen in 11:10, allows the front of the wing to slide instead.

In order to avoid the use of projecting dowels and large rubber bands in an otherwise clean airflow, the system shown in 11:11 was used on an electric aerobatic model. Wide nylon tape lies flat on the wing and passes down onto formers at leading and trailing edges. The ends terminate in wire hooks, over which a small band is wound to secure the wing tightly, but which will break in a hard landing. Two-piece wings may part under the wing bands, so apply vinyl tape to prevent this – (11:12).

The use of a 'dethermaliser' (a system to limit the flight time) requires a different method of fixing for the tailplane, or in the case of chuck gliders, the wing. In this case the leading edge of the wing lifts, to stall the model down. 11:13 shows a bolt aft and small rubber band at the front. A burning fuse (lamp wick) melts the band then snuffs itself out. Tip-up tailplanes are held by a band at the leading edge and a thin wire or nylon to the rear, as in 11:14. For twin fins, the glued-on end fin detail is a break-away fixing. Seen at 11:15. It depends on a soft replaceable strip of balsa. The hard balsa end rib does not tear away, provided balsa cement or PVA glue is used. The joint can be re-glued several times before the soft strip needs cleaning off and replacing.

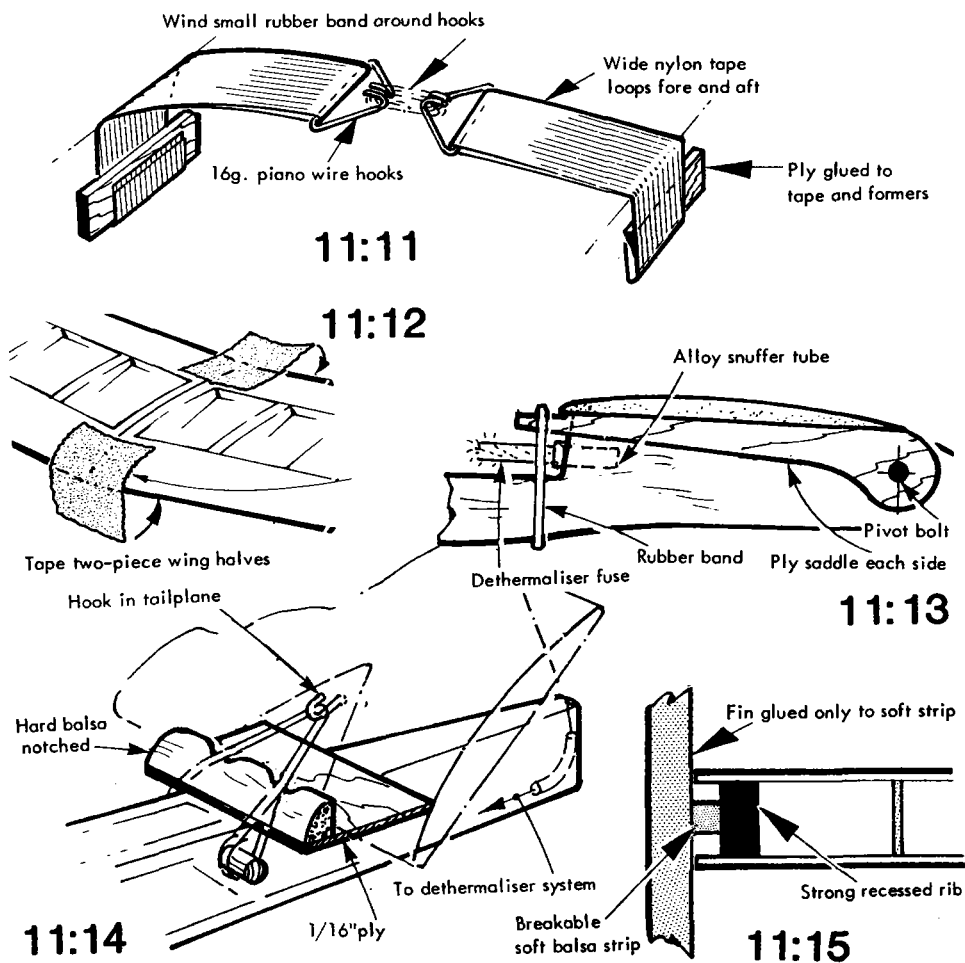

## Tongues and dowels

Wing halves can be joined by several means. The most rigid is the vertical steel tongue inserted into a close fitting brass box in each wing. The joint is flat, so unless there is space in each wing for the boxes to be tilted, the wing centre has to be flat also. If, however, the system employs a pair of boxes in the fuselage, and one in each wing; the boxes can be soldered together at an angle and one steel tongue used in each wing assembly. 11:16 shows a single flat wing version. Horizontal tongues, as seen in 11:17, do not provide the bending strength needed for high performance gliders, but suffice for small sport models. They can be made in balsa, in addition to the ply version shown. Note too, that whereas the steel tongue will bend to allow wings to knock back, the edges of these tongues have to be shaped as in 11:18.

Piano wire dowels in brass or alloy tubes serve a wide range of applications. The dowels can be bent to the dihedral angle and will flex to save the wing in a sharp stress condition (like pulling out of a dive suddenly). The wings can be held in place on the dowels by a transverse rubber band, as in 11:19, or provided with quick-detach 'buttons' as in 11:20.

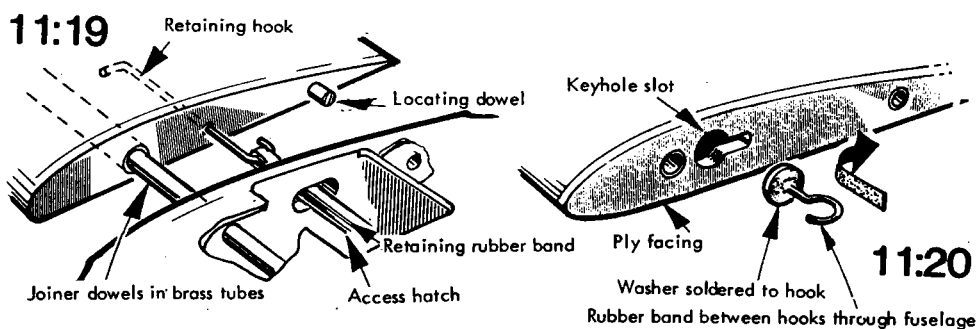
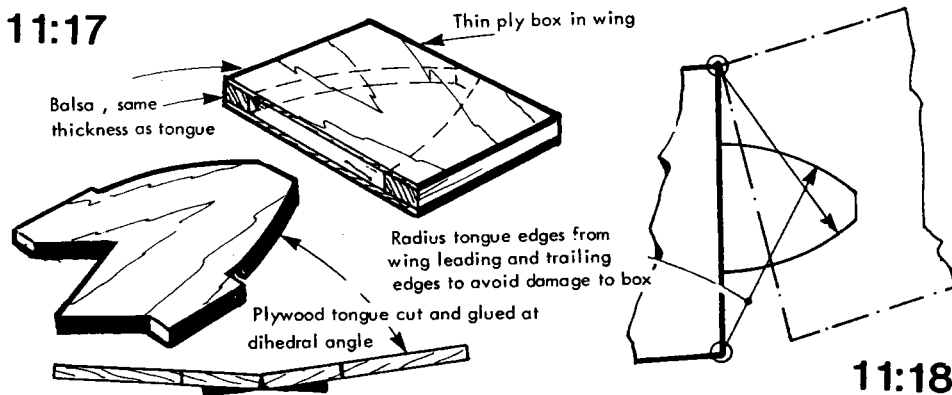
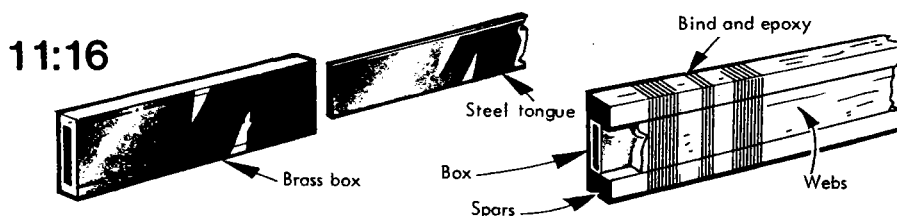



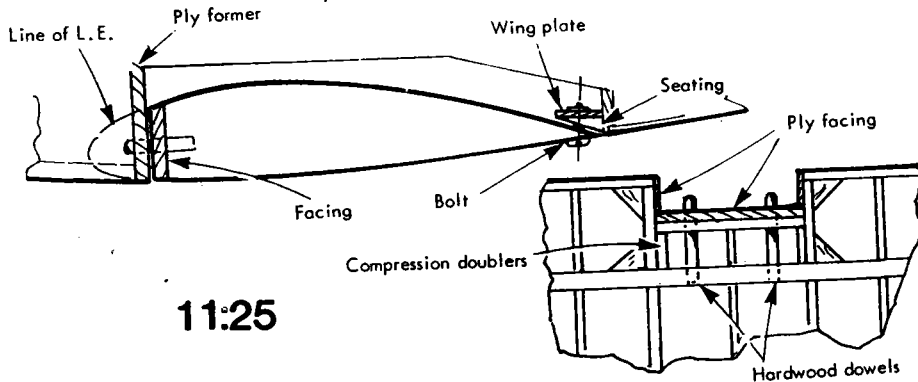
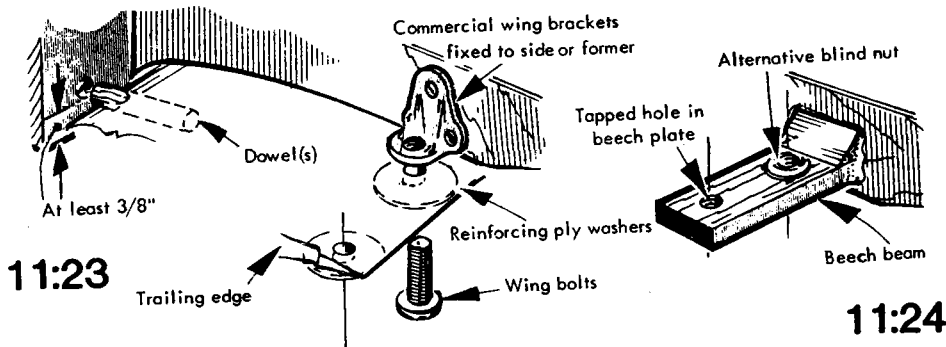
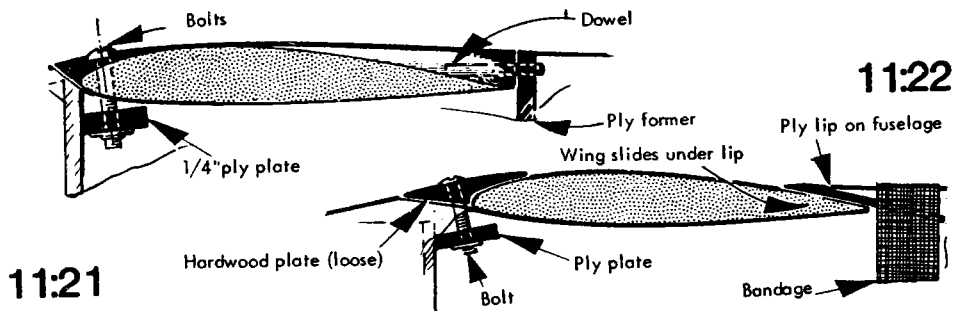

### Bolt-on wings

As might be expected, a bolt-on wing is less resilient, although if the bolts are thin enough, they will break before the wing or fuselage is damaged. The wing is firmly located and may be bolted at leading edge or, as is more popular, at the trailing edge. On a high wing layout, the front bolt allows the wing to ride forward in a 'sudden arrival', (11:21). It cannot slew unless it moves enough for the dowels to clear the rear former. Not so restricted is that seen at 11:22. Here, the wing wedges under a plate at the trailing edge and is restrained by a clamping block, forward. This wedges the wing firmly aft and down, but allows it to slew slightly, or to fall clear, should the 'arrival' break the bolt. It is important to make a secure job of the rear socket, using epoxy and tape or bandage.

The rear bolt system in 11:23 is typical, although the wing bolts may enter a hardwood or 1/4in. ply plate, as in 11:24. This is designed to pull out, rather than having the bolts break. Sometimes the fuselage formers dictate detail 11:25.

# CHAPTER 12

## Struts

### Cabane and centre section types

#### Wing struts

#### Fixings

#### Interplane struts

Unless a 'pylon' is used, wings mounted above the fuselage are carried on a set of struts, variously classed as 'cabane' or 'centre section struts'. If you prefer woodwork to wire bending, try that in sketch 12:1; the top rails are laid flat on the sides of the uprights, and a doubler piece forms an infill. Notches in the ends hold the wing retaining rubber bands.  $\frac{1}{8}$ in,  $\frac{3}{16}$ , or  $\frac{1}{4}$ in. ply can be used for the strut unit in 12:2, according to model size. The piano wire wing dowel is in one piece and must be bound or taped securely. 12:3 makes good practice for wire benders and needs soldering. 12:4 is more of an engineer's job; countersunk bolts may be used instead of pop rivets.

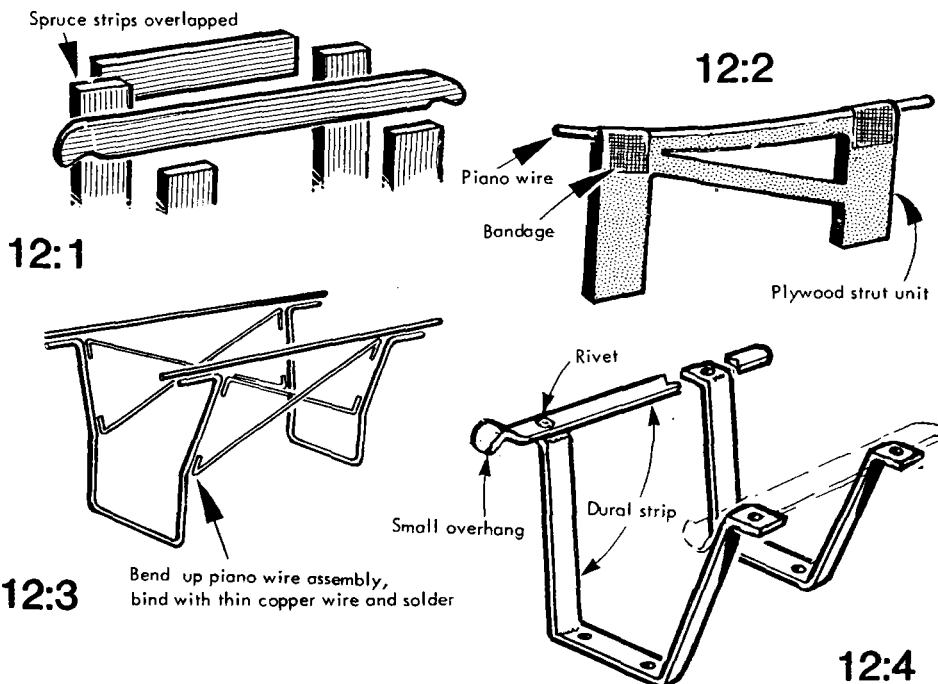

All these struts need a secure fixing in the fuselage. Vertical ones may look unrealistic, but if there is a longeron, see that the struts do not weaken it (12:5). Wire or strip metal types can be bound or screwed to strong cross bearers. When the wing is to be bolted in place, the strut ends can be drilled and blind nuts fitted to ply plates in the wing, as in sketch 12:6. Locking these plates to the spar and rib system is important. If foam wings are used (chapter 16) bolt right through, with nuts under the strut ends.

Strut-equipped high wing models usually have a strong one-piece wing, so the struts are dummy and can be lightly attached with rubber bands or hooks and loops. A typical strut appears in 12:7. The ends locate on open hooks and the little jury struts are sprung into place or banded on. Sometimes a rubber band forms the jury strut itself (if the model has them).

Other dummy struts can be held to the fuselage by a rubber band through a tube or underneath. The outer ends can spring into loops or tubes. 12:8 shows a soldered loop of a firmer bolt-on version and 12:9 a simple loop for the wing made from a split pin. These may be used on the fuselage as well.

Whatever the type of removable or knock-off fitting, the fixing points should have a small piece of  $\frac{1}{32}$ in. ply or hard  $\frac{1}{16}$ in. sheet let in flush around the fitting, otherwise the strut may damage the surface, or poke through the covering.

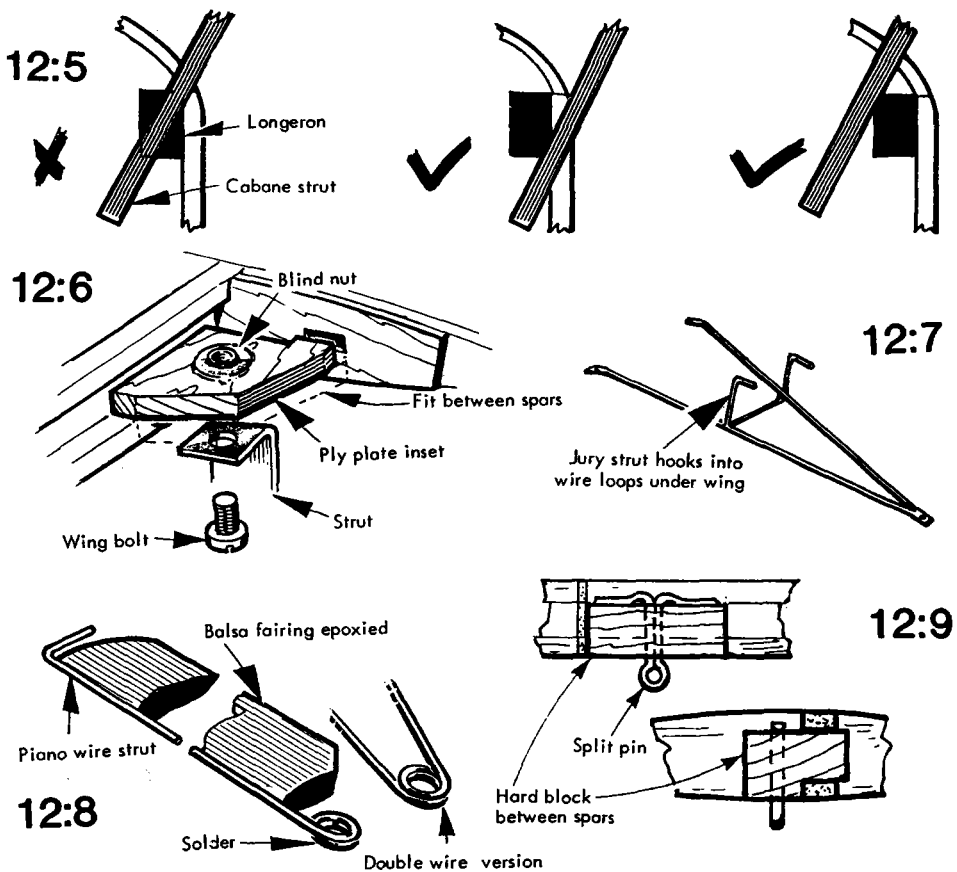

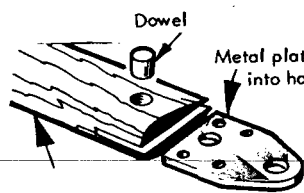

12:10

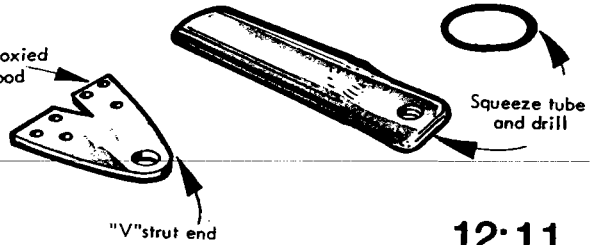

12:11

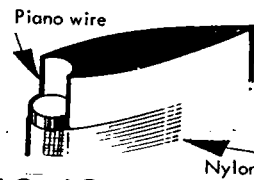

12:12

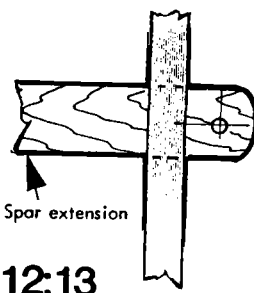
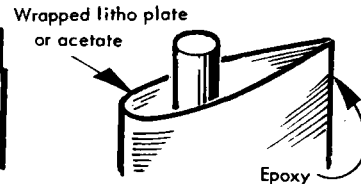
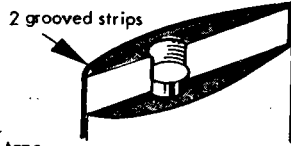

12:13

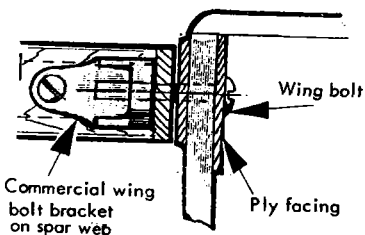
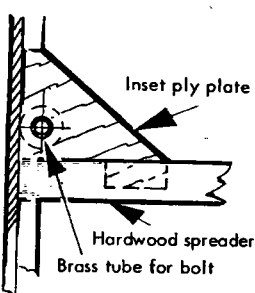

12:14

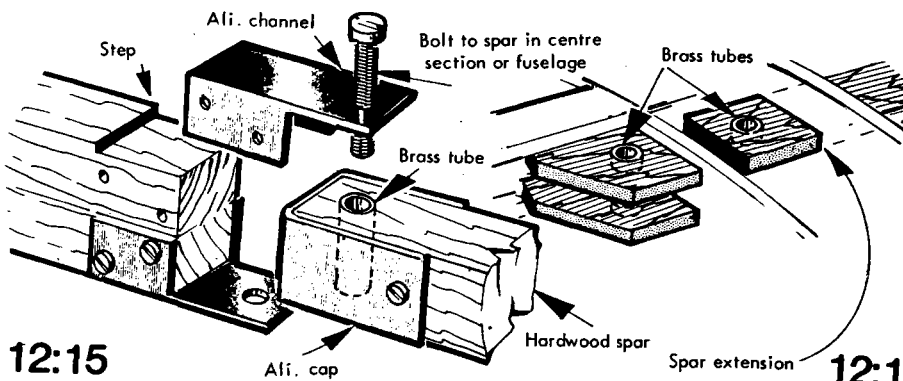

12:15

12:16

Spruce struts may be strong enough without piano wire, but they need fixing plates which should be really secure, as shown in 12:10. Alternatively, alloy tube can be squeezed to form slim struts as in 12:11 and teardrop section streamline alloy tube is available in model shops.

Large fairings can be added to piano wire struts in several ways . . . see sketch 12:12. The two-piece version (central) is the neatest method, but a carefully joined piece of litho plate, thin ABS sheet or thin card can be effective, permitting the wire to flex under stress, without cracking the fairing. Sketch 12:13 shows how to fix the roots of wings which rely structurally on struts. That in 12:14 needs an access hatch in the fuselage. Those in 12:15 and 12:16 rely on shear bolts (large and small models).

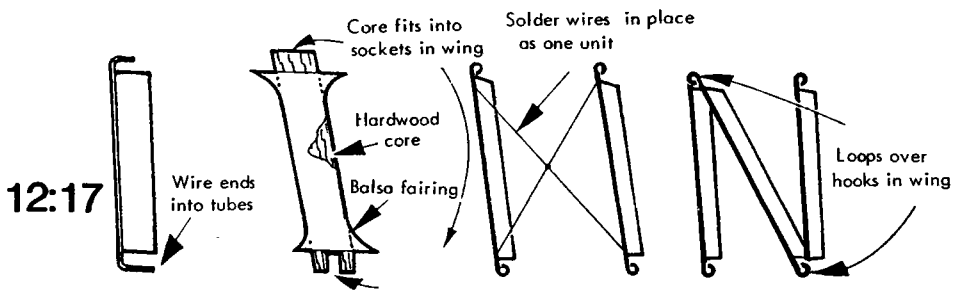

12:17

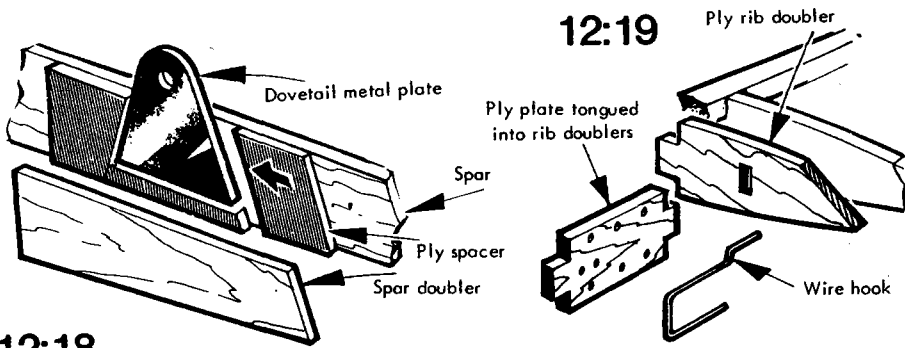

12:18

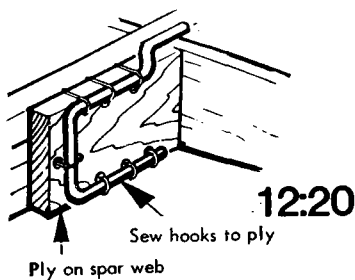

12:20

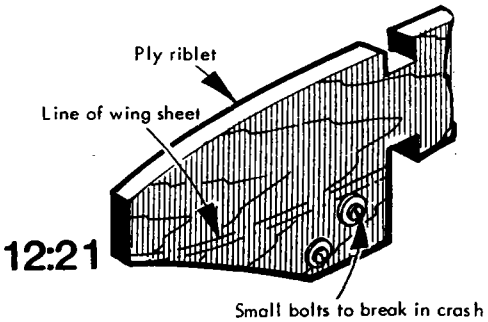

12:21

**Interplane struts**

Much of the foregoing end details apply here, but the sketches in the 12:17 group show some applications and arrangement of wire work. Where there is interplane rigging, it may be used to hold the struts in place, facing the hooks outward on the wings or inwards on the struts. Dummy rigging can be made from shirring elastic, or, on larger models, wire fishing trace tensioned with rubber bands. Working rigging is more fully described in books on scale modelling.

Sketch 12:18 shows a dovetailed fixing plate in the wing, 12:19 the method of installing a ply plate to carry a strut hook, for use where there is a risk of rough treatment. The piano wire hook could be 20-18s.w.g. and bound or sewn, and epoxied to the ply, as in 12:20. On small models, the hook can be bound directly to a spar. External lugs can be part of a ply riblet, as in 12:21, but the skin needs support each side, the covering fabric or tissue being stuck to a cap strip each side.

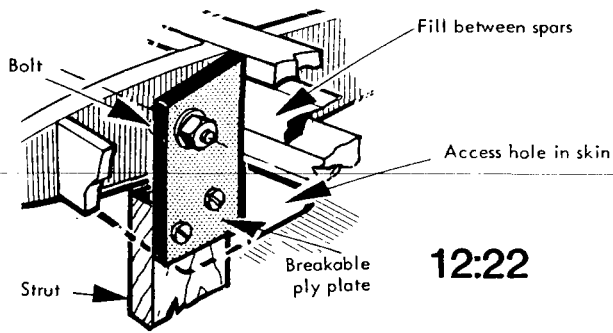

A smaller external lug is detailed in 12:22 and is steadied by the spars, but an area of sheet will be needed around it with a cut-out to gain access to the bolt which fixes it to the rib. The same detail could be applied to the fixing of a wing directly to centre section struts.

The more pieces of struttery and wing fixings one devises, the more complex some of them seem. Once you have selected a system that suits your particular model, stick to it, there's no sense in being different, when it is already reliable.

# CHAPTER 13

## Landing gear

- Springing, main legs
- Nosewheel legs
- Wheel retention
- Tailwheels
- Skids
- Dollies
- Retracts
- Wirework

How many wheels? A two-wheel landing gear (undercarriage) is sometimes referred to as a 'tail dragger' – the tail end having to make do with a skid or small wheel. Such models require more care on take-off, particularly if the main wheels are far forward of the centre of gravity. If they are moved back, the model may tip up on landing, for ground friction is greater in proportion on models, compared with full-size aircraft. The tricycle layout is more stable, but benefits from the nosewheel being steerable. Single leg and more rarely tandem wheels are mainly chosen for free flight, or control-line racers. Indeed, most free flight models tend to be hand launched, so a nose skid may suffice. Sketch 13:1 shows some planforms. When a model lands, the

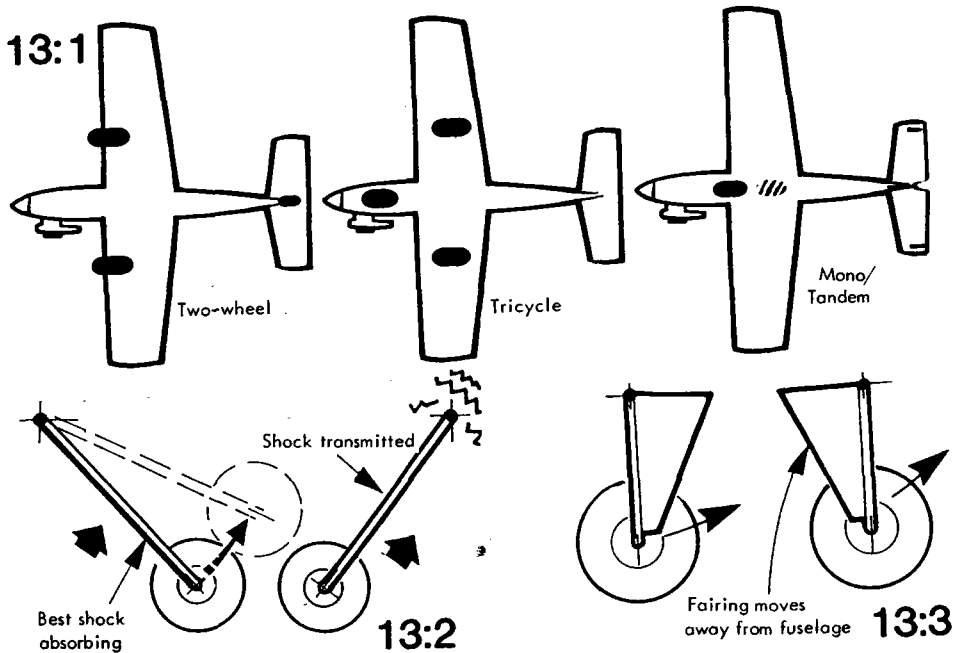

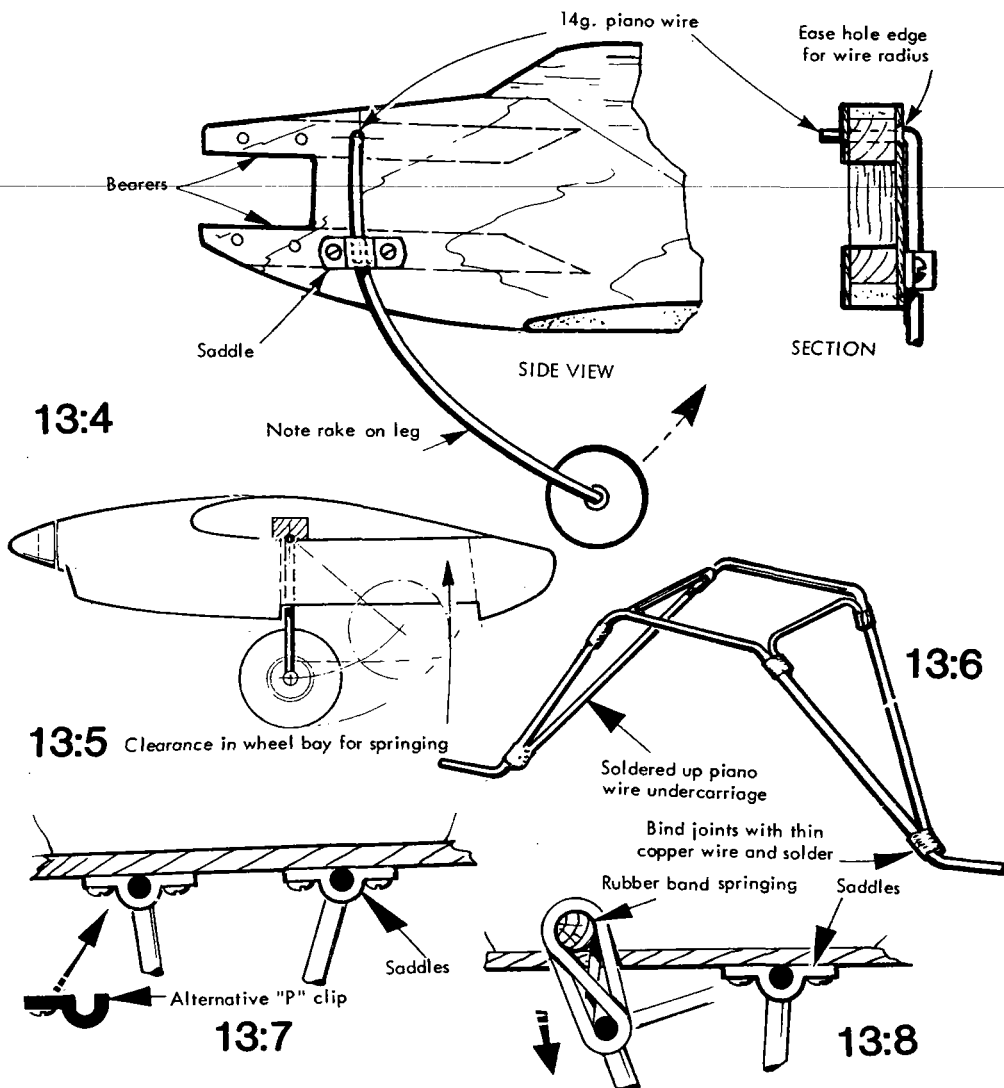

leg(s) tend to knock back and up, rather than straight up, as in full size practice (it's that ground drag again) – 13:2 explains. A leg fairing is safer in front, if the leg is to bend back (13:3) otherwise it crunches into the fuselage.

### Simplicity

The simple leg on a profile Goodyear control line racer is a good example. If it were straight, the jar of setting down in the excitement of a race could wreck the model. 13:4 shows how to fix it. A dummy retract can be sprung to go back into the wheel bay of a twin, or even single engined C/L model (or R/C for that matter) (13:5). Basic wire two-wheel undercarriages are a good test of handiwork with wire and soldering, see 13:6. If you are not sure, make one in coat hanger wire, to get the lengths and angles right before using piano wire for the proper one. Commercial nylon saddles hold wire parts to a ply plate under the model; 13:7 (the 'P' clips spring away or break in a hard landing. Rubber bands will also provide springing (13:8)).



Leaf undercarriages are a wide strip of dural (aluminium is too soft). Commercially available or home-made, they must have high tensile steel bolts for the axles (or these would break), see 13:9. Small models can have the leaf bolted to a fixed ply plate as in 13:10, but rubber bands provide a safer attachment, in that the U/C will tear off cleanly on rough ground. (13:11).

If you are determined to use bolts, try fitting rubber grommets to absorb some shocks and to tear out, leaving the bolts in the model (13:12).

Some free flight models have plug-in legs and 13:13 explains how to get plenty of bearing length in the tubes. Torsion bar springing is simple and neat – see 13:14, which is for fuselage-mounted types. Wing mounted legs (low wings) are shown in 13:15 with variations in 13:16 for lighter models and 13:17 for a one piece beam.

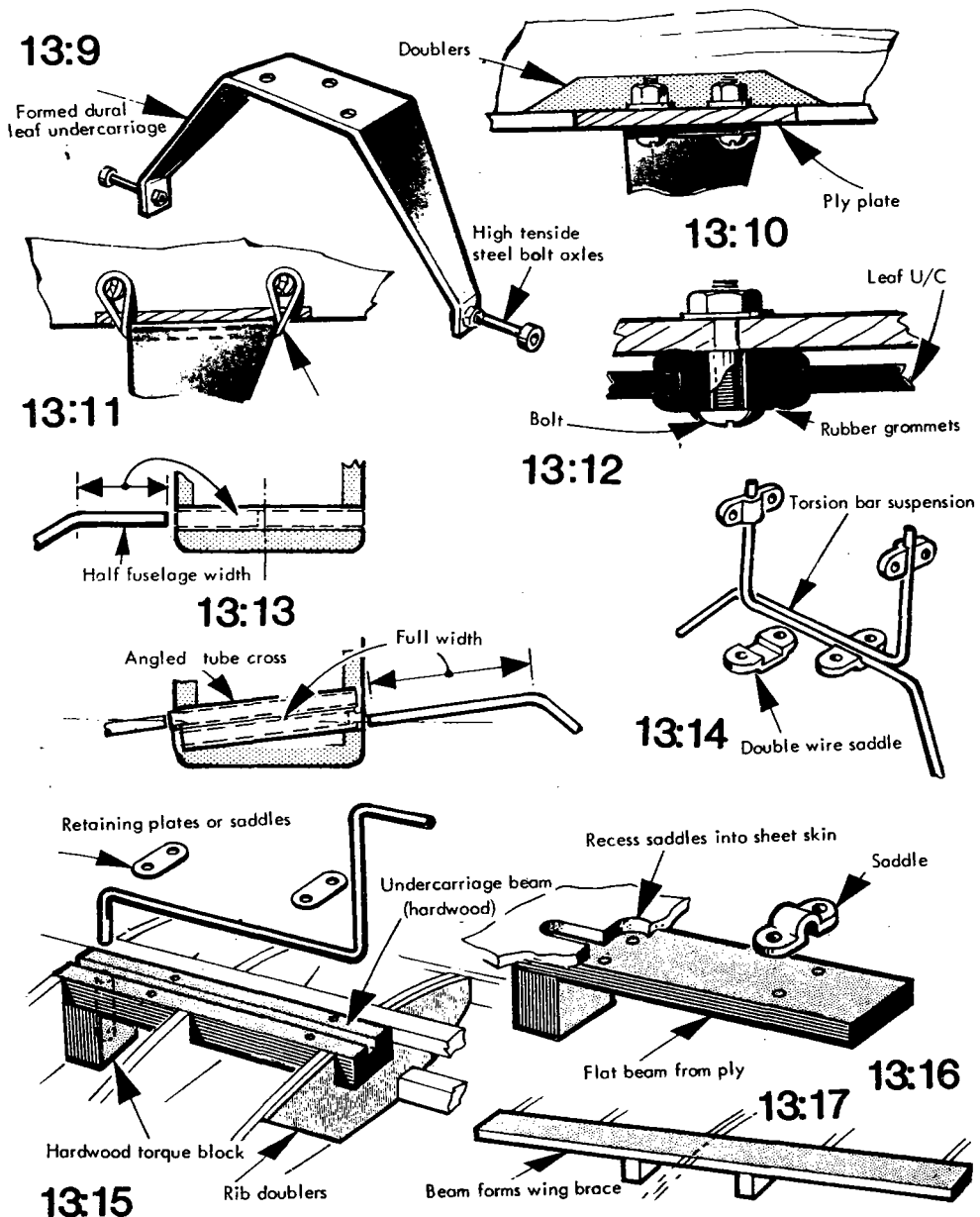

## Noselegs

The noseleg comes in for much punishment and is readily knocked back. A coil formed in the wire provides springing, but it needs support nearby, see 13:18. Twin legs can be sprung by torsion bars, (13:19). Steerable legs are shown in 13:20 which is home-made, or an elaborate commercial one for heavy models in 13:21.

A convenient point of attachment is the engine bulkhead; some radial mounts are already grooved (13:22), otherwise add ply spacers and a bearing tube as in 13:23. Wheels will not turn smoothly on the axles if they run up onto the leg bend. See 13:24. A collet with socket or Allen setscrew will retain the wheel, but file a notch in the axle for it to grip. If the tip of the axle is annealed, a thread may be cut on it with a screwcutting die. Cap nuts make a neat job, as in 13:25, but use thread locking compound.

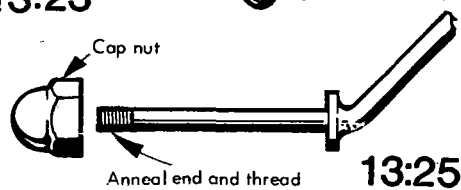
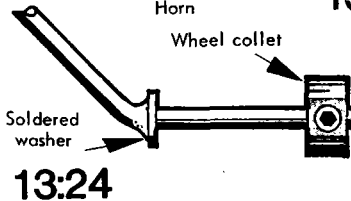
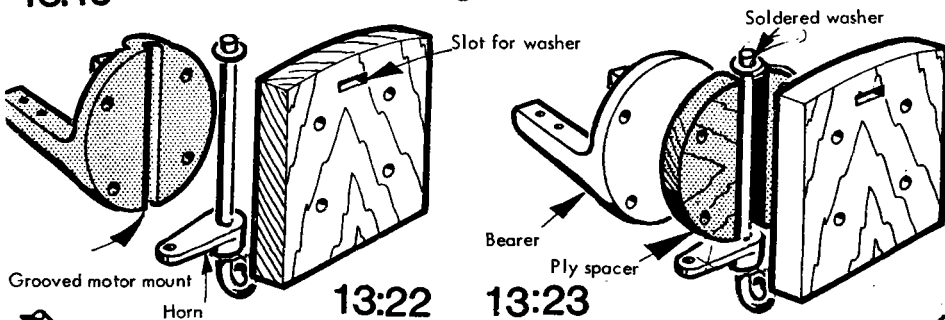
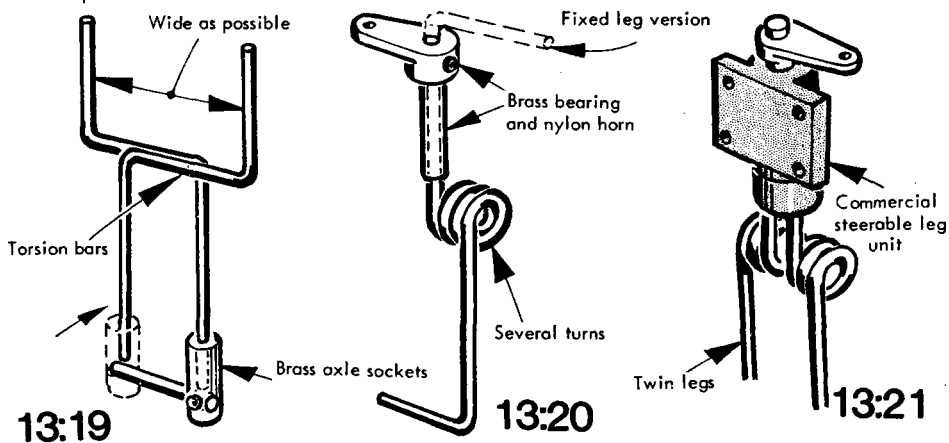
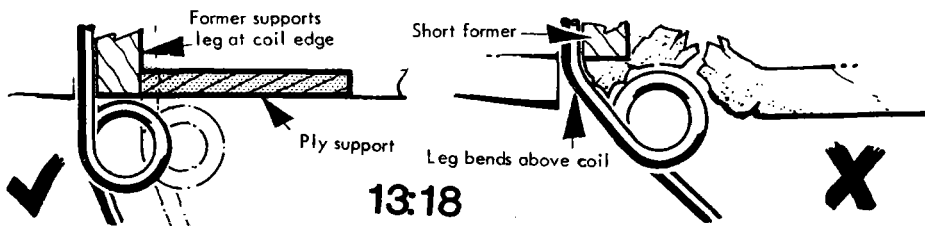

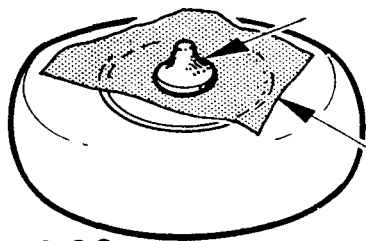

13:26

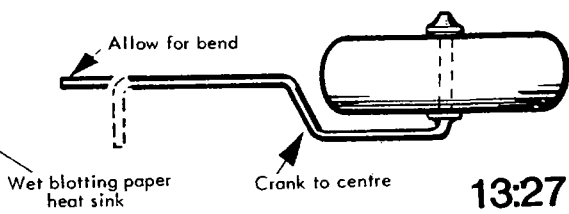

13:27

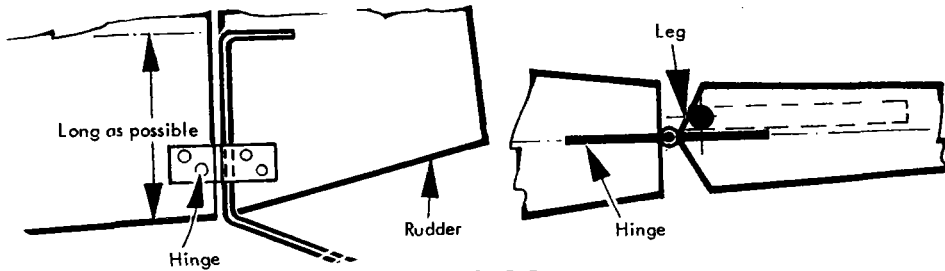

13:28

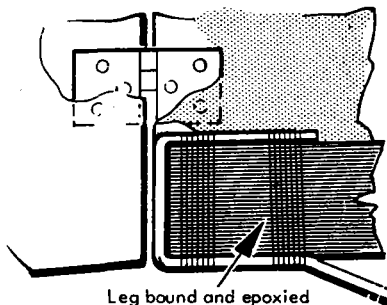

13:29

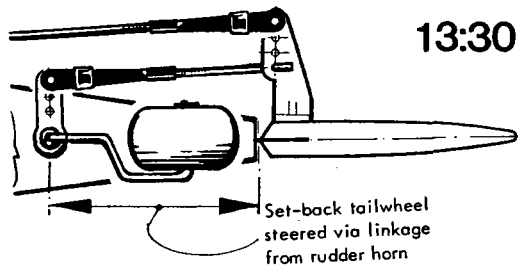

13:30

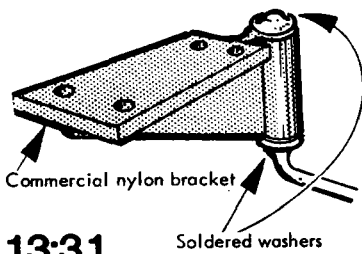

13:31

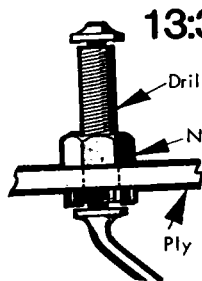

13:32

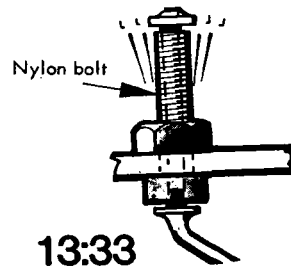

13:33

A washer can be soldered on to retain a wheel, but in order to avoid softening a plastic hub, follow sketch 13:26. Tailwheel legs are cranked to position the wheel in line with the centre of the fuselage (important if they are to castor and neat otherwise). (13:27). When the leg is fixed to the rudder, as in 13:28, the model may be steered as it taxis tail down. If the wire is short, reinforce the rudder (13:29). The tailwheel can be remote from the rudder, but driven as in 13:30. Freely castoring wheels can pivot in a commercial bracket (13:31), or in a drilled bolt, as in 13:32. Nylon bolts afford springing (13:33).

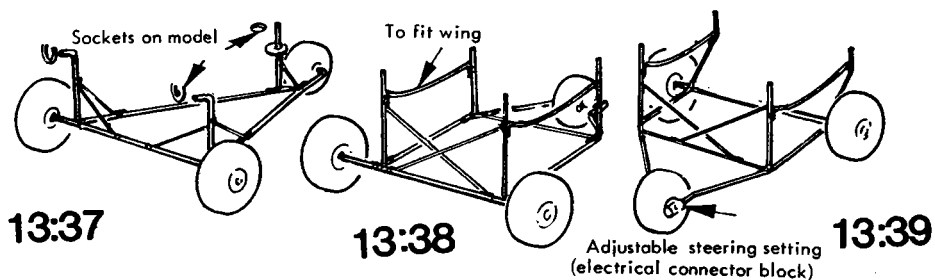
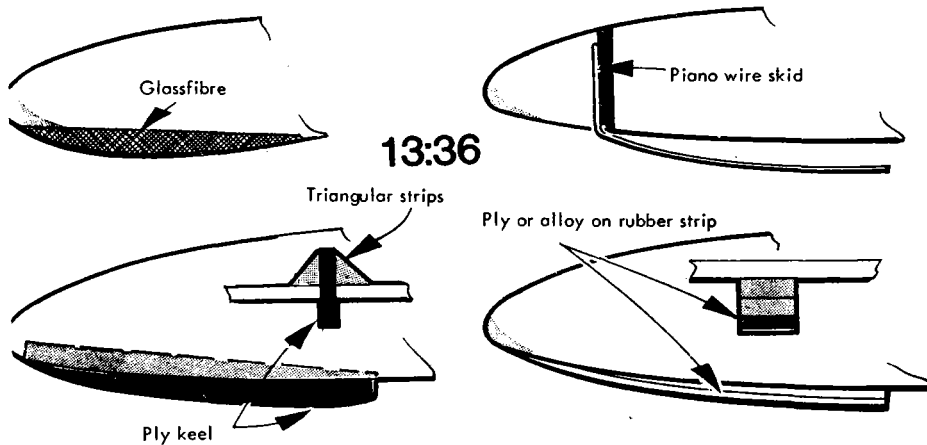
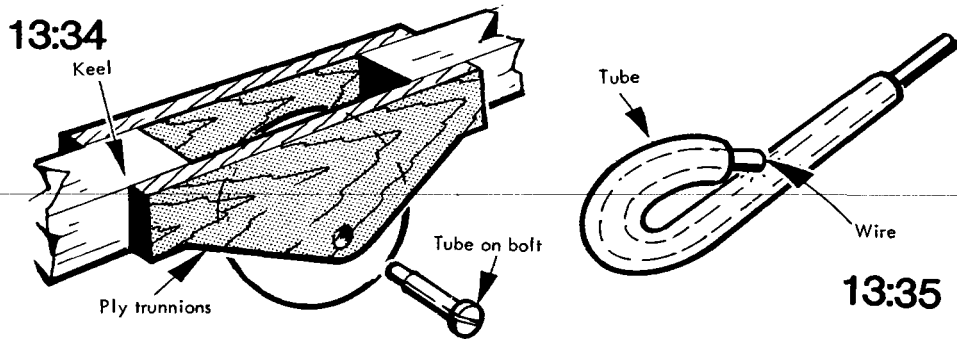

A glider may have a landing wheel mounted on trunnions as in 13:34 – fine for the big ‘uns. The tailskid that screeches along a runway should be banned! Full-size aircraft with skids are supposed to land on grass. Try 13:35.

The nose of a glider is a skid too, whether it is just reinforced or fitted with a rigid or sprung skid – choose from 13:36.

Suppose there is no undercarriage . . . Control-line speed models, and some scale subjects flown in ‘retract’ mode (no wheels), need a launching dolly, as in 13:37, which needs the tail to rise to free it, or 13:38, where the model is unrestrained. 13:39 suggests a means of adjusting the tracking, so that the model runs straight if radio controlled, or without dragging the lines or running-in, on a control-line circuit.

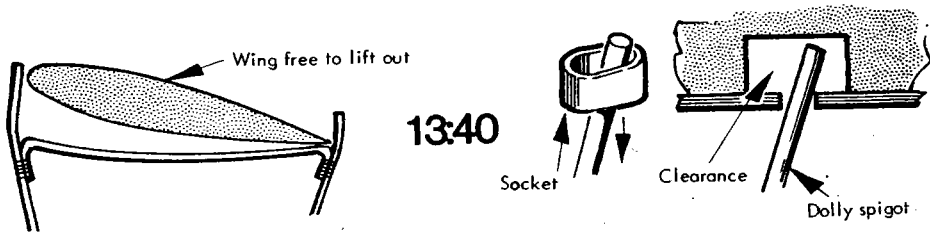

13:40

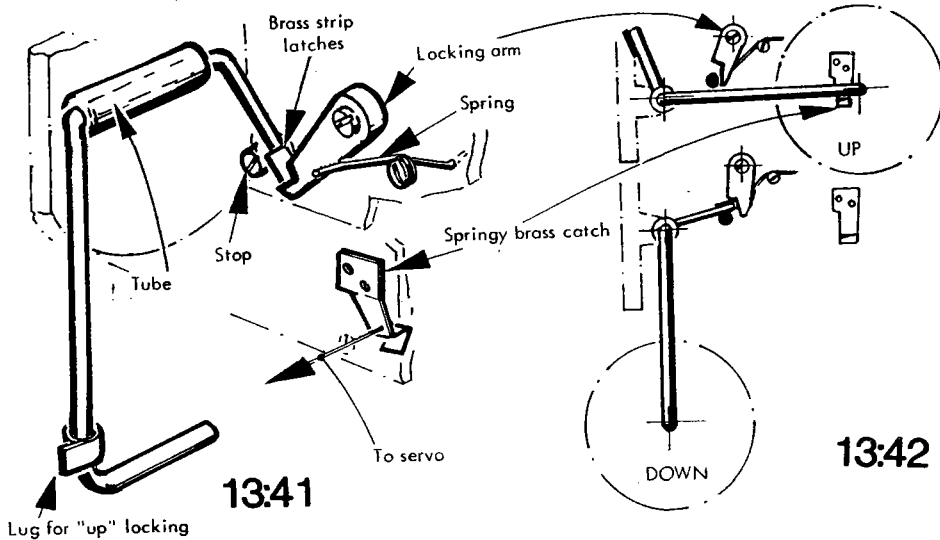

13:41

13:42

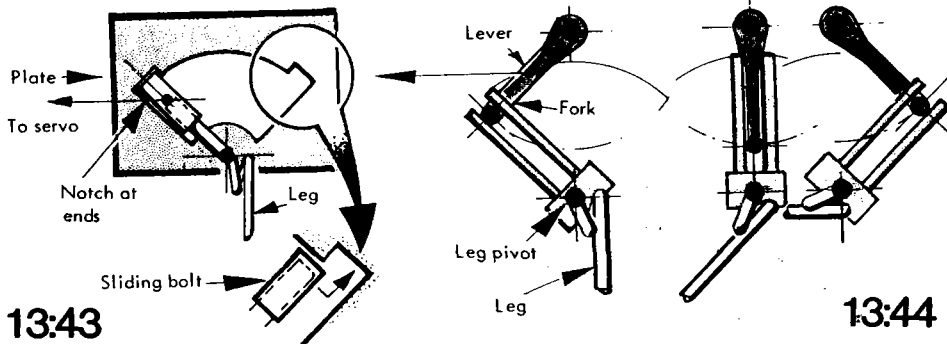

13:43

13:44

It is important that the model frees itself cleanly from the dolly, so those retaining prongs must be long enough to prevent the model bouncing out early, yet shaped to clear without carting the whole thing way up in the air. 13:40 also shows a socket in the model which should not jam when it is tilted.

### Retracts

Let's start easily. A hand-launched scale model can have realism by lowering the undercarriage in flight. No servo is needed, because the throttle servo can be linked to unlatch it. When dropped, it locks down. 13:41 shows the construction, 13:42 the action.

Commercially available (or some home-built) retract units are seen in 13:43, which bolts the leg up or down, while that in 13:44 uses a slotted arm or fork and goes over centre in each direction.

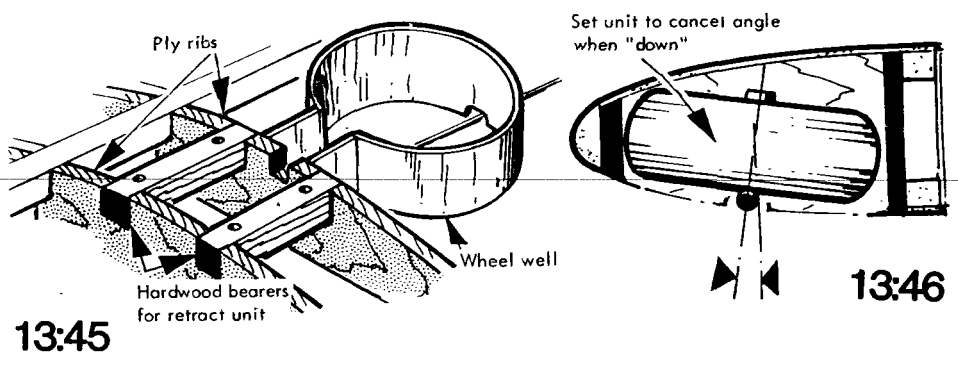

13:45

13:46

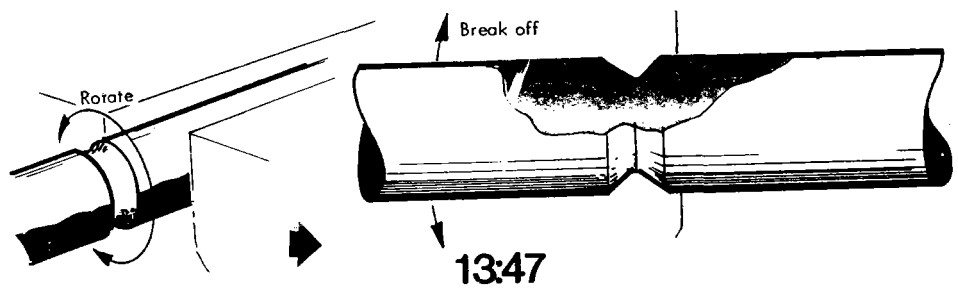

13:47

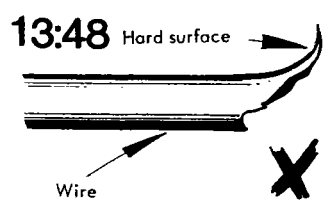

13:48

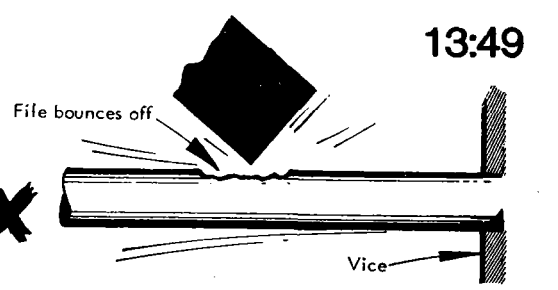

13:49

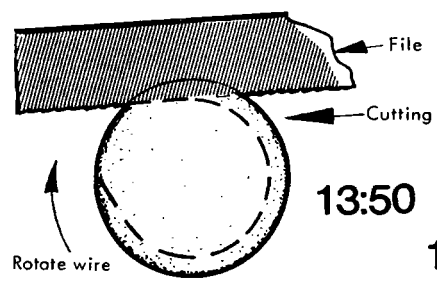

13:50

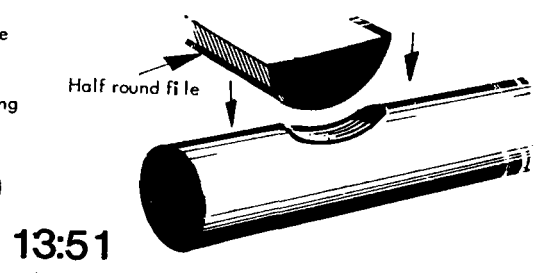

13:51

A typical installation is seen in 13:45. Individual units require slightly different beam positions. It is important to make the smallest possible cut-outs in the structure, for although the legs of the units are sprung, there is a twisting load on the wing. Geometry is important too; 13:46 shows that a wheel may have to be angled in the 'up' position, which means turning the mounting beams too.

It would be difficult to go far in aeromodelling without practising wire work. What follows should help; mostly self-explanatory, these sketches, but . . . 13:47 shows the ideal cutting method for piano wire, 13:48 is what happens in haste and 13:49 reminds you to clamp close. Piano wire has a hard surface and cut should be from softer to harder, 13:50 explaining why the wire is turned. Setscrew flats should not reach the wire end (13:51).

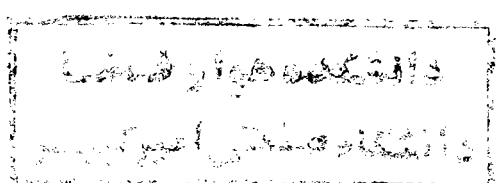

A flat file gives more of a grubscrew restraining shoulder (13:52). A grindstone serves too, but suffers with use as in 13:53. Always wear eye protection when grinding (13:54). Do not try to cut thick piano wire in pliers, use large enough pliers when bending and press the wire on a hard surface too, (13:55). If a tube has to be positioned between bends, follow 13:56, gently re-shaping the tube afterwards. The dotted lines show the positions of the pliers as the job proceeds.

So many people clamp the wire in the vice and wrestle it into a sharp bend – 13:57 is a better way.

Thin wire (up to 16s.w.g.) can be bent in a home-made hole jig, as

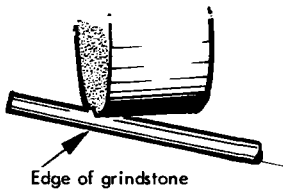
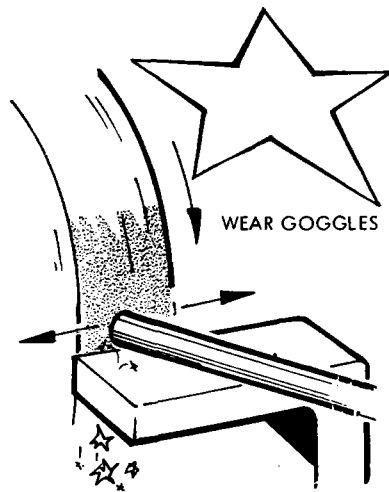
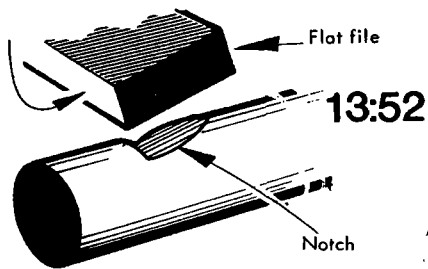

13:53

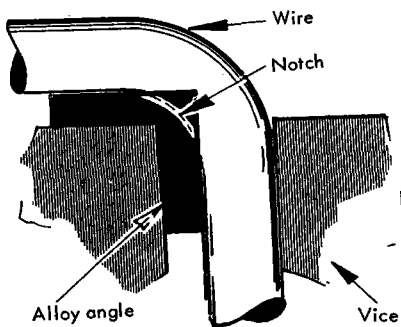
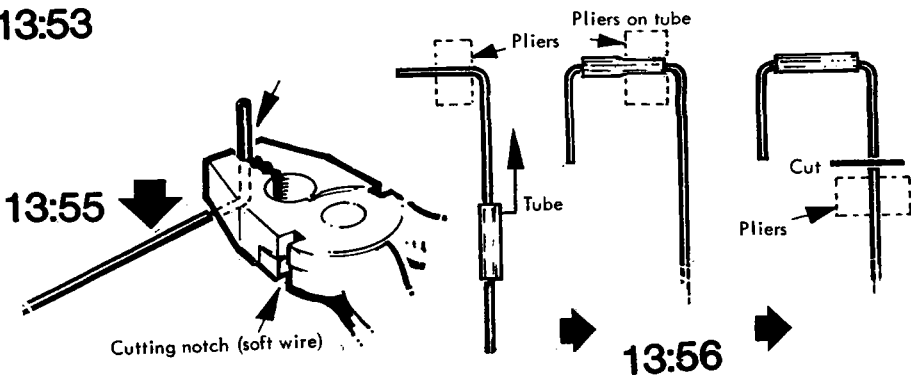

13:57

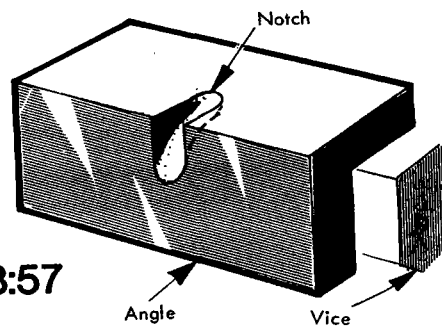

seen in 13:58. A second piece of steel bar rests on the wire and is hammered down. This gives a nice straight length each side of the bend. Sketch 13:59 shows that if wire is forced around too tight a radius, it will be weakened, even if it is annealed first. (Heat to red heat and work before or as it cools, re-heat and plunge it into water to restore some of the temper. Too much will make it brittle). Commercial wire benders will make short work of forming bends and coils in thick wire. 13:60 is a simple bend and 13:61 a coil, see how the bending arm rides up. When wire has to be epoxied into wood, it will benefit from a keyed surface; 13:62 suggests solder, 13:63 fuse wire soldered.

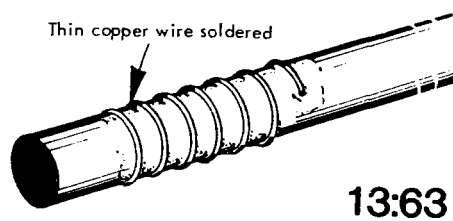
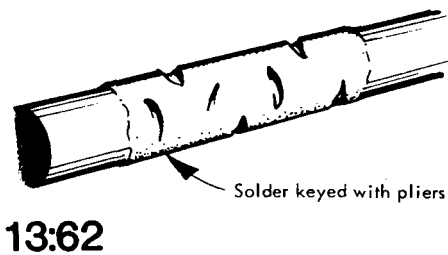
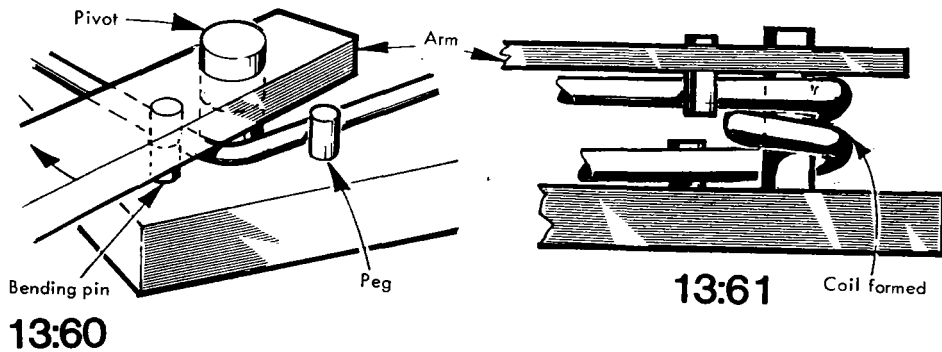
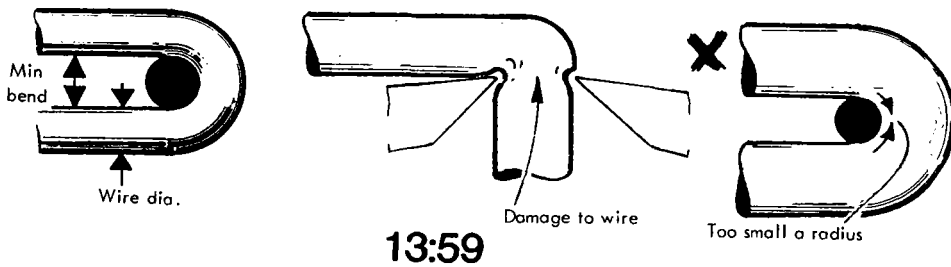
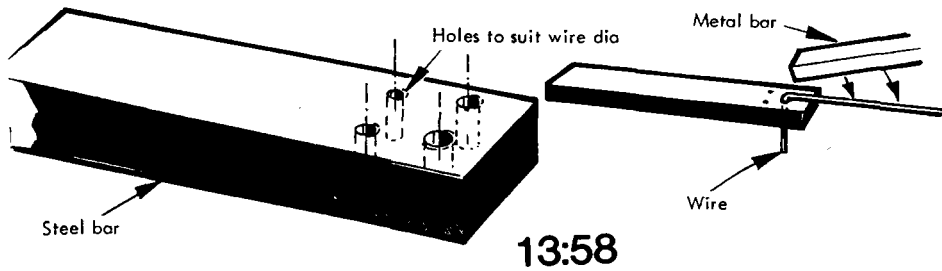



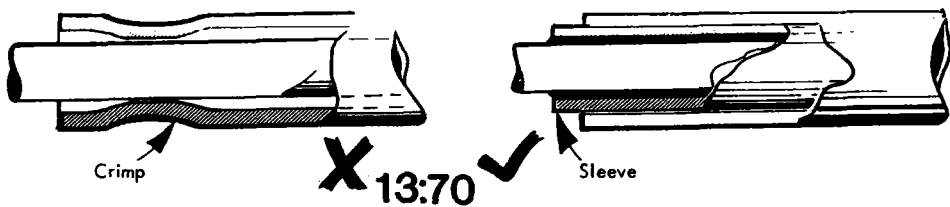
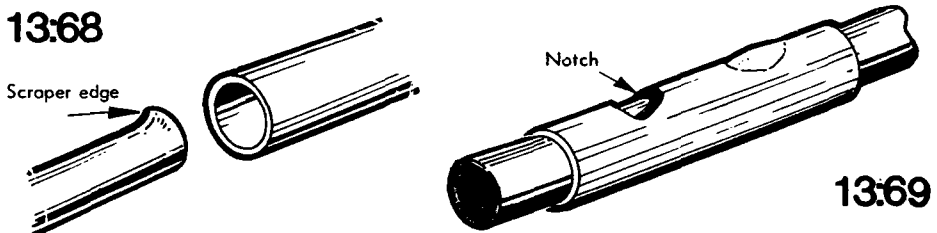
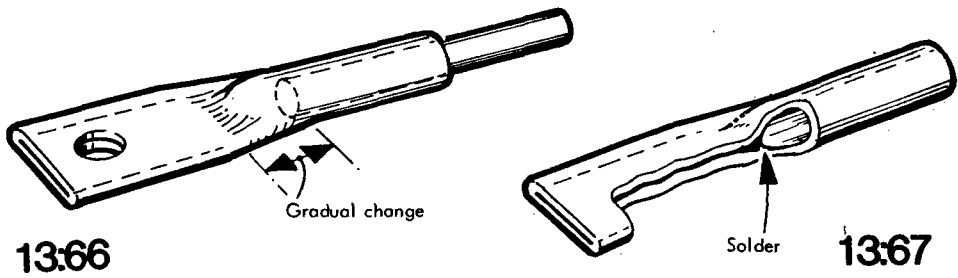
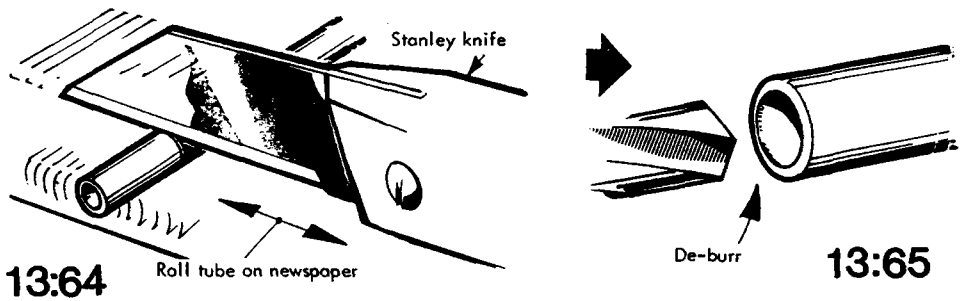

## Tubes

Thin wall brass, copper or alloy tubes are easily cut to length by rolling as in 13:64. Keep the knife in the groove it cuts. A burr will be left inside (13:65). Wire ends can be given drilled lugs as in 13:66 – use this for horns, struts, and linkages. To solder it, apply solder paint inside (13:67).

The inside of the tube may not be clean enough for this as bought, so bend piano wire and grind or file it to make the scraper in 13:68. A notch in the tube also keys and aids solder flow (13:69).

Never put up with sloppy fits: crimping is not the answer, as it will soon wear loose again-see 13:70.

13:71

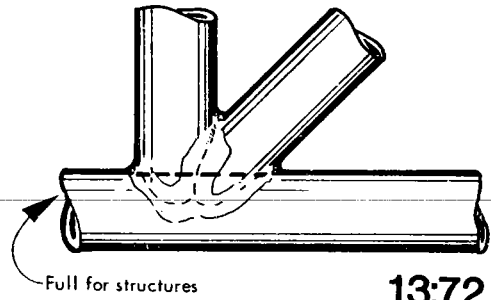
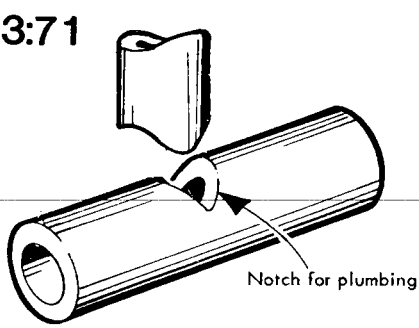

13:72

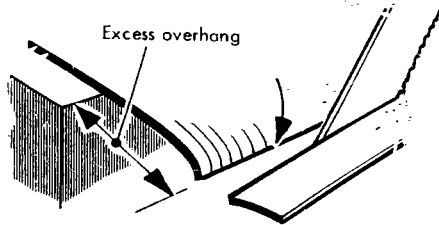

13:73

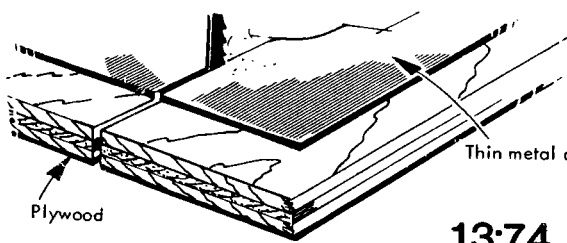
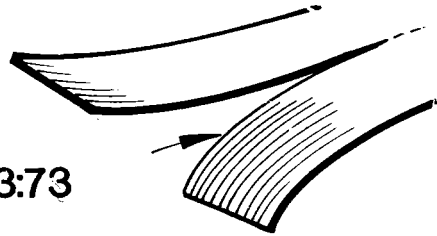

13:74

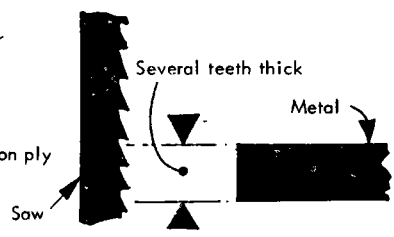

13:75

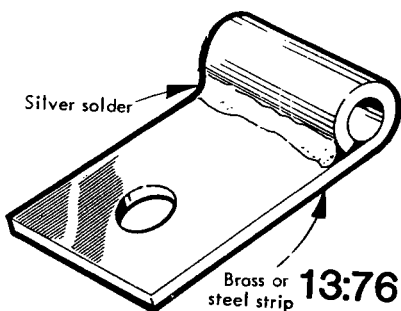
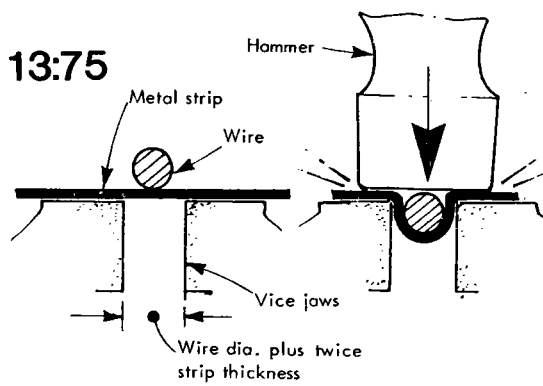

13:76

If the tube work is to be used in the fuel plumbing, remember to align the cut-out in one tube with the end of the one joining it (13:71). A piece of rusty wire locates it and won't bond to the solder. Retain the strength of a main tube in sketch 13:72 – file the others to fit and use nails in a wood block to align the parts.

Sheet metal will bend, stretch and buckle if it is not supported when sawn (13:73). Cutting with metal shears distorts it in long lengths, so cut thin metal by tack-gluing it to plywood and fretsawing with a fine metal cutting blade (13:74).

Saddles? Easy: look at 13:75, it's quick. Lugs like 13:76 open out if soft soldered.

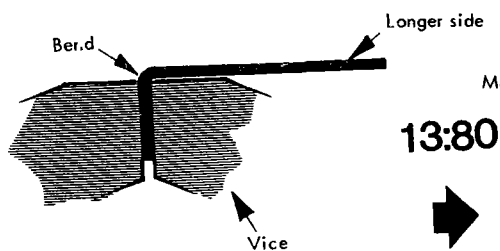
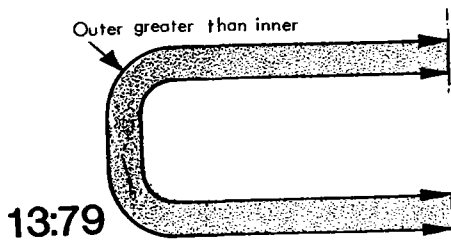
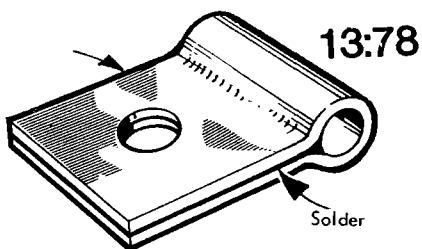
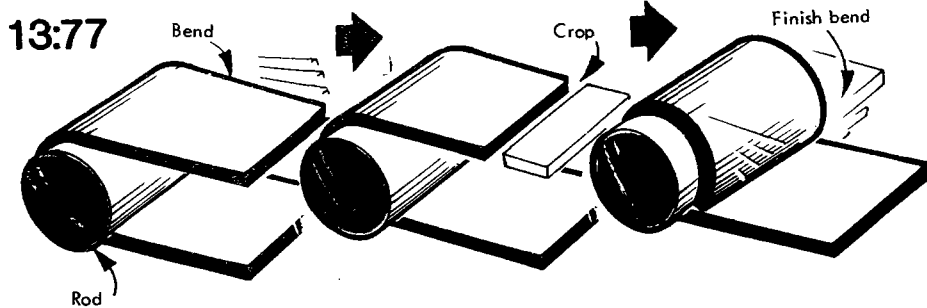

13:80

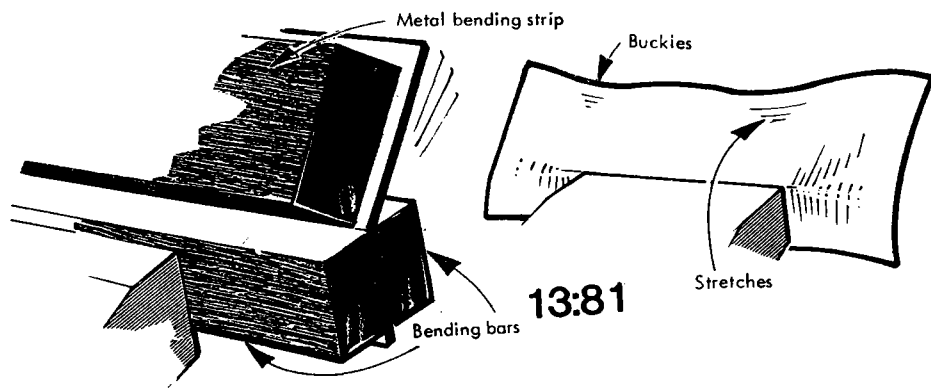
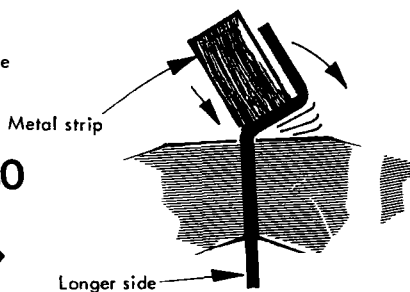

13:81

If you must make them like this study 13:77 to get the bend tight. 13:78 shows a more foolproof version, using thinner metal (plumbers' solder is O.K.). Why put in sketch 13:79? Thick metal will not bend to the same finished length as a thin cardboard pattern. Cut a very narrow strip and bend it first to test the measurements. 13:80 shows how to deal with sheet metal in the width of the vice. If it is wider, use strong rectangular metal bending bars (as seen in sketch 13:81. . . . Now you can go on a real 'bender'!

# CHAPTER 14

## Snow and water

- Skis
- Floats
- Flying boat hulls
- Wheel pants and spats

Extend the flying time of your sport model by equipping it for the winter snows . . . a two legged undercarriage can be modified to carry skis by removing the wheels as in 14:1. A little experiment may be needed to get the ski angle right, so that it does not prevent the model rotating for take-off (short skis are better). The limit wires or rubber bands should be tight enough to hold the skis at the correct angle for landing if the model is free-flight. Chop the rear ends of the skis back until the model almost puts its tail down.

14:2 is an alternative construction with square spruce on the centre line. The wheel collet and inboard washer (or two collets) keep the ski square.

14:3 shows a centre piece from aluminium channel.

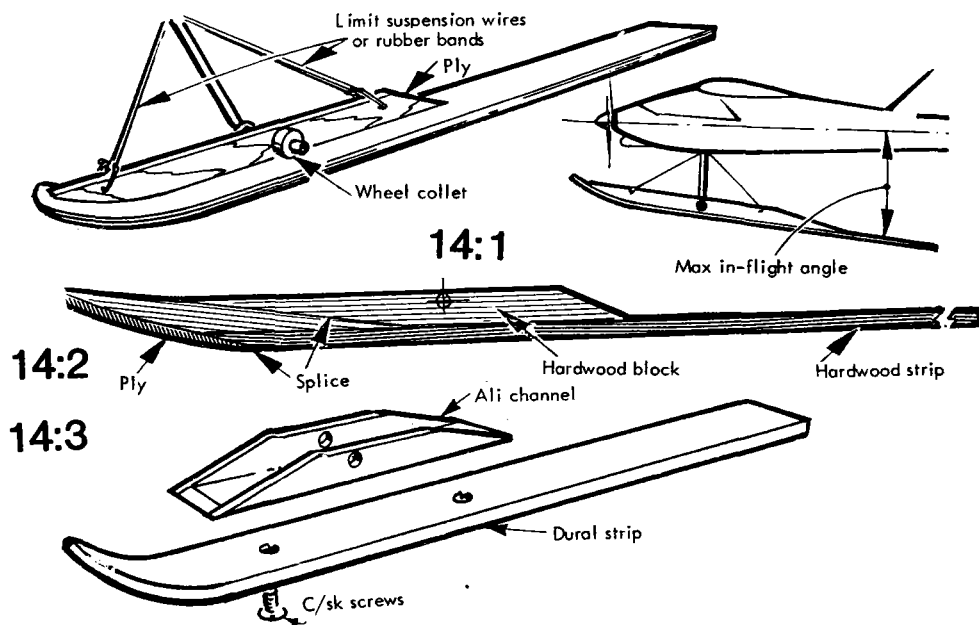

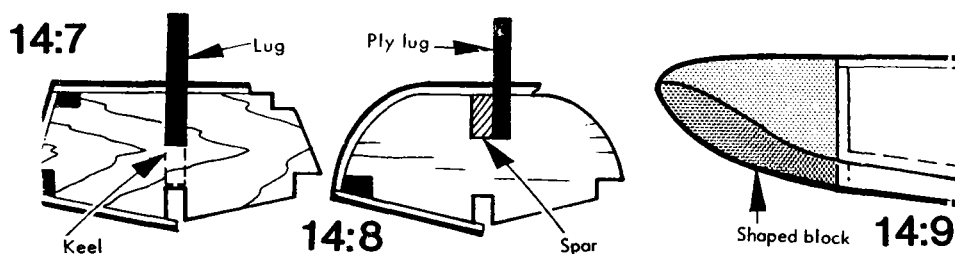
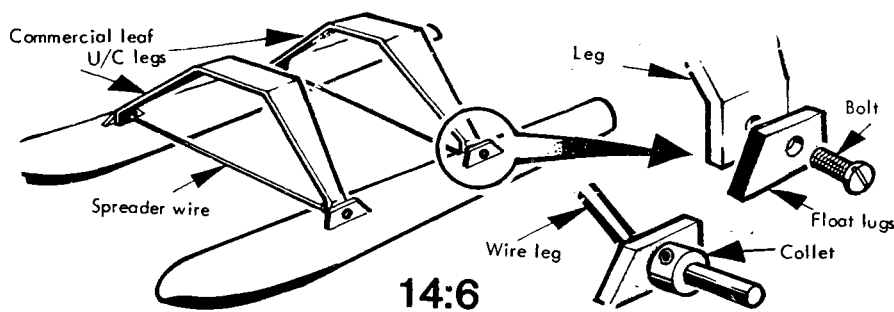
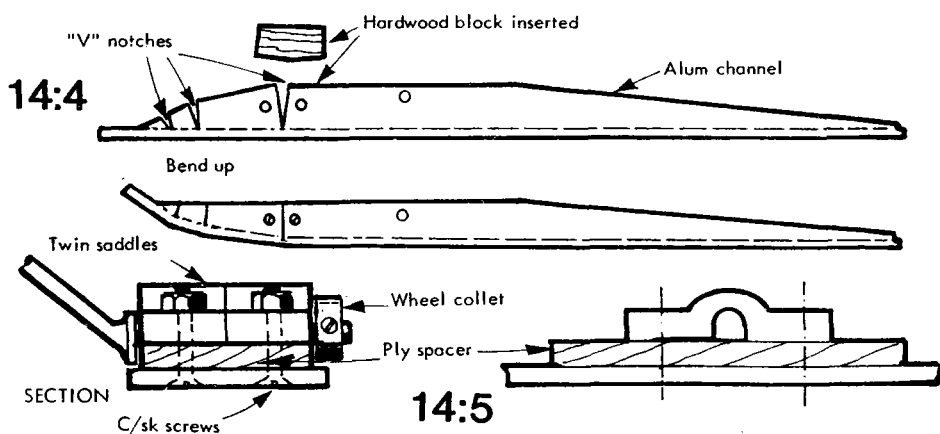

A larger section channel makes a box-like ski, when notched and joined as seen in 14:4. Two nylon saddles can be used as mounts, but ply will keep the collet off the snow (less drag) see 14:5.

### Splash!

A selection of commercial floats cater for floatplanes for R/C. A standard landplane can be converted by adding a second pair of legs aft, as in 14:6. Wire or 'leaf' system may be adapted to most flat-bottomed fuselages.

Home-made floats may be needed to suit models of smaller size. 14:7 shows how a mounting lug can be part of the keel, 14:8 is built with a separate lug and 14:9 details a typical bow. Use waterproof adhesives on all these examples.

Small free-flight power models can carry little floats as seen in sketch 14:10. The wing loading is usually so light that the model hops off easily and needs little buoyancy when at rest. It may be necessary to adjust the angles of the floats for best results, so, in view of the light construction used, have a truly vertical section of leg to be gripped in

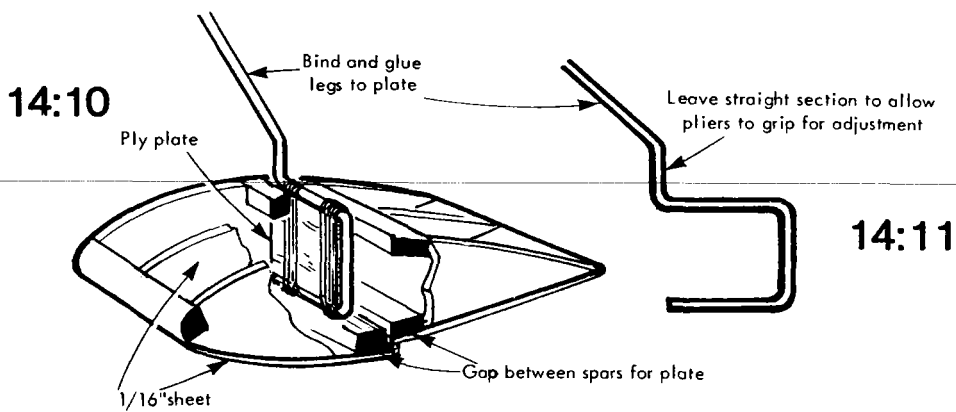

Leave straight section to allow pliers to grip for adjustment

14:11

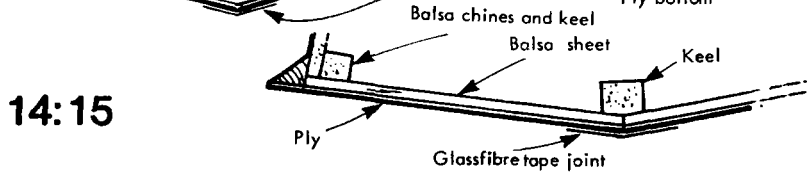
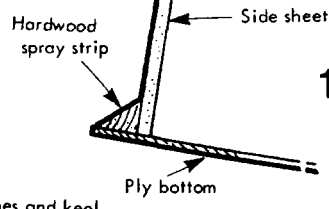
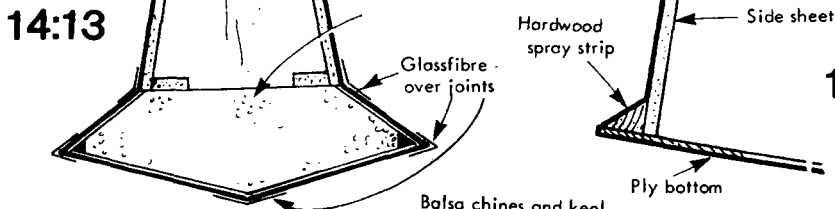
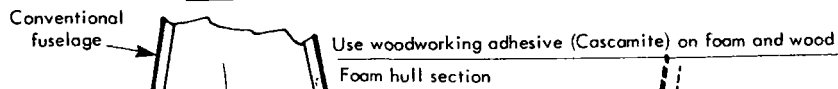
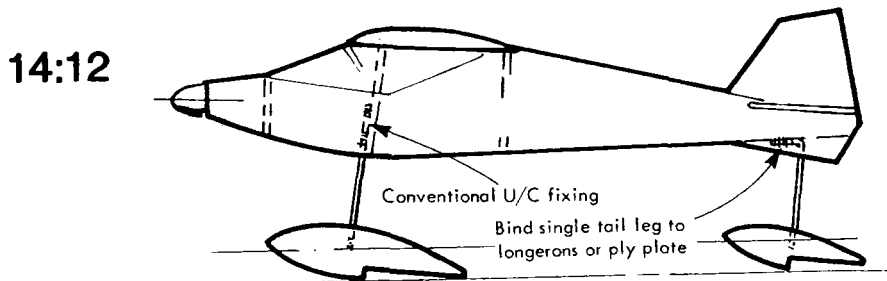

pliers, as in 14:11. If the float is held in the hand and twisted about, reference will be difficult and damage could result. Aim to fix the landing gear so that the model sits at a slight positive angle, as 14:12, otherwise it may not rotate for takeoff.

Flying boat hull bottoms can be made from a foam block in a conventional fuselage structure, as in 14:13, or sheeted and skinned over in thin ply, or even made from ply alone (14:14 and 14:15 respectively). Sharp protruding edges to the bottom will throw the water clear of the sides – these are called 'spray strips'. Glass fibre cloth cut into narrow strips will reinforce the joints (epoxy and fill smooth).

With just a hull, to sit upon the water, a flying boat needs stabilising 'sponsons' when at rest. These may be used in place of the more vulnerable tip floats. They come in for rough treatment when setting down on grass, however, so a stout spar (spruce) should be passed right through the fuselage as in 14:16. Alternatively, they may be

detachable, retained by a long nylon bolt entering a waterproofing grommet to reach an internal blind nut (14:17). The sponsons themselves would be best carved from solid balsa, faced with  $\frac{1}{32}$ in. ply below.

Tip floats will get knocked off, so have them captive by allowing them to pivot as in 14:18. A breakable peg or small brass bolt keeps them straight until that gust tips her on the grass, or flotsam gets in the way. Note the ply plate to prevent the float knocking a hole in the wing. This will not be needed if the wing is so high and of small tip chord that the float passes the trailing edge.

### 'Wellies'

Wheel spats to you – These may be vac. formed from ABS sheet, moulded in glass fibre or carved from balsa. Dealing with the last first, 14:19 shows section and side view. A ply lamination or inset plate spreads the load from a metal fixing plate.

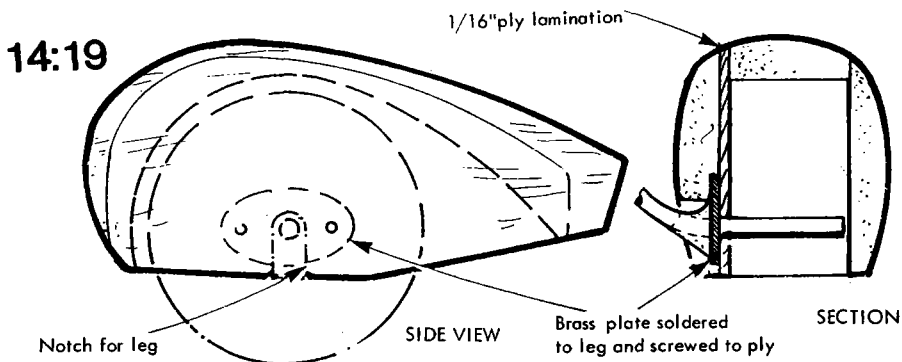
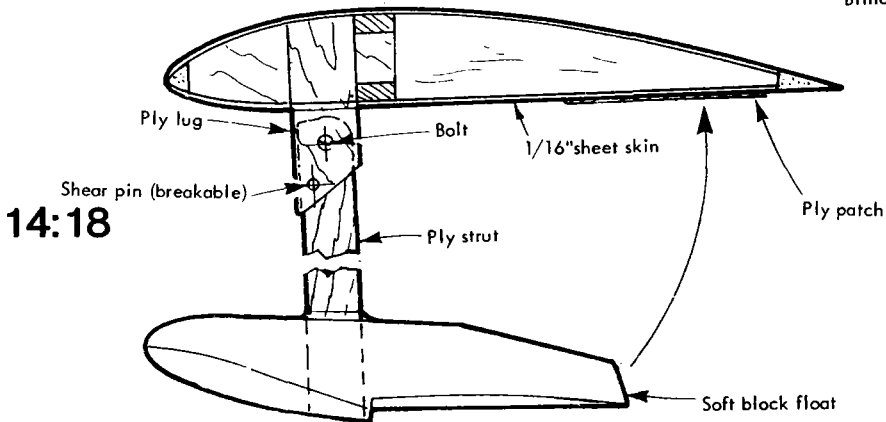
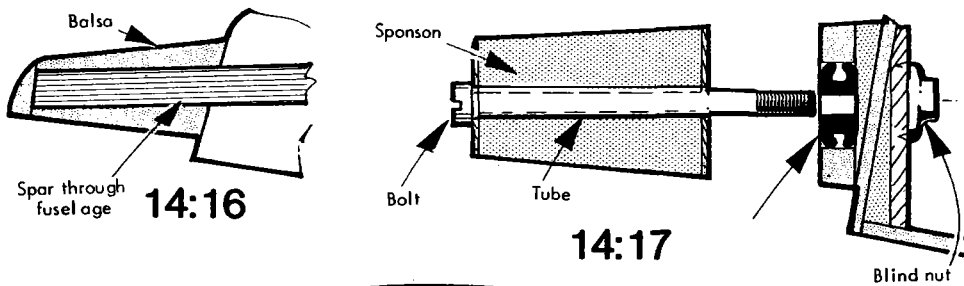

14:20

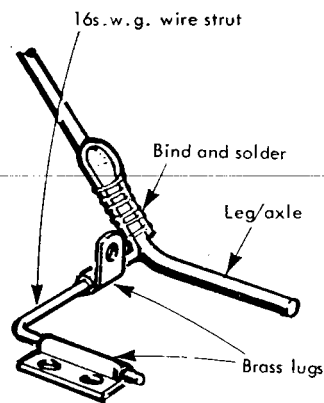
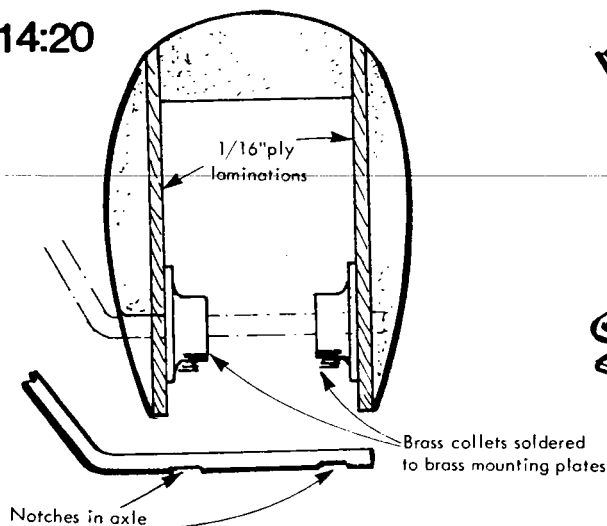

14:21

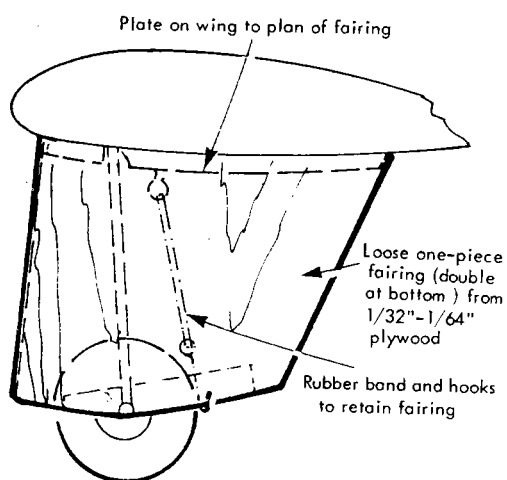

14:22

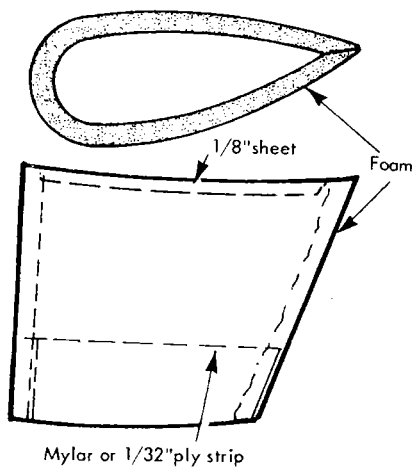

14:23

The outer end of the axle can also support the spat as in 14:20. Thread the wheel on inside the spat, then tighten the collets. The spat can knock up or down, but re-tightening both collets remedies this. The flats filed on the axle should go deep (about  $\frac{1}{4}$  of the dia. at least) for firm seating of the setscrews, but too deep a flat inboard will weaken the axle. Spats can also be supported by a wire strut, in addition to the soldered plate. This is seen in 14:21 and places less strain on the soldering. Be sure to cut a large clearance aft of the wheel because grass gets trapped there and jams the wheel. The long gap allows it to brush out again.

Leg 'trousers' – *Chilton DW1* for example – can be added to completely change the appearance of an undercarriage that is wing mounted. The fairing has to be loose so that it knocks off in rough ground or if the leg goes far back.

Sketch 14:22 shows how to make and fit the fairing. Alternatively, if the spectator does not come too close, a sponge plastic version can be installed and fixed – it will bend as the leg moves. Cheap and expendable this one, in 14:23.



# CHAPTER 15

## Electric flight and CO<sub>2</sub>

**Motor mounting  
Installation  
Special details  
Geared drives  
Folding props  
Flexi-drives  
Free flight  
Round the pole  
CO<sub>2</sub>**

This chapter deals with installation details for the power plants, including a CO<sub>2</sub> motor. The type of airframe construction used by most followers of the art of electric flying is lightweight, but having regard for the weight of the battery locally strengthened. The three principal classes are: Aerobatic, which have 3 or 4 channel ultra-light radio systems and a direct drive model racing car motor which can run for 4 or 5 minutes per charge – see 15:1.

Duration machines are effectively powered gliders, often with geared motors and folding propellers. Light and high aspect ratio wings keep them aloft for around 15 minutes when there is lift about. (15:2).

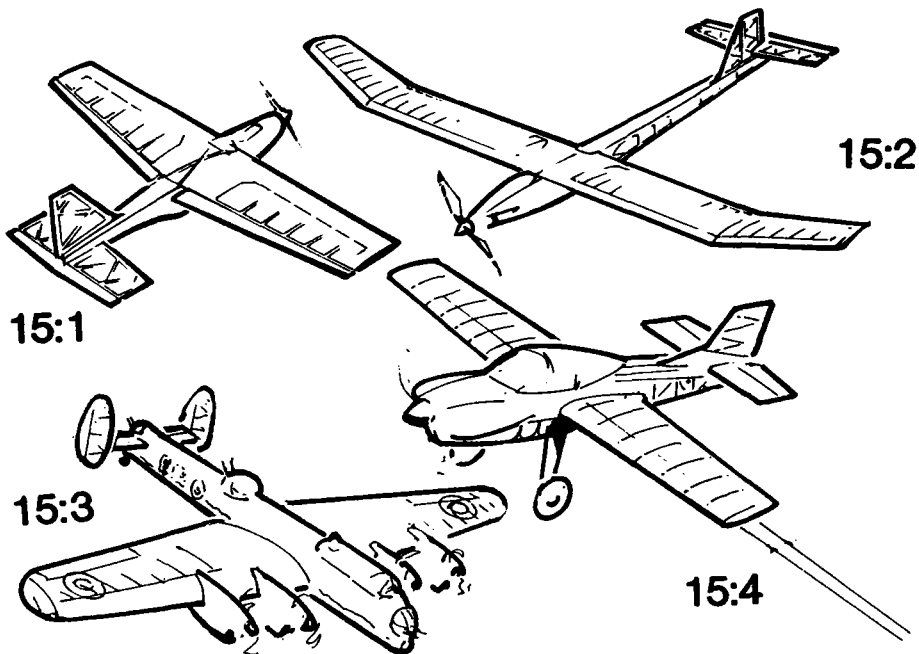

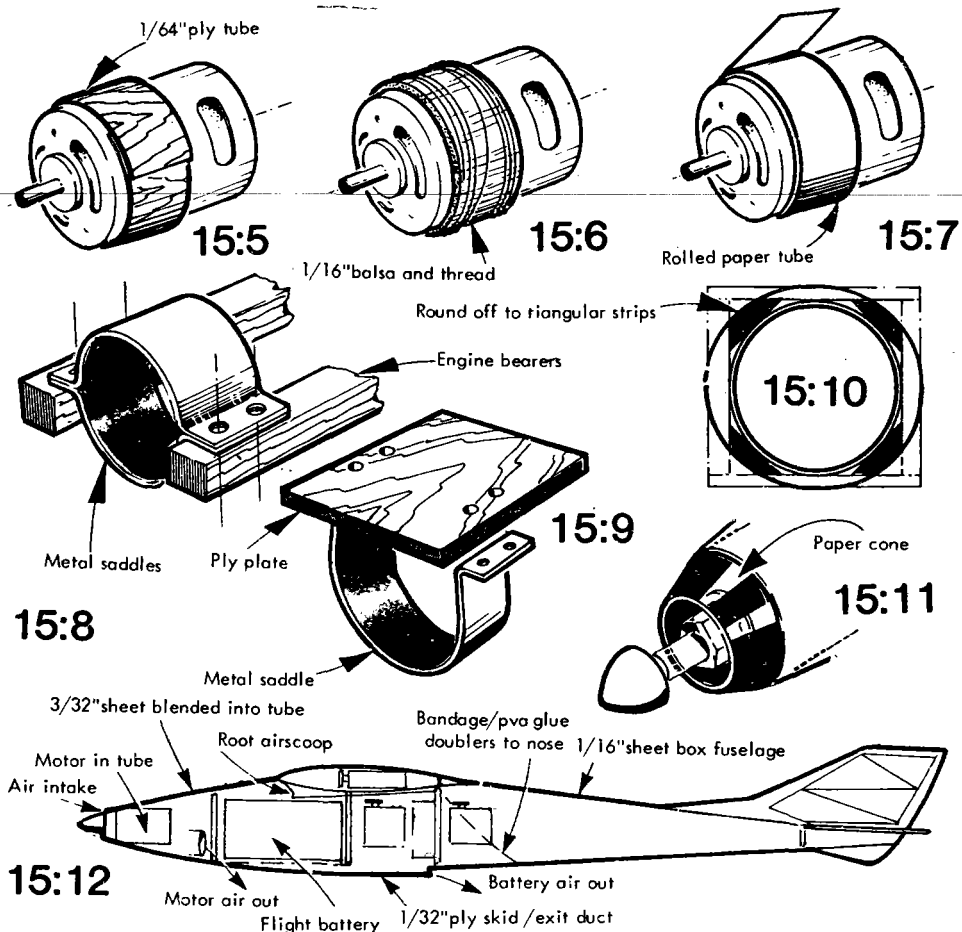

Electric power facilitates the building of reliable, if short, duration (4-5 min) scale subjects including multi-engined types, as in 15:3. Even control-line is possible. Some light models intended for free-flight and engines of around 1/2cc. to 1cc. can carry a model car motor and flight battery, when strengthened locally, see 15:4.

In fact, there are a number of vintage free flight power models which can carry either direct or gear-driven electric systems and light 2 or 3 function radio. These are mostly open frame, tissue covered machines in the sports category. Motor installation is simple. The direct drive versions entail making a tube to fit over the motor, leaving the air vents clear. Wind a strip of ply (15:5), sheet balsa, as in 15:6, or brown gumstrip paper, as in 15:7, to fit actually on the motor. This should be a tight fit. The gumstrip will stick to the motor unless the first couple of turns are laid gum side out, then the rest gum side in.

15:8 shows how to mount a motor in engine bearers (if they are the right spacing) or on a ply plate if they are not – see 15:9. Those motors in tubes can be built into the fuselage nose as in 15:10; leave the motor in the tube while doing this. To streamline the nose more, add a conical ring of gumstrip (formed on an old spinner) as in 15:11. It is recommended that a matching spinner is not used, as air has to pass easily into the motor for cooling.

15:12 shows a typical installation of motor, flight battery and radio

in a fuselage. Note the cooling for motor and battery (which also gets hot under load).

In order to get the best performance out of the model, whether it is intended for aerobatics or duration, drag-producing things like protruding control linkages, wing dowels and bands, undercarriages and over-bulkiness of the fuselage should be eliminated. Sketch group 15:13 suggests methods of utilising the wing seat fillets as airscoops, and the resilient ply bottom skid as an air exit. Control horns are inside the tailplane root and fuselage and the prop driver is spaced forward with a collar to give a more tapered nose. Do not omit the collar: it reduces the chance of bending the motor shaft on landing.

Gear or belt reduction drives permit the use of larger more efficient slow-revving airscrews. The British 'Olympus' has a small toothed belt and ballraced shaft – see 15:14 for side view and ply mount. 15:55 shows an imported gear drive unit intended for powering gliders. The long prop shaft has a coupling intended to absorb the starting jolt and save the gears if the prop contacts the ground power-on.

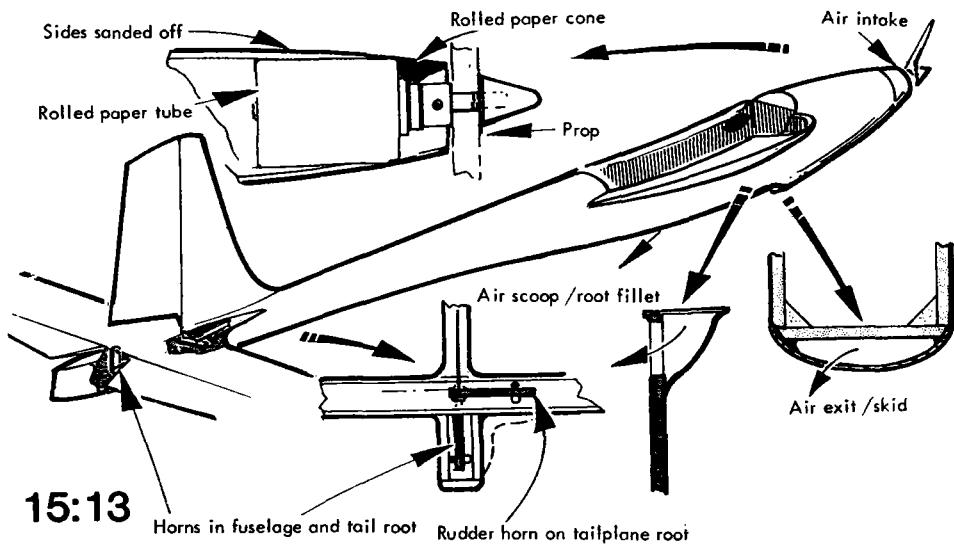

15:13

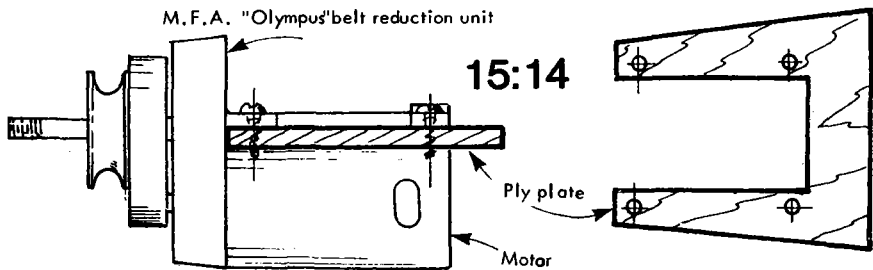

15:14

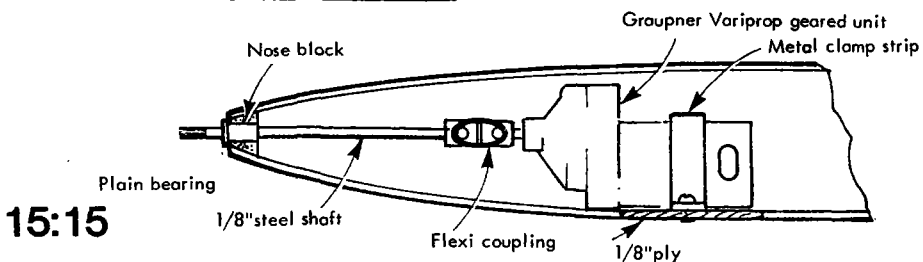

15:15

The systems discussed so far have used 1/12th. scale model car motors, but smaller motors with gearboxes are sold for use in Acoms kits. These units have plastic bearers to which they are held with rubber bands for crash resistance.

Many modellers have used them in freelance scratch built models with success. 15:16 shows a low drag nose detailed. The battery is a six cell flat type, intended on the kit models to be carried externally, but here fitted in through the side.

As sold, the prop, efficient as it is under power, does produce drag when stationary, so those who want to make it fold like the larger geared types may like to try the method shown in 15:17. Remember to check that blades will fold right back along the fuselage sides – the hub piece must be wide enough for this. The blade pitch will increase with the diameter, so trim from the centre.

Electric motors can be placed where convenient and the shaft taken to nose or tail end. Sketch 15:18 shows a pusher layout employed by the author, one of several variations. The brass tube is fixed but free to flex slightly, for alignment at each end. It is important to use thin piano wire for the shaft in this example. Other shafts of about 6in. length have been 1/8in. dia., supported only by a short tube in the noseblock.

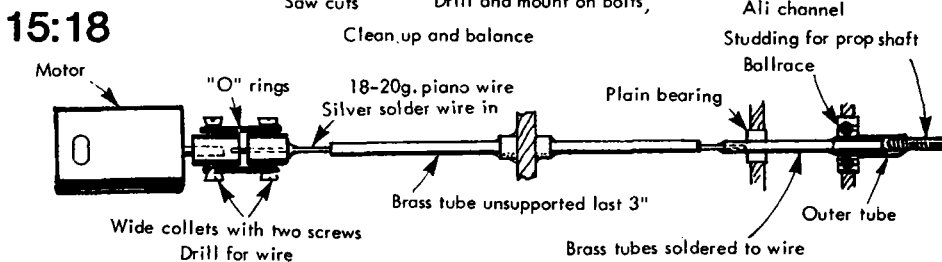
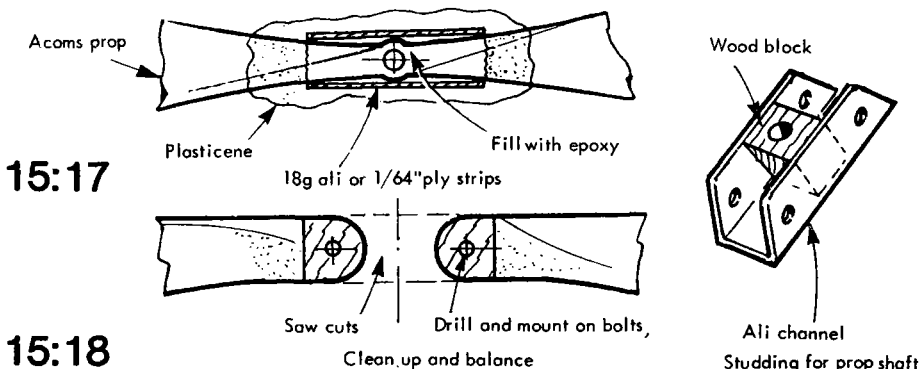
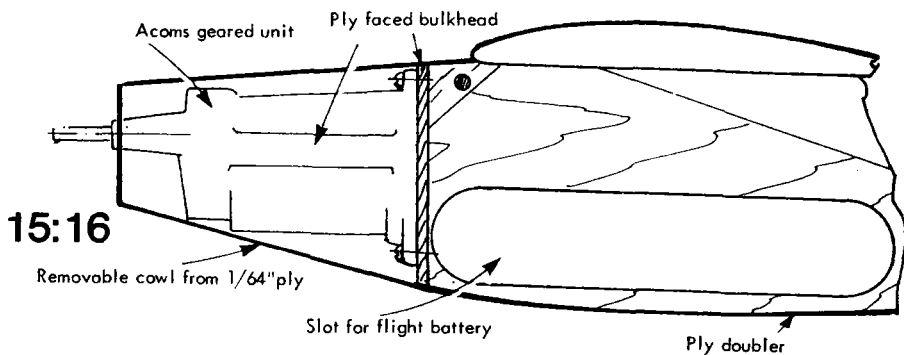

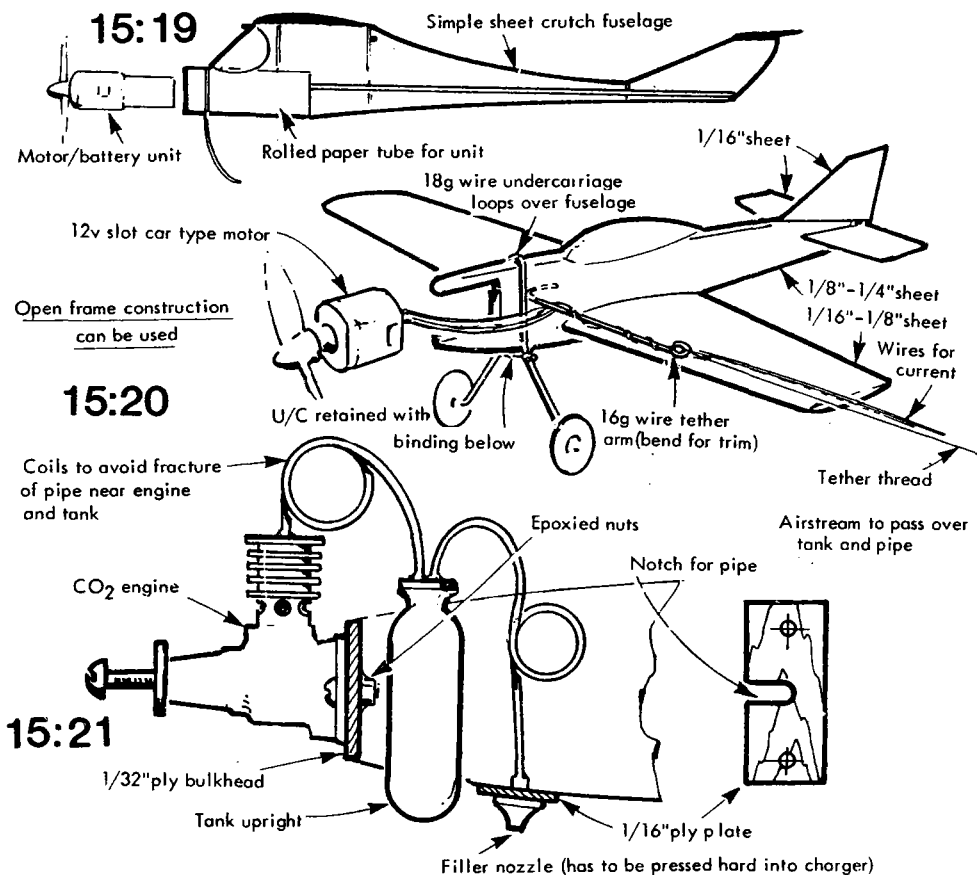

### Free flight and others

Even smaller motors are sold, some complete with battery and prop, for use in free-flight models. These run for a very short time and to get anything like long duration the model should be light and simple like a small rubber powered model.

Round-The-Pole flying is an indoor activity, requiring a circle of not less than 10 feet dia. The motors are sold specifically for this type of flying and plastic props are available for both direct and geared types. A basis for starting could be similar to a very small control line model, but there is no elevator control. The model receives 6-12v. D.C. via enamelled copper wires and a collector brush system on the top of a short firmly based pole. A model slot car speed controller is used and this causes the model to climb on full power and descend when the power is suddenly reduced. Sketch 15:20 may indicate proportions of a 10in. span machine. CO<sub>2</sub> Engines are mentioned here because they come into the free flight miniature class along with the smallest electric models. Sketch 15:21 shows a typical engine mount and provides for the gas tank, which should be upright, so that only gas, not liquid, enters the engine. The filler nozzle can be supported by a finger behind it, if a hole is left in the fuselage nearby, otherwise provide sheet area to grip when refuelling the model. Duration models of up to 28in. span can be flown and CO<sub>2</sub> is suitable for sports and scale models including 'Peanut Scale', but at lower duration.

# CHAPTER 16

## 'Foam' construction

**Cutting cores**  
**Reinforcement**  
**Veneering**  
**Joining**

When veneered expanded polystyrene construction was introduced for wings, some modellers adopted it as a short cut to the finished model, kit manufacturers welcomed it and whole models were produced by injecting the material into moulds for skinless almost-ready-to-fly kits. Was this the end of balsa construction? Well, foam/veneer weighs more than balsa construction, is less adaptable to compound curves and is melted by fuel and some paints. This chapter shows how to adapt it to serve the model, rather than the reverse.

Sketch 16:1 shows a couple of typical applications teamed with traditional construction.

For our purpose, a suitable sheet of expanded polystyrene foam can

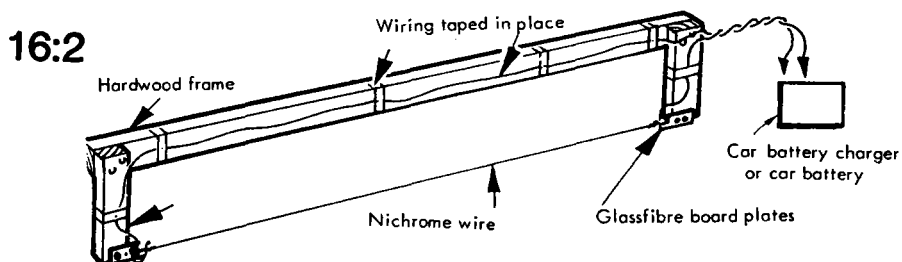
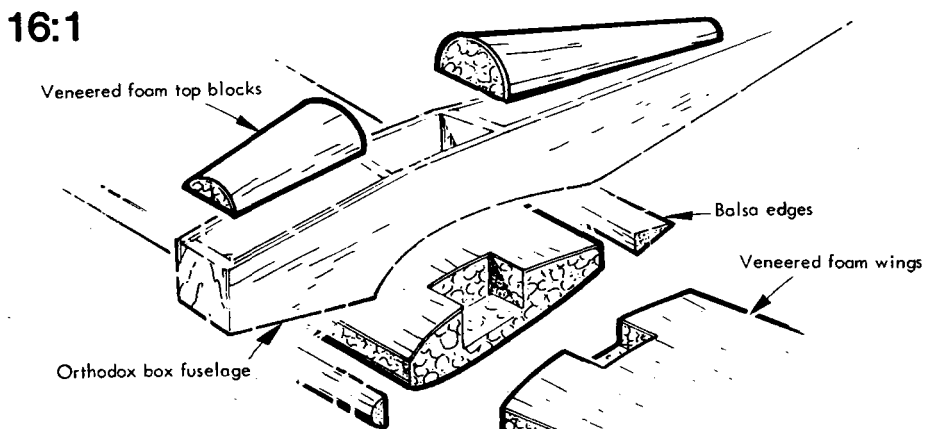

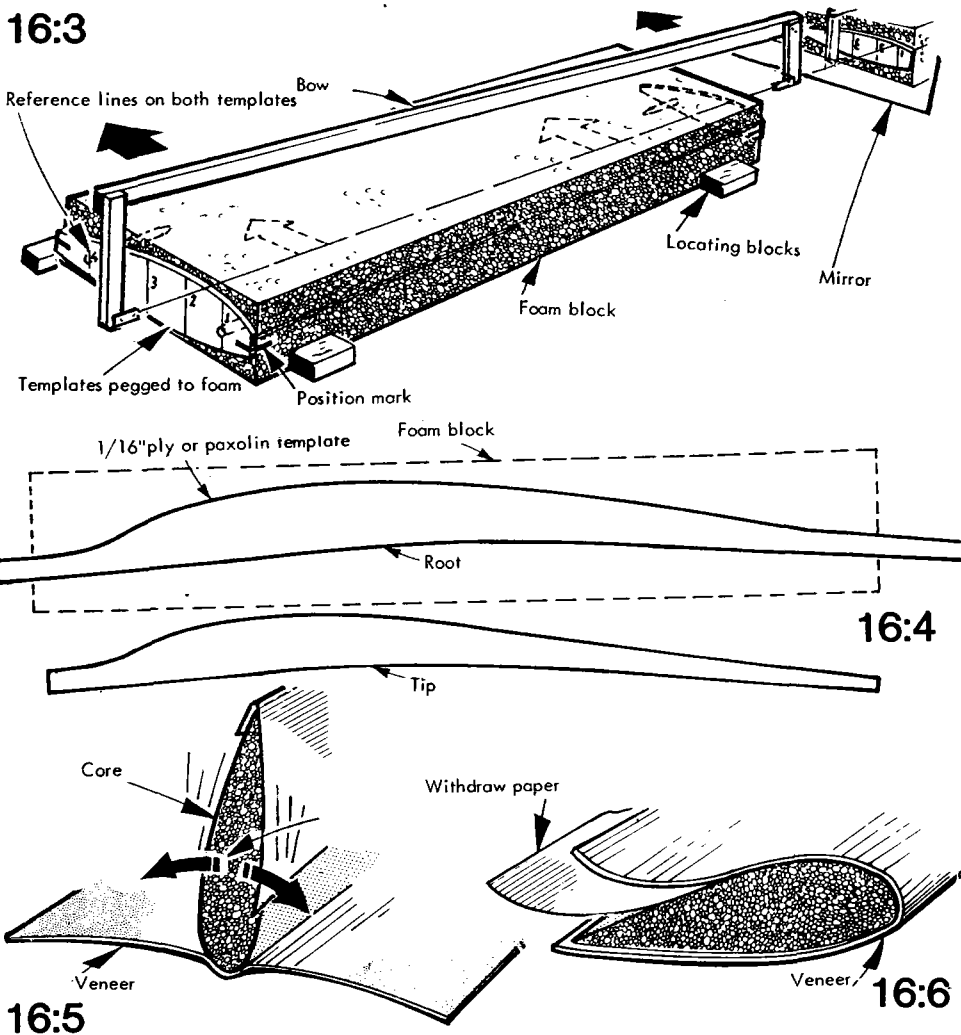

be cut to shape, with a hot wire bow seen in 16:2. There are variations on this theme, even commercial examples, but the basic requirement is that the wire is longer than the wing panel you wish to cut and deeper than the deepest aerofoil section, plus a couple of inches. The wire must be really tight.

Start with a pair of ply or Formica templates, identical for parallel chord wings, or one for the root and a smaller one for the tip when the panel has to be tapered. Divide these up into an equal number of stations and stand a mirror near one end, so that after fixing the templates in place, the bow can be slid over their smoothed edges station-by-station, with accuracy and single-handed. Sketch 16:3 explains. It will be observed that should one end of the bow reach the end of its travel before the other is say, half-way there, the aerofoil will have a hollow or over-thinned zone in it . . . The material is low in cost, so discard 'mistakes' or use them for smaller parts.

It may be preferred to make the templates with 'lead-ins' as in 16:4, which is helpful when the leading and trailing edges have to be wire-trimmed for fitting balsa leading and trailing strips.

If the veneer has to go round the leading edge; study 16:5. Copydex

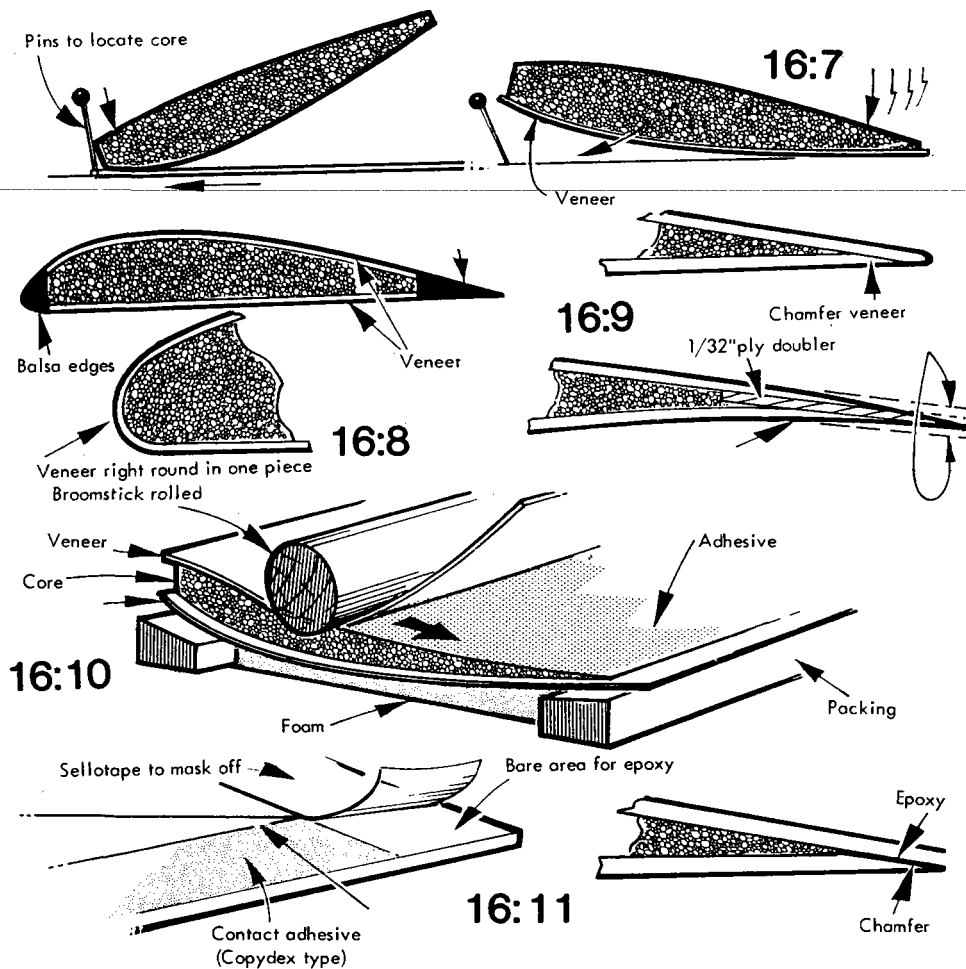

or similar adhesive is used and the veneer may be  $\frac{1}{16}$ in. balsa, or thinner obechi. The paper is to prevent premature adhesion. 16:6 completes the job.

Two separate veneers (for top and bottom) can be applied by using locating pins or stops on a perfectly flat bench. In all cases, make sure the core and veneer are evenly coated with the adhesive. Mix a little food colouring with it so that it shows on the white foam surface. 16:7 shows the stages of applying the veneer. Treat each side separately to avoid the fingers sticking to the core.

16:8 compares leading edge details and shows that the veneer is butted to the strips – trim the veneer edges flush with the core first.

The trailing edge can be formed by the veneer alone or if thin can have a  $\frac{1}{32}$ in. ply insert as in 16:9. Undercambered and thin wings are more flexible during the veneering stage, but packing helps to keep the core warp-free and even rolling of the veneer avoids air bubbles (16:10). Where it is required to join the veneer at the trailing edge, a stronger adhesive is recommended. Epoxy is compatible with foam but the Copydex acts as a resist. However, if the veneer is measured dry a strip of masking tape or Sellotape can be applied prior to the contact Copydex. Peel off the tape and apply epoxy after starting to bond the veneer in place – see sketch 16:11.



Thin wings may need spars in addition to the load bearing veneer. In the interests of accuracy, a second core template can be used after cutting to aerofoil shape. The one shown in 16:12 guides the cutting wire at the spar position in addition to leading and trailing edges. In fact, such a wing, sectioned in 16:13, can be covered with lightweight glass cloth and brushed with epoxy, which will not melt the foam. Blue foam is sold for modelling and is denser than expanded polystyrene. The spar details come from a contest glider wing and include double wire joiners and carbon fibre spar reinforcement (more about the latter in the next chapter). Flat bottomed wings are easy to assemble each side of a composite spar – compare 16:15 with 16:13, which has to be packed up or assembled on a jig. Flat spruce spars can be let in flush as in 16:16; in this case there is no continuous web but short pieces of balsa dowel are epoxied into holes in the core (cut the holes with a smaller dia. heated rod or tube).

Tailplanes can be treated in a similar way. 16:17 is a typical section with or without carbon or glassfibre on the spar. Smaller models can be

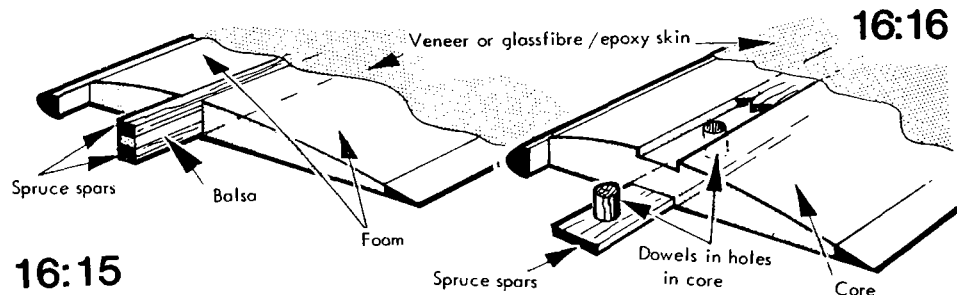
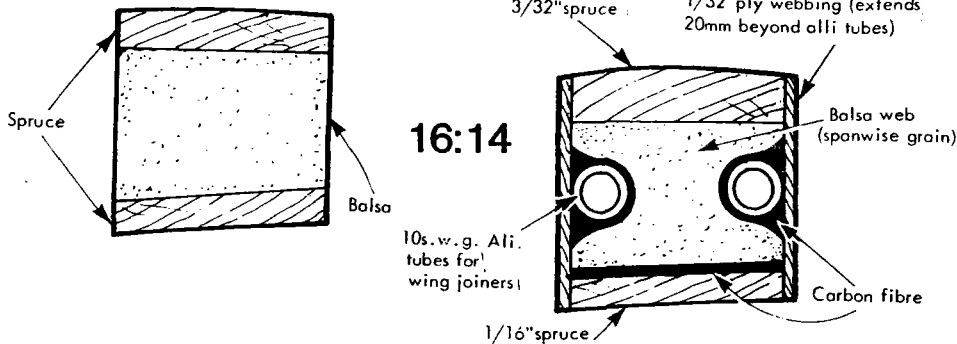
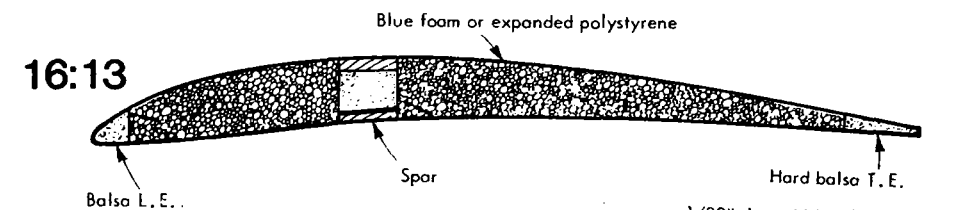
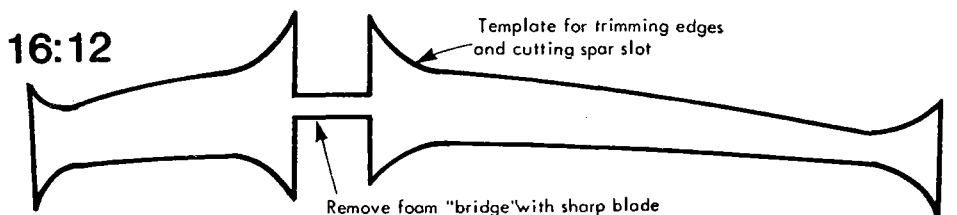

film covered, but go easy with the heat shrinking (see Chapter 18, on covering). The strands of glass fibre, or carbon fibre epoxied-in, need masking tape or Sellotape over them, while curing only, as seen in 16:18, to leave a smoother surface.

Brown paper, of the water-resistant variety, makes a reasonable structural covering, but restrict it to the thicker type of aerofoil when used on wings and tails.

Spars augment its strength in thinner sections, as in 16:19. The weight of a veneered core can be reduced by fretting it out. Use a very fine tooth blade slowly and lightly (16:20). Scale modellers can apply dummy structure over a plain veneered wing, then use tissue or fabric to cover it . . . Looks good, see 16:21.

Partial veneering with  $\frac{1}{16}$ in. sheet as in 16:22 should only be film covered.

### Joining foam wings

A popular method of joining veneered foam core wings is to butt-join them with epoxy adhesive, then apply glassfibre tape bandages as in 16:23. Although some prefer to use polyester resin for this final stage,

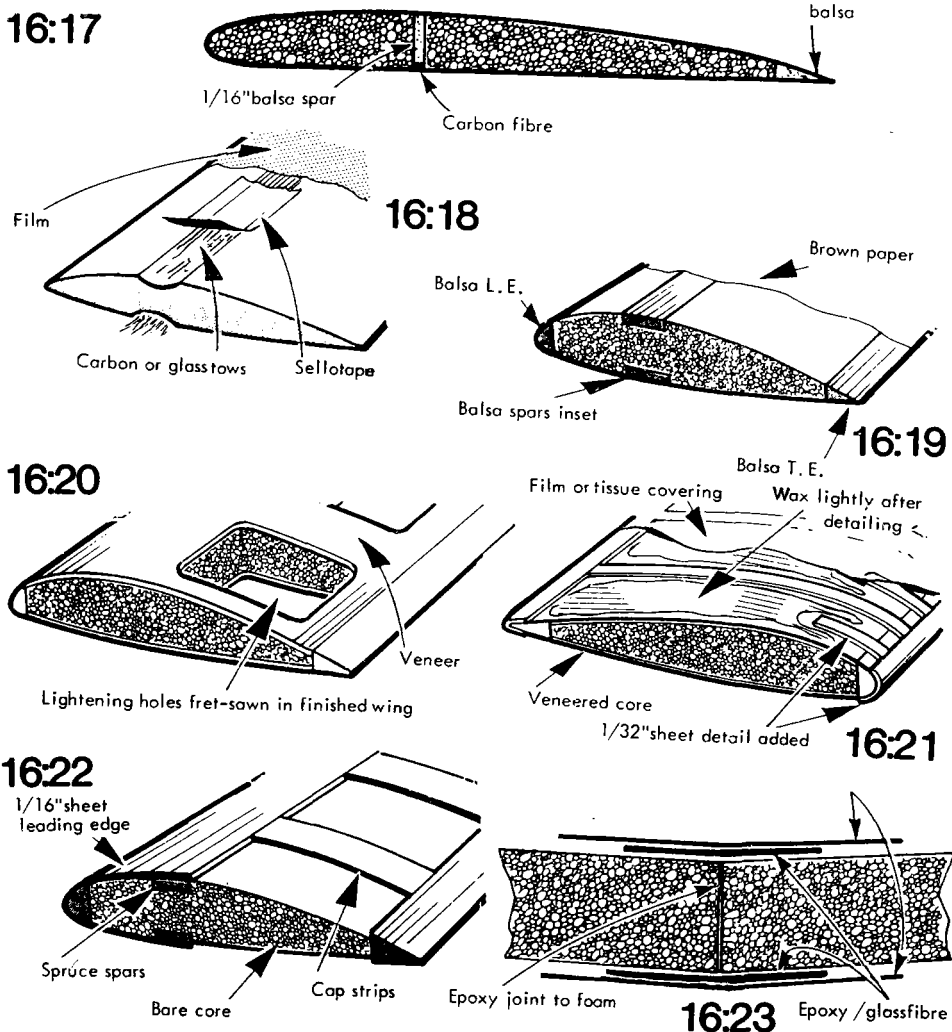

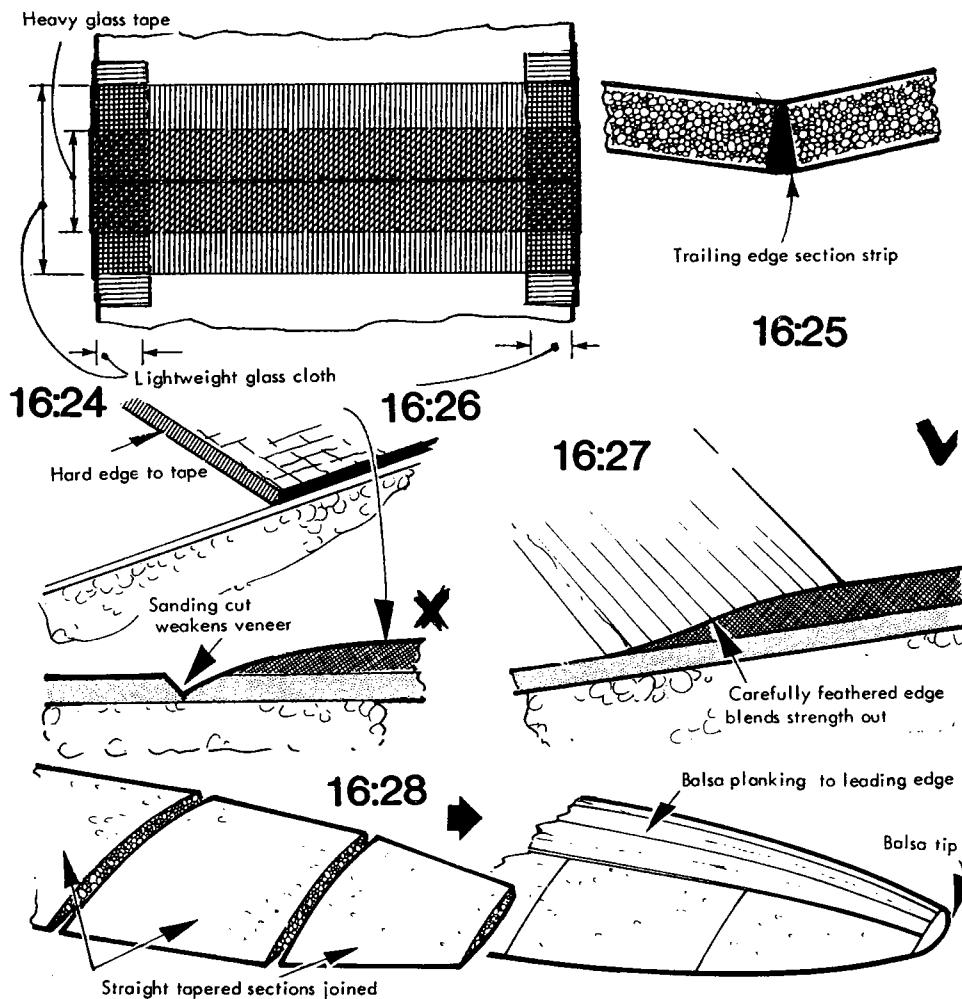

polyester melts the foam, so if there is a small gap in the veneer, the core will be weakened.

A very secure joint results when strips of light glasscloth or tape are applied to the leading and trailing edges, in addition to the two jointing layers; see the plan view in 16:24. Dihedralled wingtips, or for that matter, the centre join, can be formed by sanding the core faces vertical and inserting a strip of pre-shaped balsa trailing edge as in 16:25, before applying a narrow strip of bandage. Some modellers use medical bandage or glassfibre bandage and PVA glue as an adhesive for the joint. This is lighter and more resilient – not quite as strong, though.

The reason for using two layers of glasscloth is to feather the joint out gradually onto the wing veneer. A sudden change in strength causes fractures, so does an accidental thinning of the veneer whilst sanding the roughness off the joint, as has happened in 16:26. Masking tape on the veneer prior to sanding and more care should result in a section like that in 16:27.

Elliptical planforms are just possible (16:28) but hardly worth the use of foam.

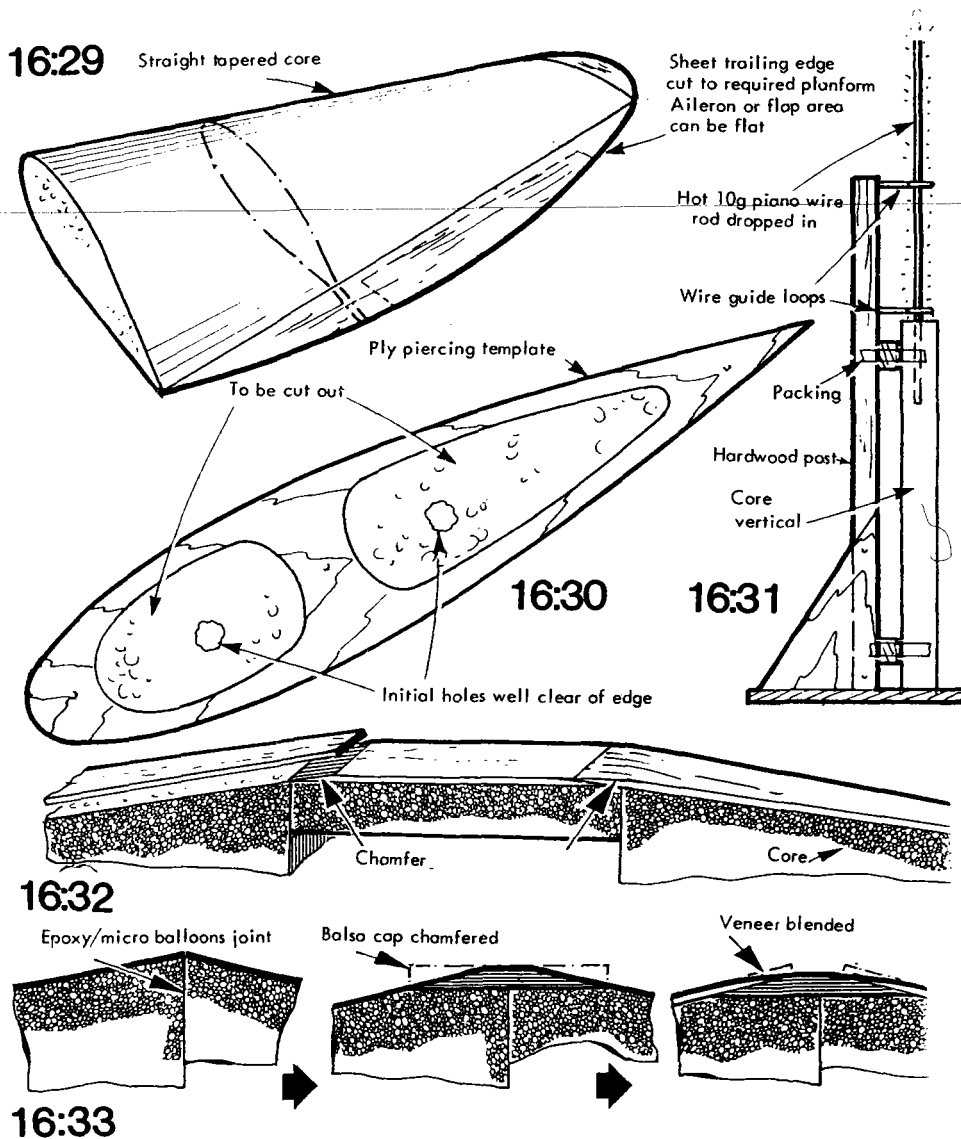

However, if one is prepared to have a shaped flat panel at the trailing edge and a straight leading edge, 'Spitfire'-like silhouettes can be made as in 16:29. The sheet area can be used as flaps and/or ailerons.

Suppose the core is a large and thick. It can be lightened by making it in top and bottom halves and wire-cutting sections from the centre, leaving a wide strong, web. When joined, the wing is veneered in the usual way. Another method can be used when the core is in one piece; it is seen in 16:30. This entails threading the cutting wire through the core from root to tip to cut out the centres. A heated length of thick piano wire will make the starting holes for the wire, but to ensure that it goes straight down and not out through the side, the jig in 16:31 may be used.

Do not be tempted to just melt away foam to lighten it . . . the weight remains the same. Get the scales and try it! It has to be cut away.

Fuselages can be built with rectangular and tapered blocks, per 16:32. Rounding is more tricky, but joints can be blended on curved cross sections, as in 16:33.

# CHAPTER 17

## More materials

Cardboard  
Tubes  
Twinwall  
Epoxy/glass  
Kevlar  
Metal

This is where the old joke about forgetting the kit and flying the box comes to life . . . Good quality corrugated cardboard has been successfully used in building simple radio control models. There are several types of board, as will be seen in sketch 17:1. The building technique starts with 17:2 which shows a flat bottomed wing; the cardboard takes the place of sheet balsa and is rather heavier, but the rib spacing may be wider. The double skins have to be bent in a series of flats, so the aerofoil section is rudimentary. Flat surfaces, such as tails, however, are easy, as in 17:3. Note the edge treatment and use of double strips of balsa at the hinge line.

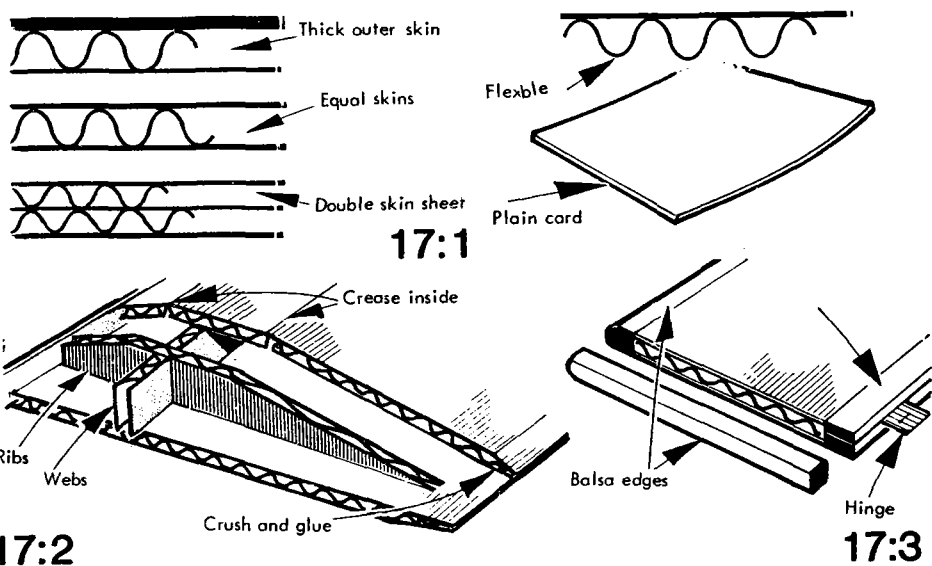

To make a bend, cut a narrow slit in one skin, preferably the inner one, as in 17:4 and fold. This bend, along the corrugations, is used in the curving of the top skin of wings. A wider slice is taken out from the inner face for 90° folds such as are used in forming a box section for the fuselage. Brown gumstrip paper reinforces the PVA glued joint, as in 17:5. More acute bends, as for example, a wing trailing edge, can be made by actually crushing the inner corrugations and gluing skin-to-skin as in 17:6. To join at a corner, prepare the edges with straight cuts and butt to a strip of balsa of the same thickness. Add gumstrip inside and out, as in 17:7. To kink across the corrugations to make the transition from parallel to taper, in fuselage sides, slice through almost up to the other skin. Bend open and sand away the cut edge slightly with glasspaper folded double. Glue and tape over when dry, all as in sequence 17:9.

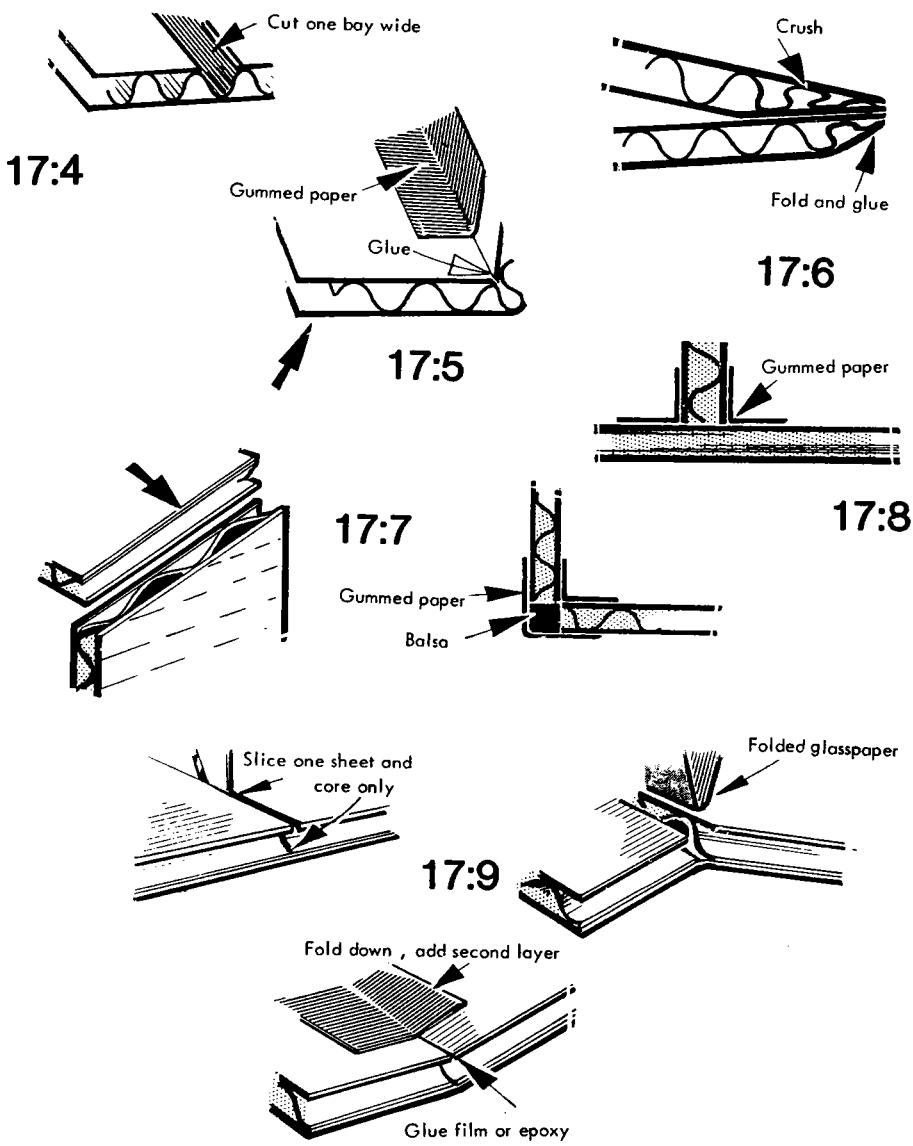

17:10

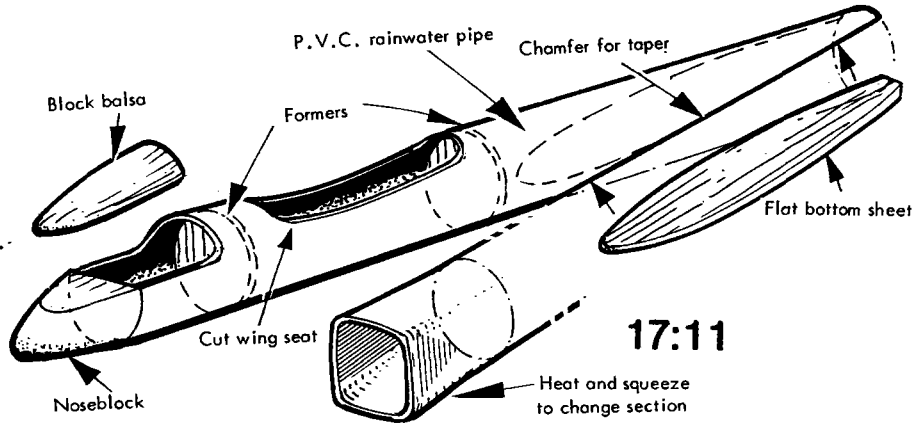
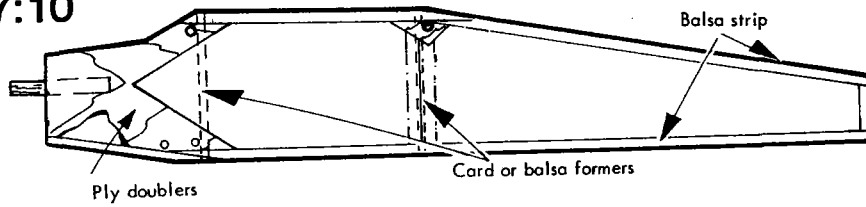

17:11

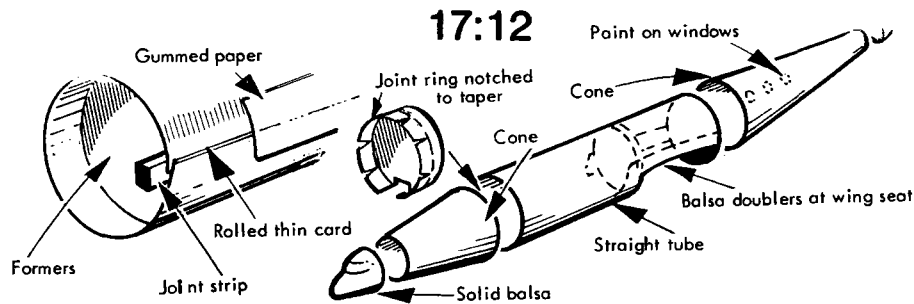

17:12

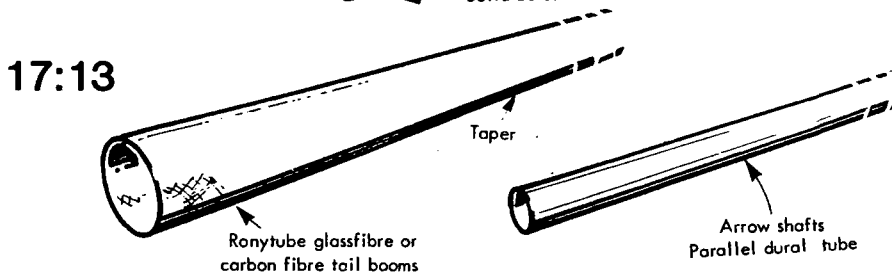

17:13

Formers can be made from the cardboard or balsa, but ply doublers will be needed to support engine bearers if it is a power model. Balsa strips are recommended at least around the wing seat, where the wear and stress are highest, see 17:10. PVC. rainwater pipe makes a serviceable fuselage, as in 17:11. The shape can be improved by tapering and filling the rear part. The material will soften under heat and can then be squeezed to form flats.

Plain white card can be rolled into tubes and cones for fuselages ('Prop Secret' was made like this, so was a Brabazon, Comet and Hermes). 17:12 explains.

Tail booms are catered for by specially manufactured 'Ronytubes', available in a wide range of sizes – they taper and are made from

glassfibre. Dural arrow shafts are useful too and can also be used as torque rods on large R/C models, see 17:13.

Some kits contain fuselage half shells in vacuum formed plastic. These need joining with the appropriate adhesive, per maker's instructions. Some need a solvent type adhesive which will mar the surface if spilt. A useful dodge is to tape the parts together at intervals, then introduce the adhesive between the tape strips. When set, remove the tape and fill in the spaces it covered. (17:14).

Expanded polystyrene ceiling tiles, or thicker sheets of this material, make simple flat-plate models, which, surprisingly, fly quite well under radio control, or in free-flight; see 17:15. A smaller version (and tailplanes too) can be made from 'Featherlite' Kapa board, see 17:16, Twinwall plastic, as sold for garden glazing, is another flat substitute. (17:17). Even wallpaper insulation works for small free-flight models and indoors - 17:18.

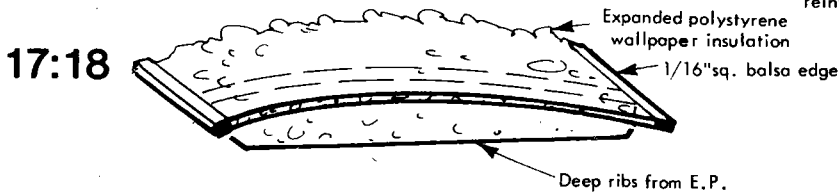
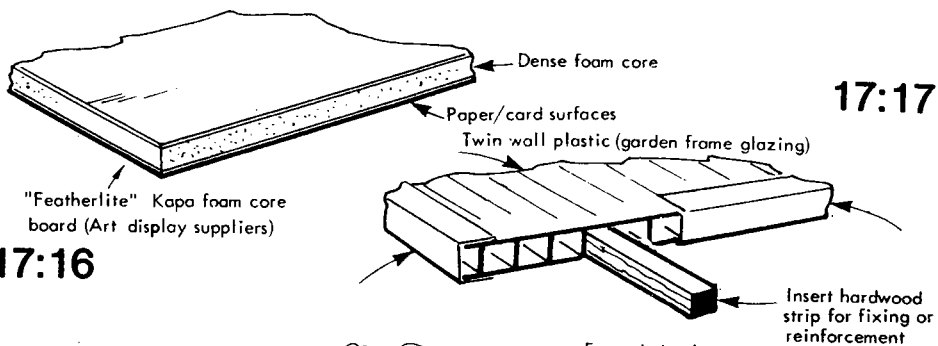
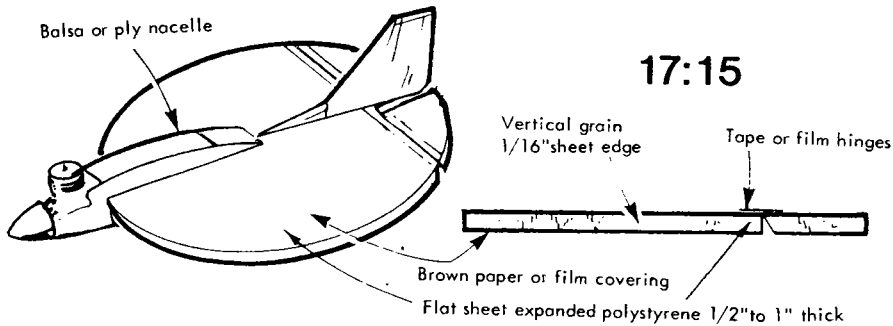
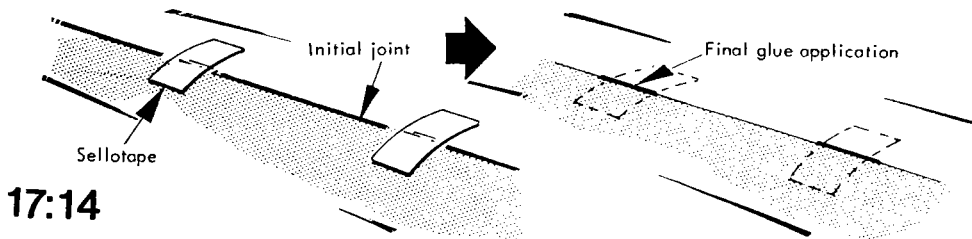



Fuselages and tail booms for small light models can be made from polymer film tracing material (drawing office supplies). The basic sections can be formed from a single thickness of film and end plugs from balsa or expanded polystyrene can be inserted to retain the shape, see 17:19. The film is available in a range of thicknesses.

Perhaps the ultimate in construction is in the forming of epoxy glass wing skins, which need little or no core or ribs to retain their shape. The top and bottom skins are load-bearing and each is formed separately in its own mould. Each skin is double skinned itself, having a thin expanded polystyrene core. The finished section is seen in 17:20 and the moulding set-up in 17:21.

Kevlar is another new material for laminating with epoxy and is lighter than glassfibre. One World Champs entrant formed a 'D' box leading edge over a hardwood 'plug' mould. It is suggested that a thin flexible metal outer mould is applied to provide pressure while moulding. The rest of the wing is balsa and terminates in a spar web to

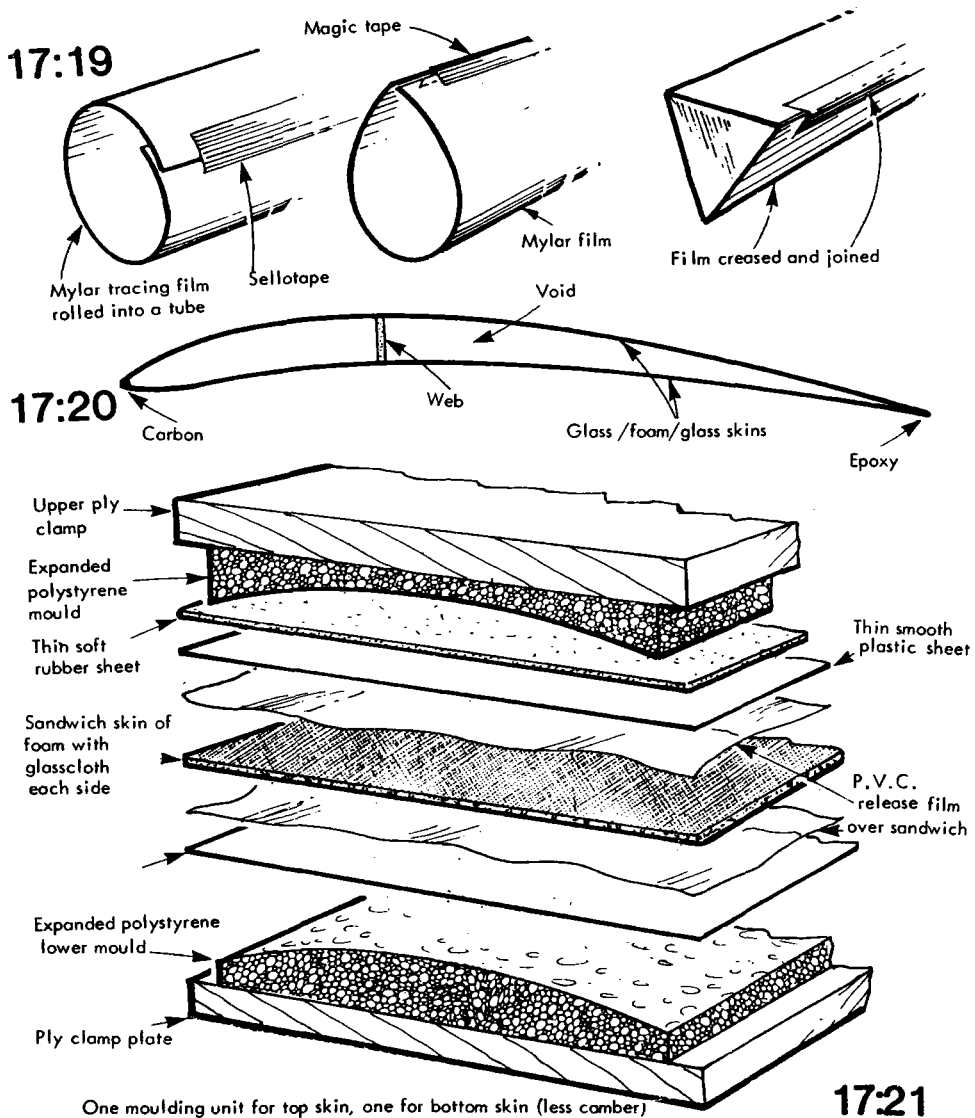

complete the box structure, which has no ribs. Sketch 17:22 shows the assembly and 17:23 the moulds.

Aluminium and dural sheet, litho plate and thin dural foil have all been used as wing skins, or rolled as tail booms. In some applications it is laminated onto thin balsa sheet using epoxy, then bent over a rib and web structure as seen in 17:24. The metal should form both skins, being bent at the leading edge by leaving a small gap in the balsa laminations. Strands (tows) of glass, or carbon fibre, reinforce this area. Such a wing is highly resistant to warps and has a super finish.

These last few techniques are presented here for inspiration, since one has to be a dedicated contest modeller to go to this amount of trouble to make a model. In any event, the design of the model needs proving thoroughly before a new version is made of it in these materials. These structures are not the sort of thing that you can chop about and modify easily.

17:22

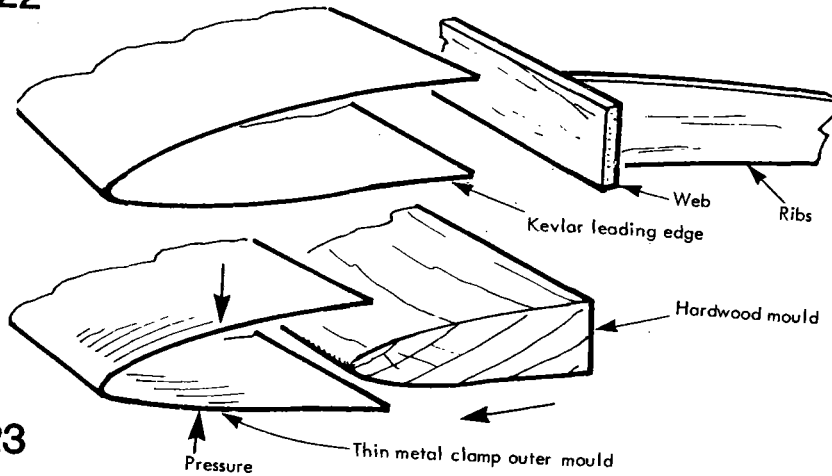

17:23

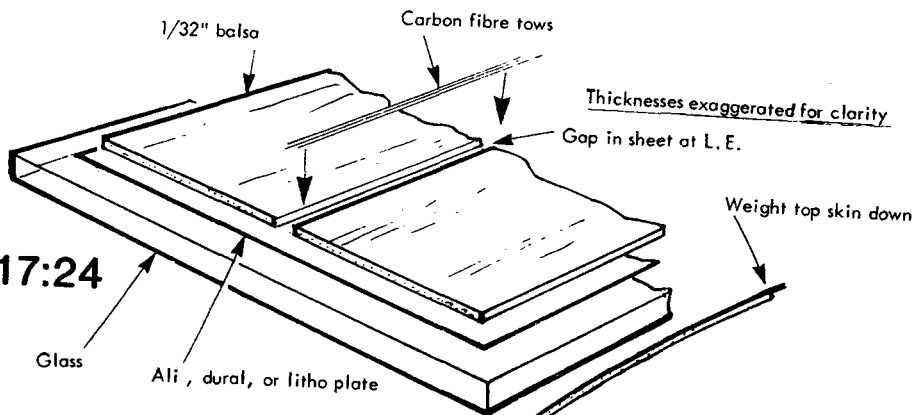

17:24

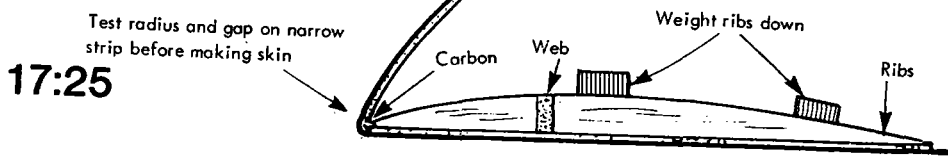

17:25

# CHAPTER 18

## Covering and finishing

**Tissue**  
**Nylon**  
**Film**  
**Surfacing**  
**Painting**  
**Decoration**

The covering of open frame structures adds rigidity and strength, as well as keeping the air from 'blowing through'. For many years, doped tissue paper has been favourite for light free-flight models, some lighter control-line models, small R/C and electric models. Jap tissue was much used when easily available, but is now virtually replaced by 'Modelspan', which has a rag content and is available in light and heavyweight grades. Time was when many colours could be bought, but now only white, and occasionally black, are easily obtainable. The trend towards radio control brought with it various alternative coverings, some of which are too heavy for the lightest of free-flight models. First, then, to apply tissue.

Each wing can be covered in a series of separate panels, cut about 1in. oversize as in sketch 18:1, which shows the order of fixing. Where there is dihedral, the top sheet ends will have to be trimmed to fit at a slight curve.

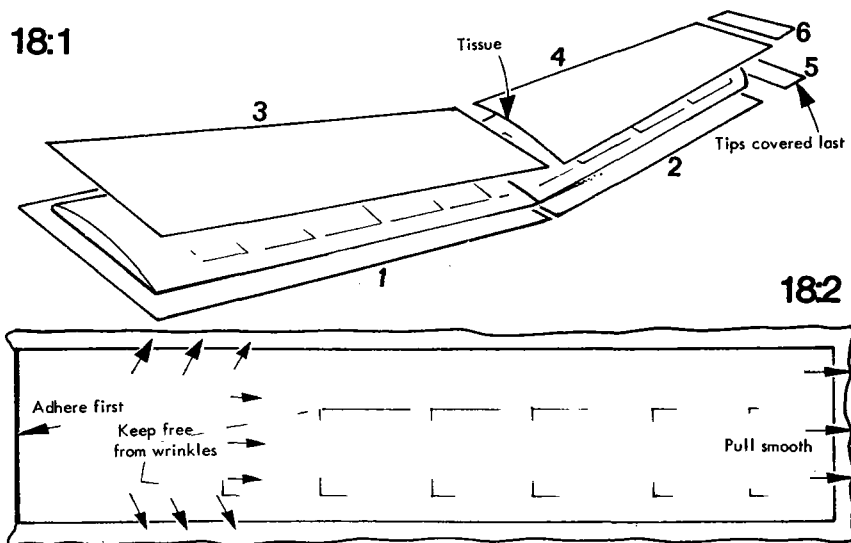

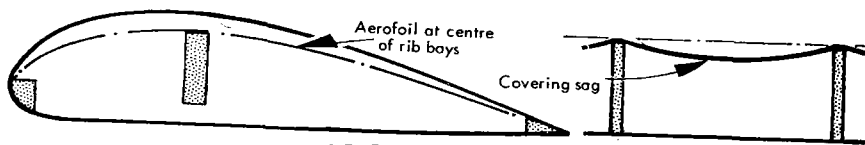

18:3

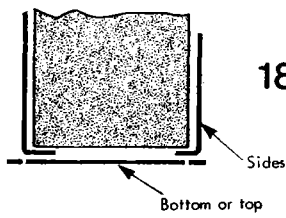

18:4

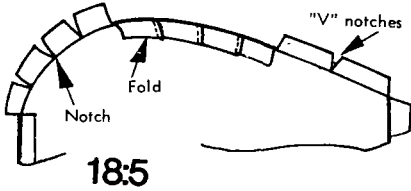
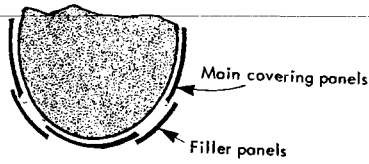

18:5

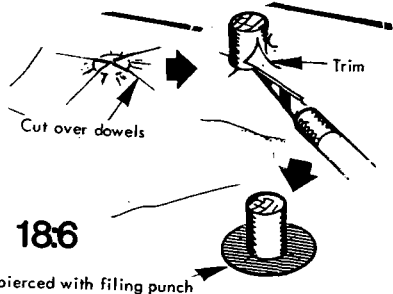

18:6

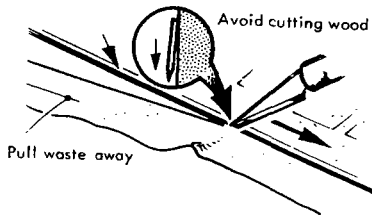

18:7

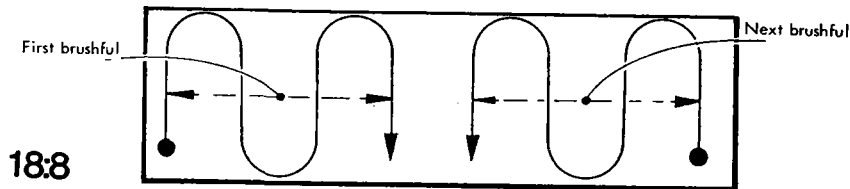
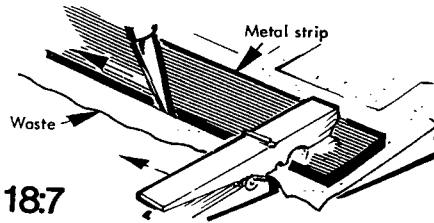

18:8

The adhesive used can be thinned down P.V.A. glue or thick wallpaper paste applied sparingly. Do one panel at a time and lay it down as in 18:2. Make sure the tissue sticks to the undercamber of each rib (if the aerofoil section is undercambered, that is).

Keep the spanwise tension, for tautness on the convex surfaces – top of any wing, and bottom as well on those of bi-convex aerofoil section. Sagging covering changes the aerofoil section to a thinner one (18:3).

While dealing with simple shapes, consider the flat sided fuselage. Cover the sides, using the same method, and fold over the waste, trimmed to 1/8in. overlap. Cover top and bottom and trim flush.

Where the sides change to a curved cross section, taper the ends to allow the tissue to curve and fill the spaces, all as in 18:4. Curved tips are notched to fold neatly, as in 18:5 and protruding dowels dealt with as 18:6. Edge trimming can be done using a straight edge or with greater care freehand (18:7). Tissue is then sprayed with water gently and allowed to tighten. Next, cellulose dope is used to shrink it further and airproof and strengthen it, see 18:8.

The bottom surface of each wing or tail panel should be doped first, using the brush stroke pattern just shown, so that the dope goes on evenly. It will now dry before the top surface, which is treated in the same way. Lightweight models need the dope thinned down with an equal, or less, quantity of cellulose thinners, otherwise the structure will suffer. Two or three coats are usually enough. Pin or strap the component onto a flat board when touch dry, until the shrinking is complete (several hours or overnight) 18:9 shows it banded down and 18:10 pinned. The pins do not go through the wing.

If the wing or tail shows wrinkles when forced down onto a flat surface, you can be sure that it has a warp or will soon succumb to one. 18:11 and 18:12 show how to identify which way it will pull. To correct and give the surface a nice polish, rub with a rag dipped in thinners as in 18:13. Holding the offending area in steam whilst twisting it to over-correct will also help.

### Film covering

Heat-shrink plastic film is available in bright colours and can be lighter than heavily doped heavyweight tissue or silk or nylon (which also have to be doped). Marking out is done per the last example, but

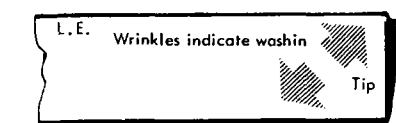
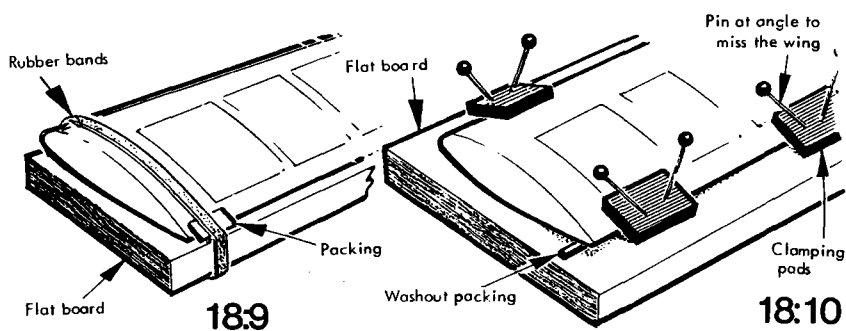

18:11

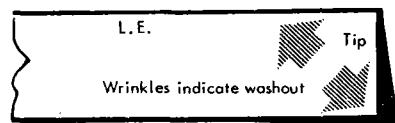

18:12

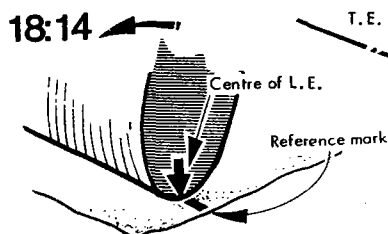
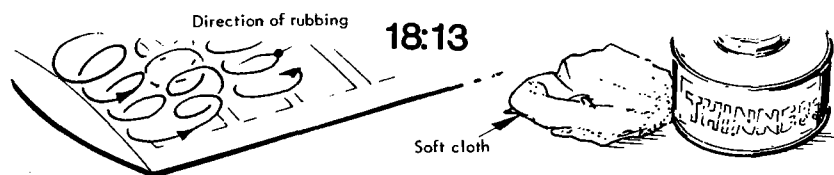

18:14

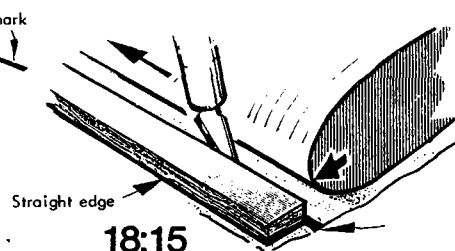

18:15

where colours are to meet at the edge put a reference mark as in 18:14 and trim as in 18:15.

A specially made heat-shrinking iron is sold for the purpose of fixing and shrinking the film, but a light domestic travelling iron will do. The film comes with full instructions, as does heat-shrink fabric (for heavier duty). The following tips may help in the sequence of applying heat-shrink materials.

Tacking is a light application of the iron to fix the material temporarily. A spot tack just prevents it skidding about. 18:16 shows how to start a wing or tail. Curved areas need pulling, so have plenty of surplus film to grip as in 18:17. This bit takes a little practice, but when done neatly, is surprisingly effective. Fuselage panels are dealt with in sketch 18:18, whether on sheet or open frame. Where a film panel has to be taken over the leading edge for colour scheme detailing, do not bond it down fully or shrink it in that area. The scrap of balsa on the blade in 18:19 gives the overlap, finishing as in 18:20. The underside lap on trailing edges can be cut along a hardwood strip as in 18:21 and finished as in 18:22.

When a slot or small hatch is encountered, the chances are that the iron will burn the film at the edges, whilst trying to fix the opposite side.

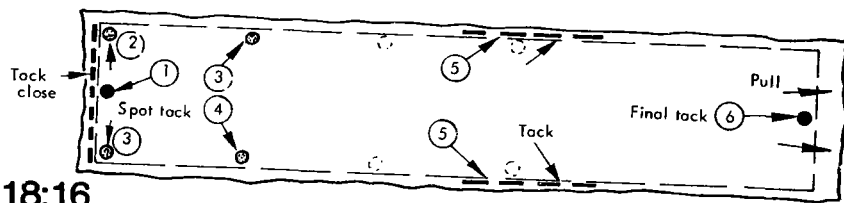

18:16

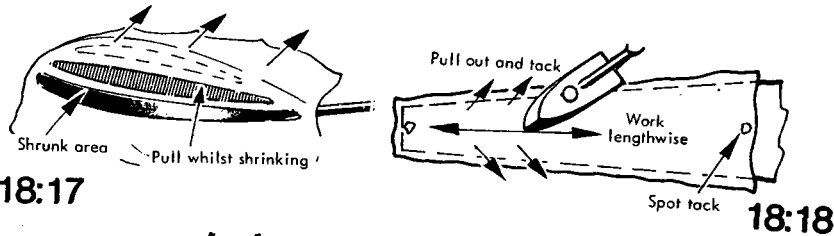

18:17

18:18

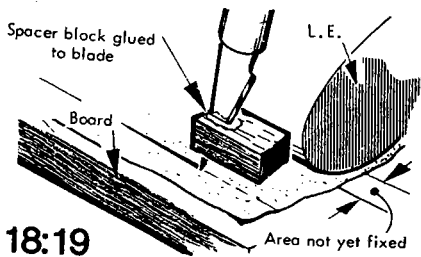

18:19

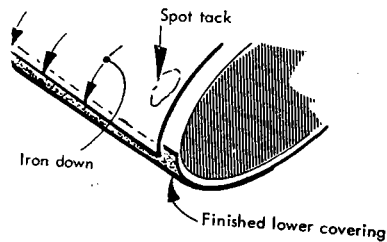

18:20

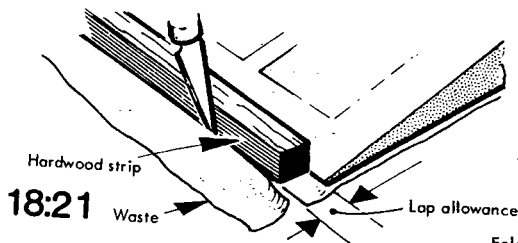

18:21

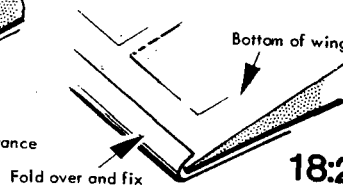

18:22

Cut the film as in 18:23, then guard the opposite edge with a piece of card as in 18:24. Concave areas like wing and tail fillets should be rubbed down firmly while hot, as in 18:25, otherwise it may shrink clear in a series of flats. To apply a contrasting colour, or to patch, adopt the method shown in 18:26.

### Preparation for painting

This procedure goes right back to the humble chuck glider. Any unprotected balsa will absorb moisture, get dirty and probably warp, if it is not protected with at least a few coats of clear dope. The sort of finish obtained depends on the initial surface preparation. For light sheet models, try this:

One coat clear dope, light sanding, 2 coats sanding sealer, sand really smooth, then one or two coats clear. The sealer fills the grain and the dope bonds the hairy bits of the surface together. Alternatively use one of the special modeller's acrylic primers for balsa: this seals and can be sanded ready for clear dope or painting. If the bare wood is given a coat of primer, any grain which would normally show under lightweight tissue should lie flat.

It is customary to cover bare wood with lightweight Modelspan prior to painting. This is applied either by the methods described earlier, or by brushing clear dope on, then after positioning the tissue, brushing more dope through it to bond it in place. Even thinners works if there is enough dope underneath. Primer can also be used, so can diluted SANDABLE P.V.A. glue. You now have a fairly smooth base . . . avoid over-sanding this, it will expose the wood.

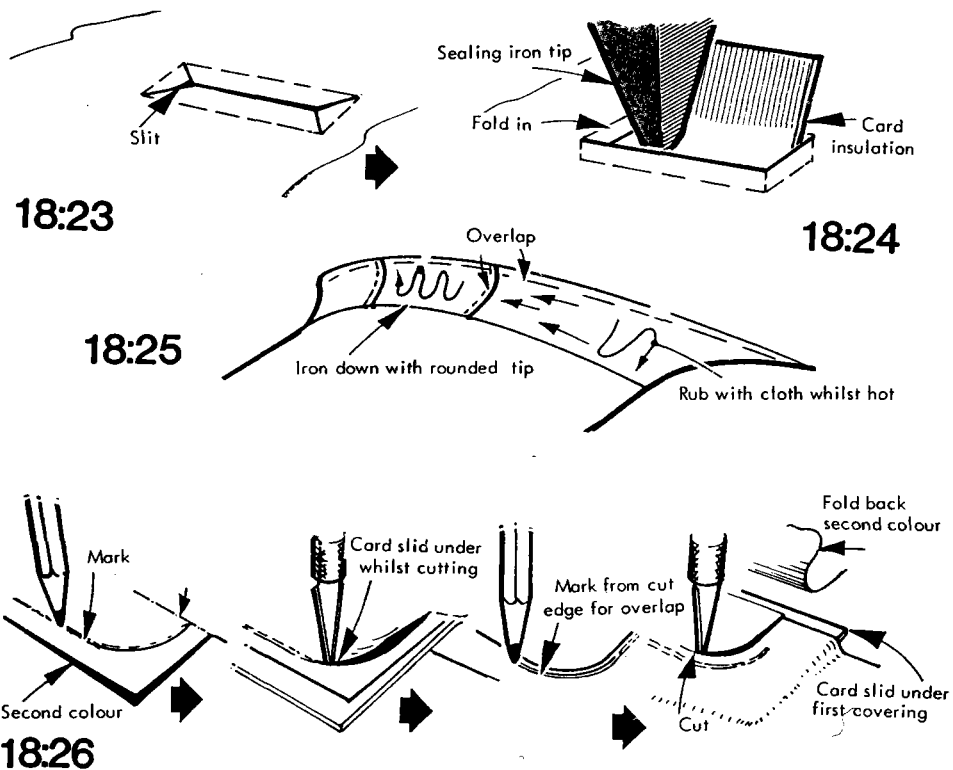

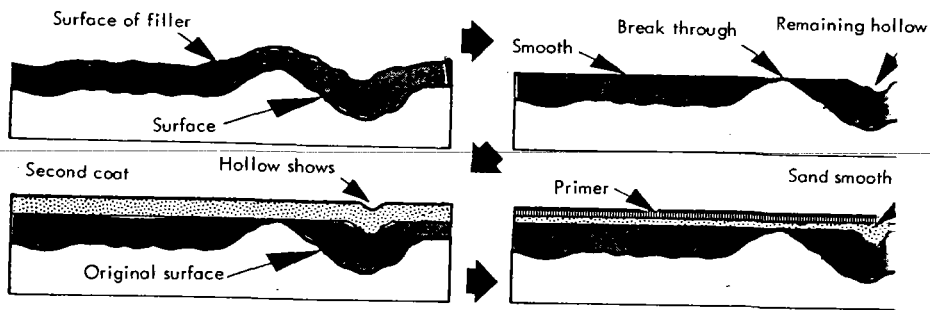

18:27

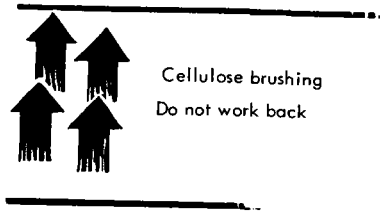

18:28

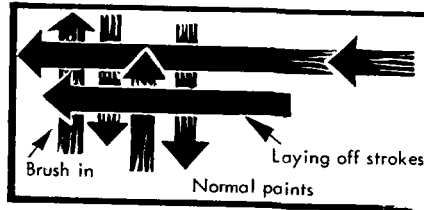

18:29

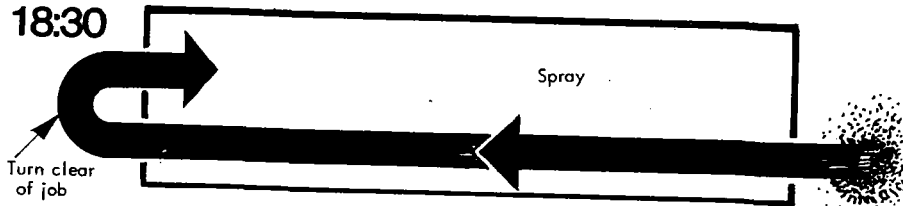

18:30

What follows can be done over nylon, silk or glassfibre cloth coverings but keep it away from bare foam (expanded polystyrene).

The filler is a mixture of polyester resin (and hardener) and micro balloons. The latter are an extremely light filler and look like white powder. Apply several thin coats with a brush or pad and sand really smooth. Re-coat any areas where the fabric or tissue is exposed and re-sand carefully. Micro Balloons mixed to a thick paste with polyester resin makes excellent fillets.

From then on, it is just a question of applying a cellulose or other primer compatible with the paint, sanding and going to it with the colours. 18:27 shows some magnified sections of the finish in progress.

### Brush or spray

Cellulose, the traditional model finish, is not as easy to apply by brush as other paints; it drags and picks up, if over-brushed. Just lay each stroke onto the last, once only and leave it as in 18:28. If you've painted the house well, you can paint on most of the other and fuel resistant paints sold for modelling. 18:29 explains.

Spraying depends on the type of spray gun or modeller's airbrush you have. Basically the paint needs to be thinned, most probably more than you think, until it sprays without giving a crumbly 'orange peel' finish. Of course spray cans are there at a price. In any event practise



first, start clear of the job, and move evenly, turning clear of the end whenever possible as in 18:30. For lining, a draughtsman's ruling pen can be used as in 18:31, filling in with brush or spray (after masking).

The draughtsman's rule pen can save a badly masked and sprayed area. Get crisp end and corners by masking for the pen as in 18:32.

Whenever doing any masking for spraying or brush painting, seal over the edges of the masking tape with the same colour as you are masking out . . . No, not the exposed area colour, the colour to be covered up. Got it? This seals the edges, and if any paint *does* run under the tape, it will be the same colour as the background, so it will not show. The new colour only gets as far as the masking tape edge

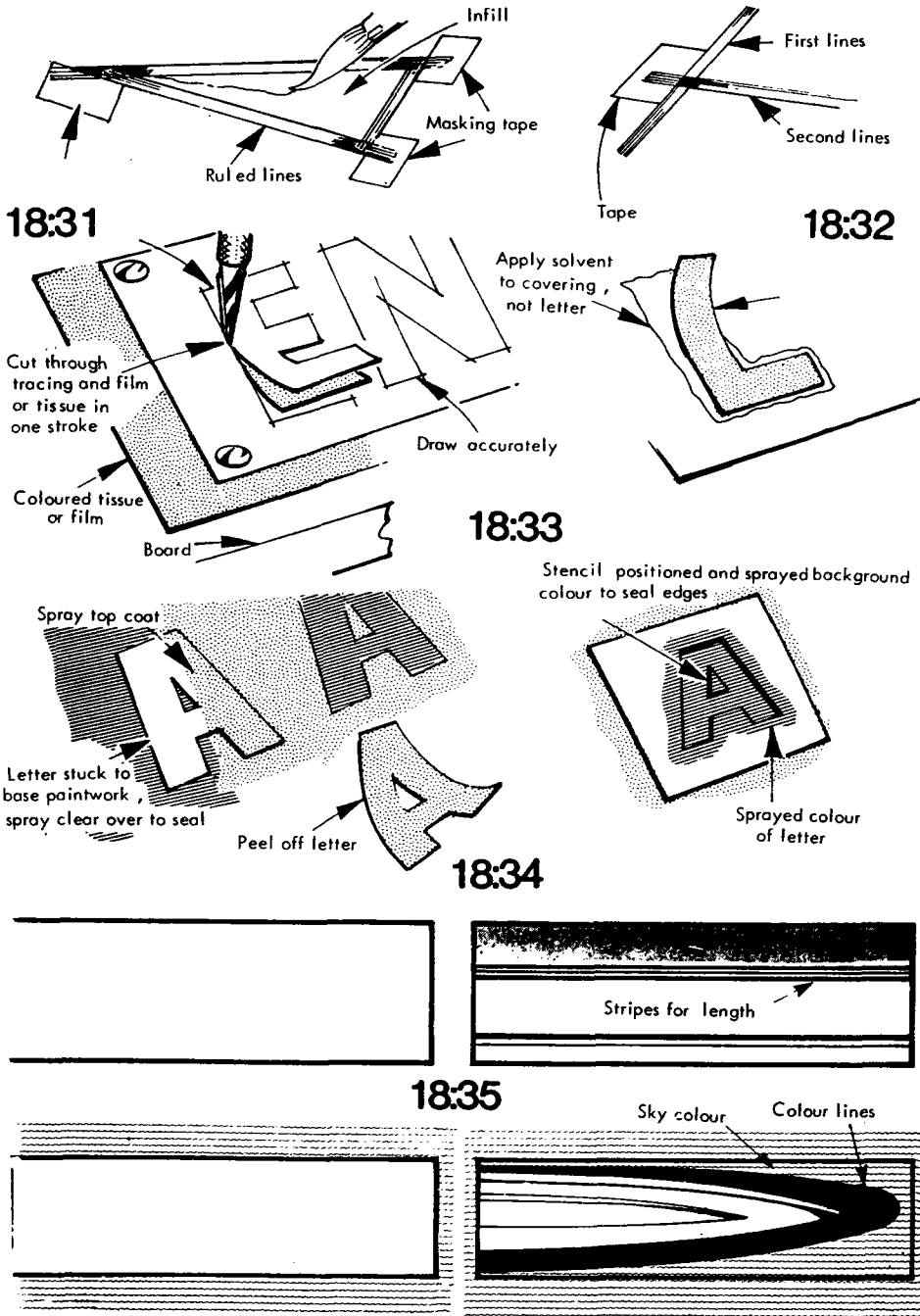

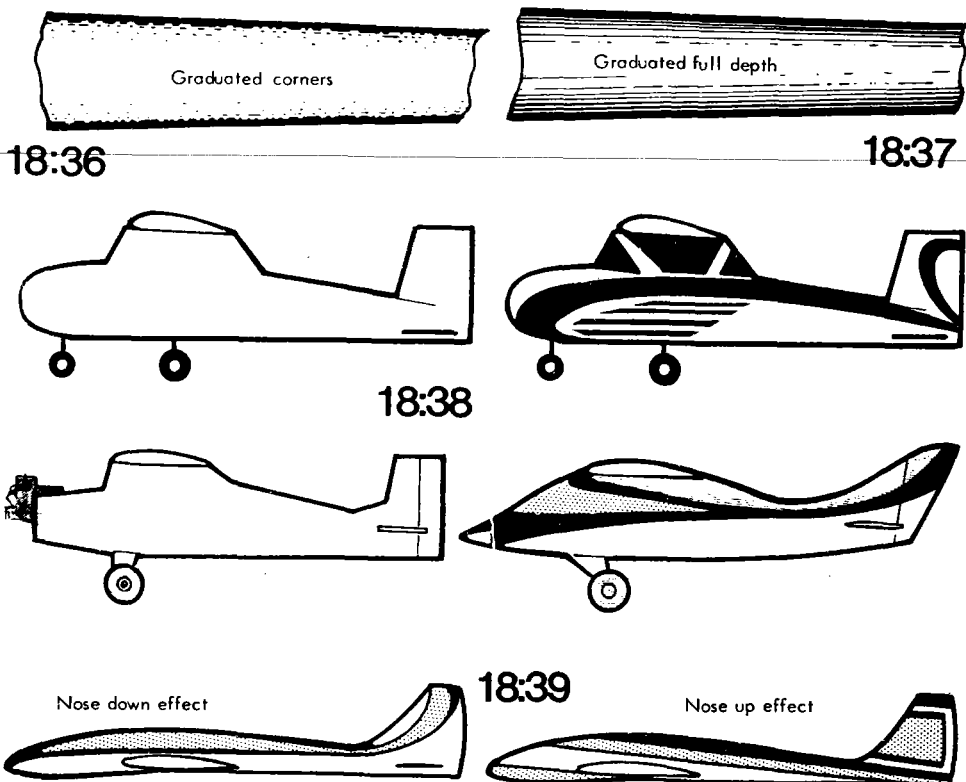

now sealed. Always put dark over light for better coverage and avoid incompatible colours: some even bleed their colour into the following one . . . test it first on a scrap or old model. Now let's do lettering and trims. Tissue lettering can be cut out as in 18:33, so can film. Dope on the former, apply solvent to the film surface before positioning the latter. Film can be slid around easily if a light smear of washing-up liquid is used. It dries out and avoids wrinkles – try it on decals too. Masked and stencilled letters appear in 18:34.

### Changing the appearance

Study the wings in 18:35 for inspiration, if the wing you have is not the shape you would have liked.

Fuselages too can be given the 'trompe l'oeuil' treatment, darkening the corners to give them the appearance of being rounded as in 18:36, or fully graduated to appear round or oval as in 18:37. A practised eye and handiness with an airbrush helps here. The rather stark fuselage side views in 18:38 have responded in part to colour scheme, but a slight modification without changing the flying characteristics would have combined with colour lines to give something better.

Given a reasonable shape, the attitude can be made to appear different by angling the colour scheme lines as in 18:39.

These notes have been brief, but derive inspiration from other models and full-size machines. It would be a sad world if models were uniform.

# CHAPTER 19

## Propellers for rubber power

**Pitch plotting**  
**Carving**  
**Folding blades**  
**Prop stops**

Some model plans give details of the 'blank' of balsa wood from which to carve the propeller of a rubber driven model. Others may specify a commercial equivalent in plastic, usually the smaller variety. Others merely specify diameter and pitch. How then does one establish the correct blade angles, which, it will be noticed from other examples, start steep at the hub and change to a flatter angle at the tip? Imagine any part of the prop blade making one complete revolution. The distance it will travel forward in that one turn is the pitch. Now it should be obvious from sketch 19:1 that if a piece of paper is rolled to make a tube of the tip diameter and cut to match the pitch length, a straight line

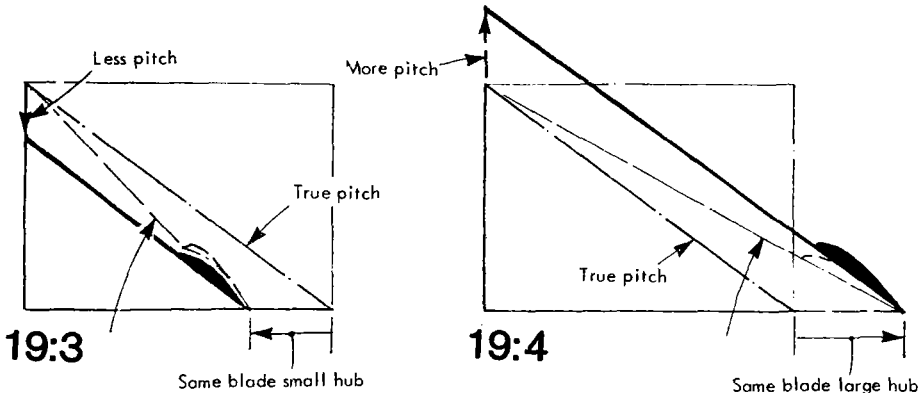
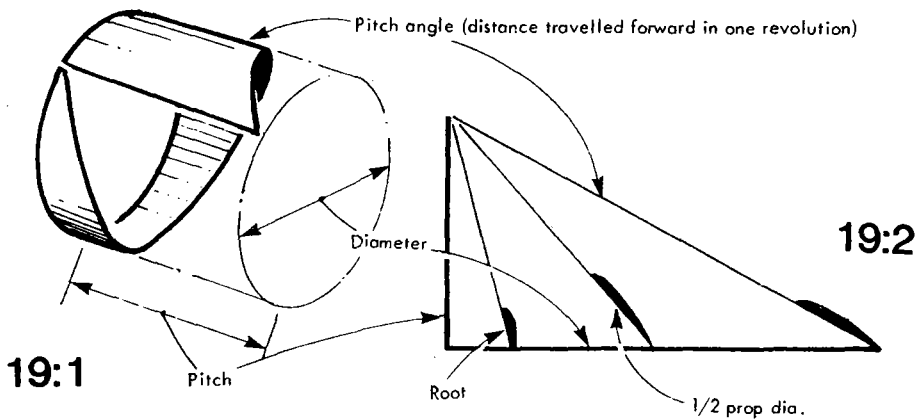

can be drawn from one corner to the diagonally opposite one when it unrolled and is laid flat. This is the pitch angle, as in 19:2. The pitch angle is thus a combination of circumference (not dia.) and length travelled (height). Some modellers may modify the pitch unknowingly when cutting a normal fixed blade prop to make a folding version. How much is lost or added by the hub will promote this change. 19:3 shows what happens when the hub is reduced and 19:4 when the hub is large.

Trimming the tips of the prop after enlarging it with an oversize hub will not reduce the extended pitch at all, so leave the tips alone and cut the root ends to accommodate the new hub.

A prop can be laminated from strips of balsa spread as in 19:5, using a line drawn from corner to corner at the tip to match the pitch angle (chosen and plotted on a strip of paper). Note how the centre of the laminations is reduced in width – this set-up is nearer to what is known as true geometric pitch, but for practical reasons, cannot be taken to zero at the centre. 19:6 shows a simple blank from one piece of balsa. Note how weak it is at the centre. 19:7 is deeper and has the ends thinned to bring the end to the correct proportions to suit the pitch angle. More refined is that in 19:8 where the hub is reduced a little to avoid the aerofoil section being too thick there. The tips are also reduced on both front and back as well as being tapered in side view.

19:5

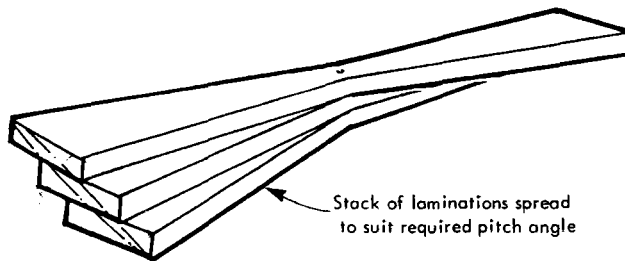

19:6

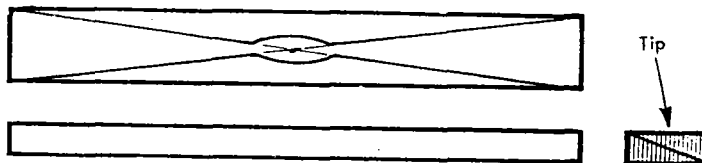

19:7

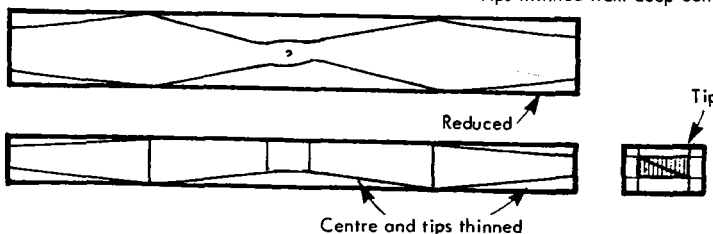
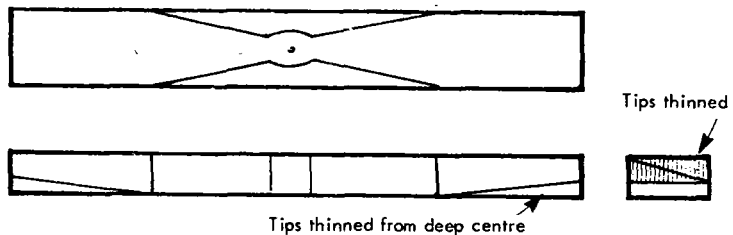

19:8

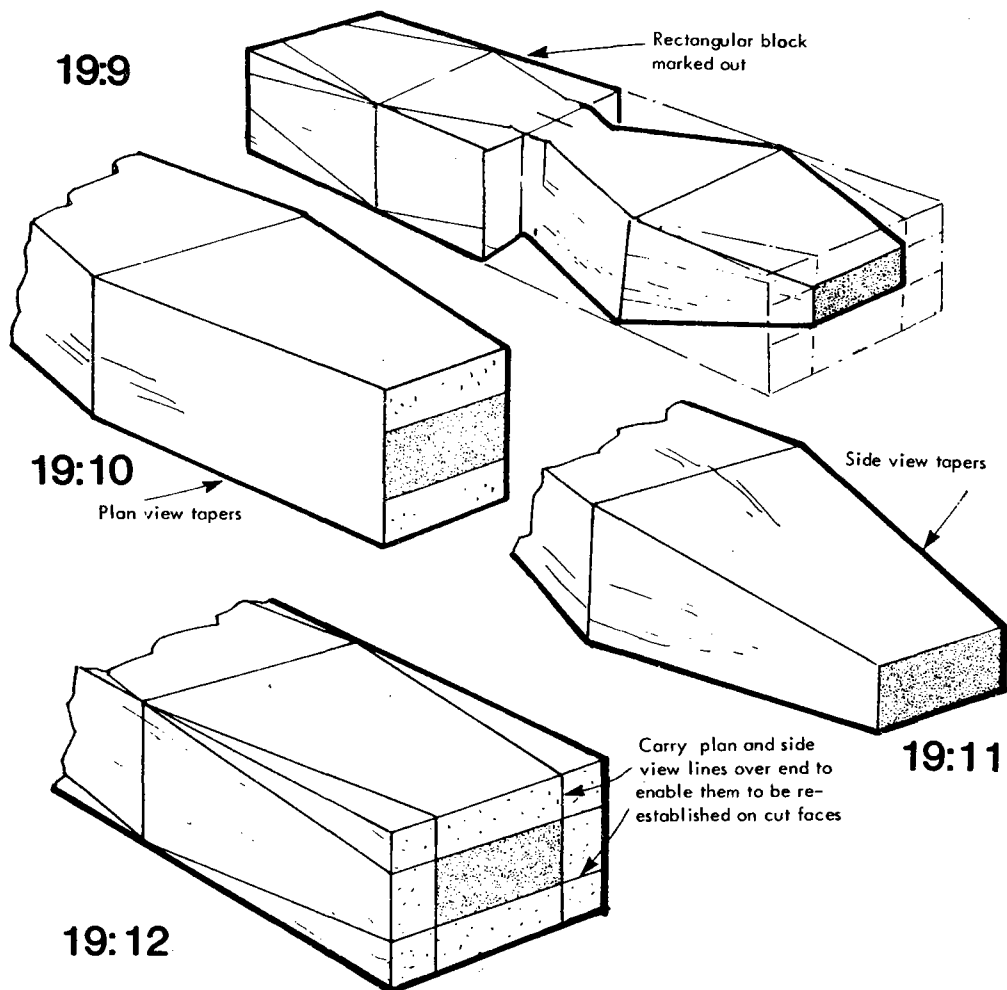

Now let's start carving. Remember that the prop usually rotates in a counter clockwise direction when viewed from the front. This means that from the back, the leading edge of each blade will be on the right and furthest forward. Twist a strip of paper in the fingers to prove this.

Mark the block out as in 19:9. The widest part is usually at mid-blade and the deeper the block, the higher will be the pitch for a given width. The angle of this diagonal can be checked from half the length of the base line (circumference) on the diagram in 19:2. This governs the overall cross section of the basic block. The tip angle can be marked on the ends, resulting in a rectangle (shown shaded). The initial cuts to taper the block, as enlarged in 19:10, will remove the guide lines, so to arrive at the shape in 19:11; it is wise to carry all lines over the ends, so that they can be re-drawn on the cut faces (19:10) prior to finishing the tapering.

The next step is to mark the back and front faces for reference near the centre. The first part of carving proper is the flat back surface of each blade, which goes from corner to corner. Remember too, which is the leading edge.

Some of the hard work can be reduced by making several sawcuts with a fine tooth saw (junior hacksaw) as seen in 19:13. Cutting away

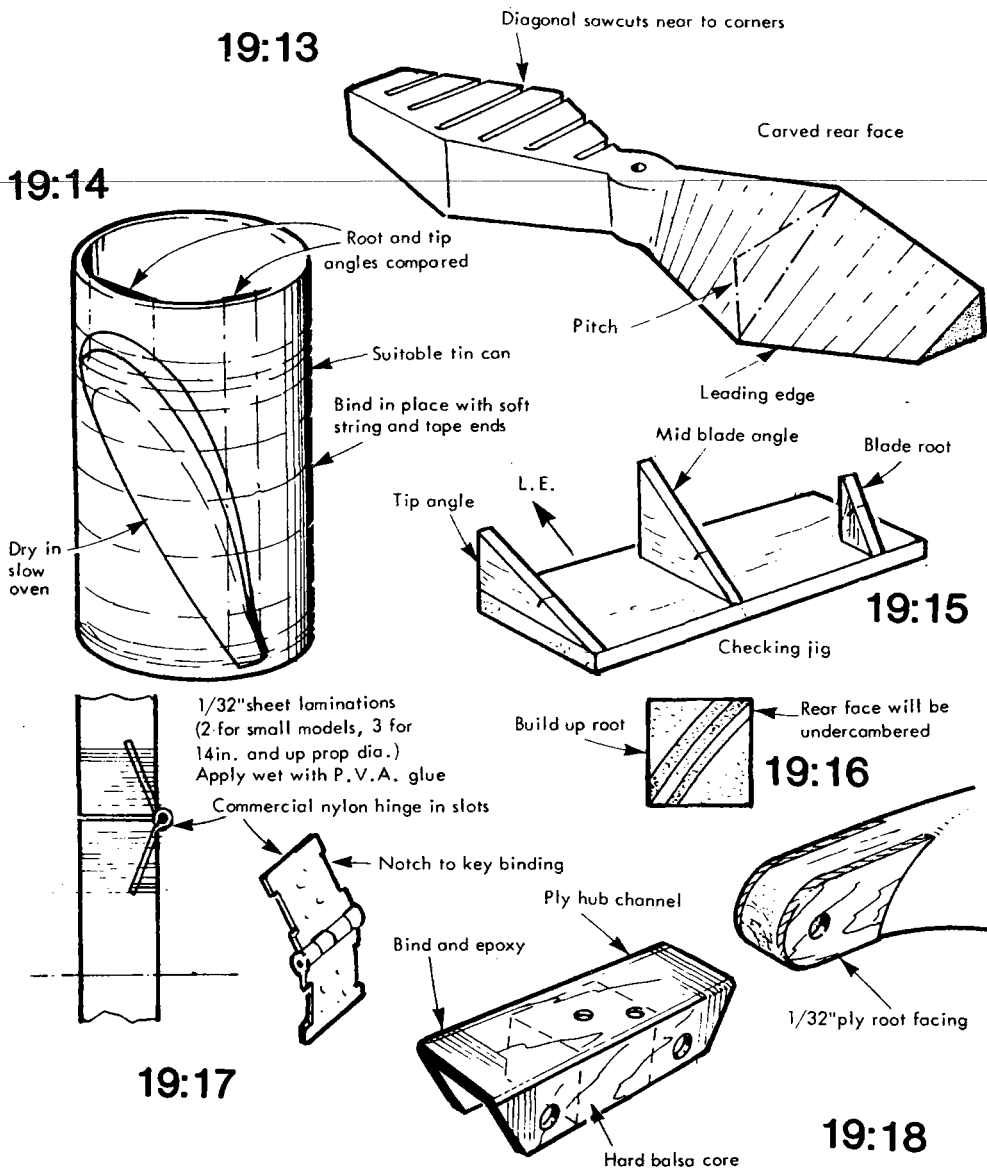

the intervening wood with a wide bladed penknife produces a flat but helical surface. The opposite surface is then carved away to an aerofoil section, thickening towards the hub for strength. A slight undercamber can then be sanded on the rear faces, checking with card templates and calipers and by holding up to a bright light, to obtain a similar thickness and balance on each blade. The shaft hole is best made before the fronts of the blades are carved.

### Moulded props

A quick and economical method, if not as accurate, is to obtain a suitable tin can, old saucepan, or stoneware jar for use as a forme. Work out the relative tip and root angles of the prop blade (these blades are usually intended for folder props).

Take tangents to the surface of the forme and position laminations as in 19:14.

Check the finished blade on a jig derived from sketch 19:2 as in 19:15 and build up the roots with triangular strip, re-sanded to set the root at the correct angle (19:16). Blade hingeing can be simple for small props, thanks to R/C hinges (19:17), or more substantial as in 19:18.

Other hubs are shown, e.g. 19:19, which has to be assembled around the blade roots. Note how the root matches the hub section for ease of setting up the correct angles of pitch and true running of each blade. That hub has to be wide enough to allow the blades to lie close to the fuselage when folded. If it is too short the blade tips will stick out and produce drag. Too wide and the blades will not fair in neatly.

Sketch 19:20 shows a piece of ali tube slit and bent to form a hub. The blades can be shod with tube of the next size down, or bound with glass cloth and epoxied. 10BA bolts can be used as hinge pins (19:21).

Some designs have single bladed props, the blade being balanced by a counterweight which can be bent back slightly to obtain smooth running under power. Sketch 19:22 shows this. The blade can be retained by a fine wire 'keeper' or piece of plastic tube pushed onto the wire hinge pin. The pin faces the direction of rotation, for safety.

A double blade version has a separate hinge arm bound and soldered to the shaft after the latter has been formed to make a loop (19:23).

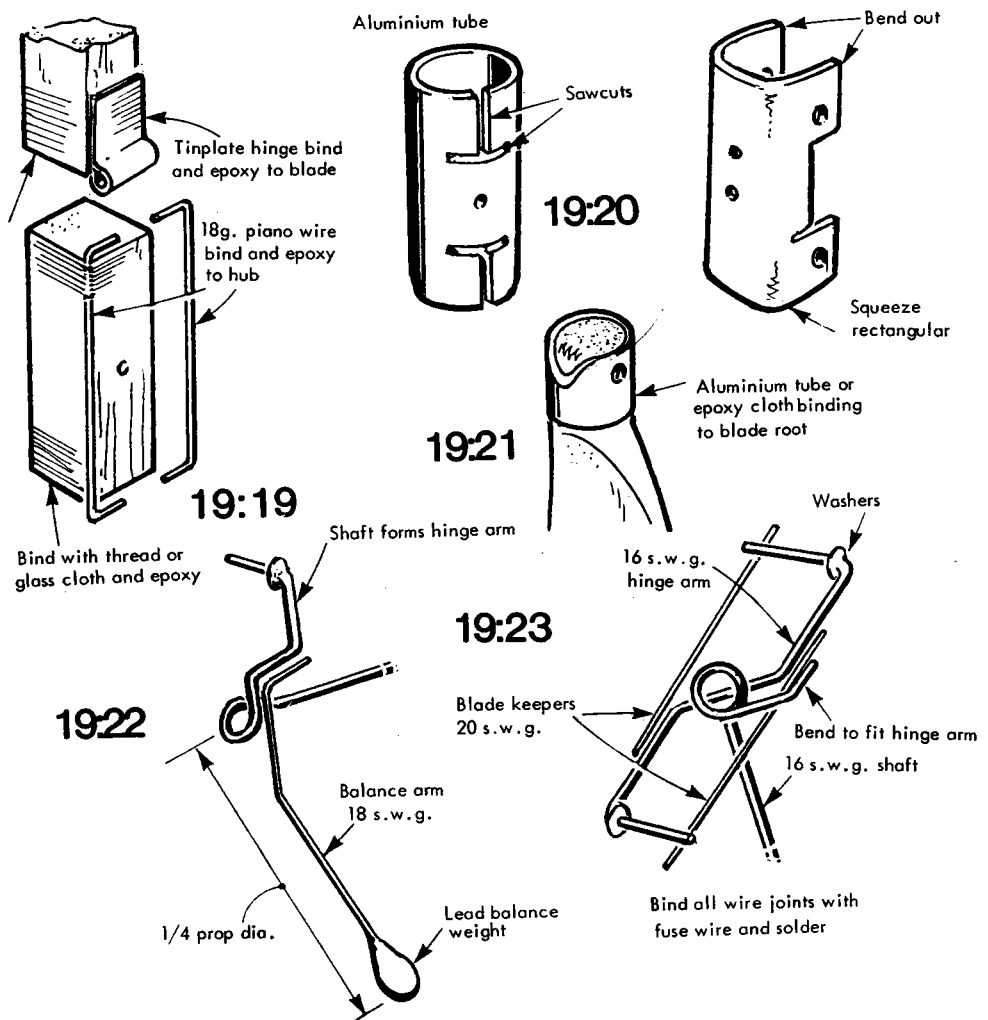

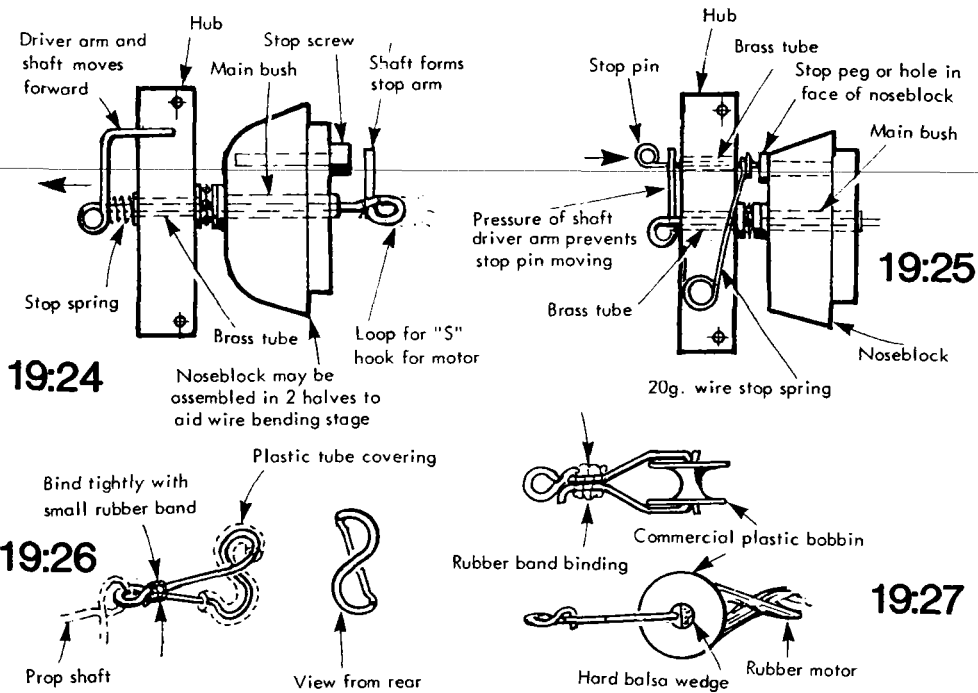

In both these examples the blade roots have wire pins to rest against the centre of the hinge arm to prevent the blades leaning forward.

Earlier models had free-wheeling propellers, but these produced more drag when the motor run was ended. The windmilling blades promoted unwanted turbulence. A few models had feathering blades, but this was considered an unwanted complication. Some of today's experts have devised variable pitch props to take advantage of the varying strength of the motor as it runs down; these may also fold.

What *is* important is the need to stop the propeller rotating at the end of the useful power run, so that it can always fold at the same position, so preserving the glide trim. Most systems rely on a spring overcoming the pull of the now slackened rubber motor. 19:24 shows a traditional method, where the shaft is pulled forward.

More effective is the 'Montreal' stop. This has a stop pin which is spring loaded to slide back and engage on a peg or drop into a hole in the noseblock. Sketch 19:25 shows the construction. The pin is pulled forward after winding the motor and the pressure of the shaft's driving arm, which might normally be placed on the hub, jams the pin so that it cannot slide back until the power is exhausted and its hold relaxed. The shaft does not have to slide, so there is less chance of it bending or upsetting the balance.

The motor can be carried by a wire 'S' hook covered in plastic tube to prevent it cutting, as in 19:26, or taken over a plastic bobbin on an 'S' hook. The advantage is that the motor runs true and can be wound without the propeller assembly. Hook the latter on before freeing the winder though! (19:27). Small models can just have a plain hook on the shaft, protected with plastic tube.



# CHAPTER 20

## Linkage tips

**Control line  
Radio control  
Free flight**

One of the prime requirements for reliability in control-line models is the correct mounting of the control bellcrank. Not only does this have to be securely mounted, so that the model/control-line link withstands many times the 'G' force exerted by the model without failing, but so that the bellcrank is free to pivot easily and without slop, to ensure that the control is positive at all times.

A basic bellcrank shape is seen in sketch 20:1 and is typical. Note how the distance between the pushrod and pivot is less than the distance between the control lines and the pivot. Sometimes there is the option of using an alternative pushrod hole to make this difference more pronounced.

When the bellcrank is mounted on a bolt, a piece of brass tube should be used to form a smooth bearing, as in 20:2, rather than allowing the bellcrank to run on the bolt thread, where it would soon wear to a sloppy fit.

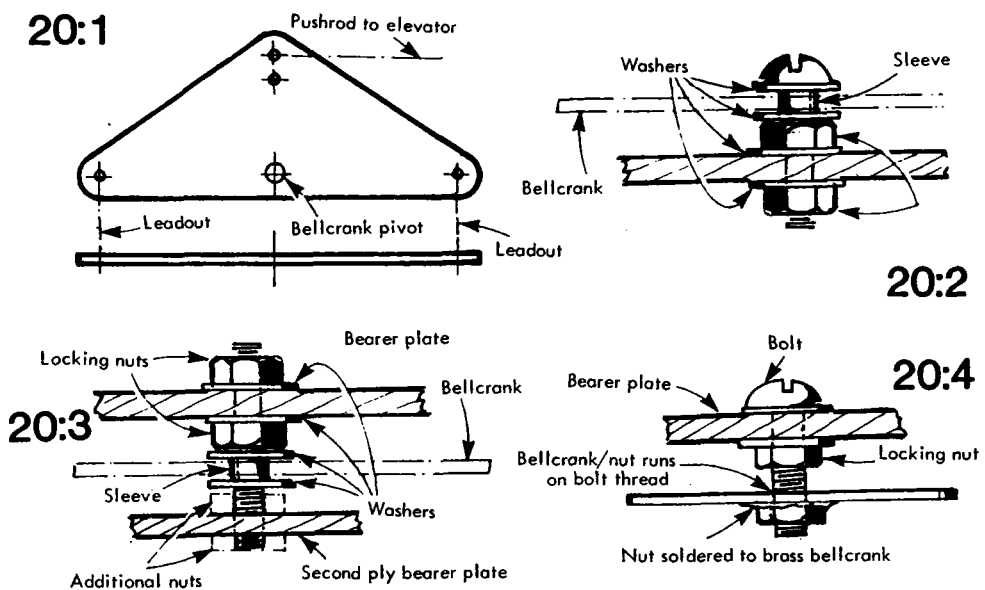

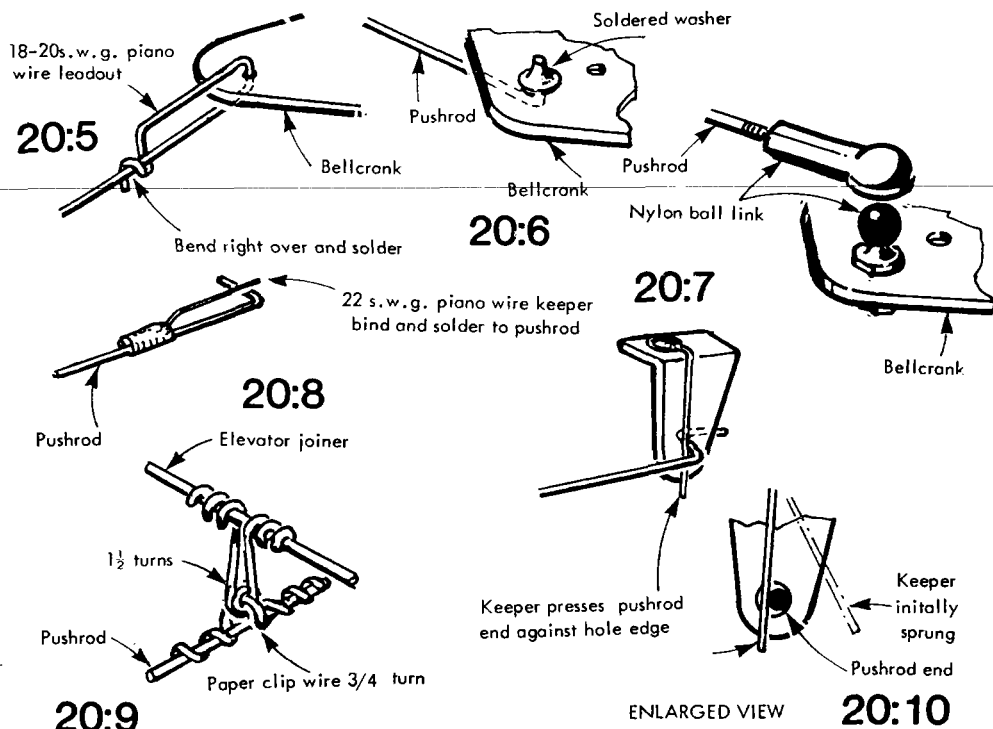

Sketch 20:3 shows an extra ply mounting plate for better security, not forgetting the bearing sleeve of course. Sketch 20:4 shows how a brass or steel bellcrank can be soldered to a nut, so that it has a better bearing surface on the bolt. The fact that the bellcrank will rise and fall fractionally on the thread is insignificant compared with the advantages of being self-retaining and matched to its bearing surface.

The wires which come from the bellcrank to connect with the control lines themselves are called 'leadouts'. Where these are of thin piano wire, the connection can be made as seen in sketch 20:5. Yes, the wire will wear the hole in prolonged use, but as the leadouts and control lines are under tension in flight, the result will not be sloppy control. Holes in the bellcrank can be bushed with scraps of brass tube, soldered if the bellcrank is steel or brass, but if it is aluminium alloy or dural, the bushes should be riveted over at each end to secure them. Some modellers fit a pop rivet and drill it to suit the wire.

The elevator pushrod can be retained by soldering a washer when in situ, as in 20:6. A more workman-like job is made by using a commercial ball link (often adjustable) as sold in model car or radio control departments of the model shop (20:7). The other end of the pushrod can be retained in the elevator horn by fitting it with a 'keeper' wire as in sketch 20:8. Control horns were discussed earlier in Chapter 10, but bear in mind that the wire pushrod end should be a smooth, slop-free fit in the horn hole(s). Where space does not permit conventional horn and pushrod linkage arrangement, the bent wire system may be used, scaled up or down to suit the type of model – see 20:9. The elevator horn may wear after protracted use which will introduce sloppiness into the system; sketch 20:10 offers a solution.

Vibration can also cause the leadout wires, running within the wing, to wear pieces of the wing ribs away, resulting in a wing that contains 'confetti' and shows up badly when tissue or clear fabric doped. Scraps of Paxolin will provide wear-resistant guides as in 20:11. The same method is useful on aileron pushrods in radio control models. At the wingtip, leadouts can be supported in the correct position by a wire guide which serves to position external leadouts as seen in 20:12.

Internal leadouts can exit through the wingtip via brass tubes.

The fore and aft position of the leadouts can be adjusted to obtain the best attitude of the model in relation to its lines (i.e. nose-out or nose-in to the true tangent that it makes with the flight circle). The method shown in 20:13 should enable the model to be correctly set-up. Rounded blocks can be fitted, slotted and hollowed on the line-side tip.

### Coupled flaps

Stunt control line models can benefit from the use of large trailing edge flaps on the wings, arranged to go in the opposite direction to the elevator, so that the model derives extra lift to help it around sharp

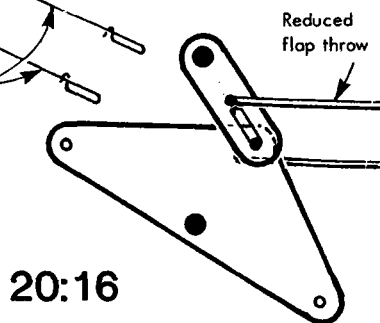
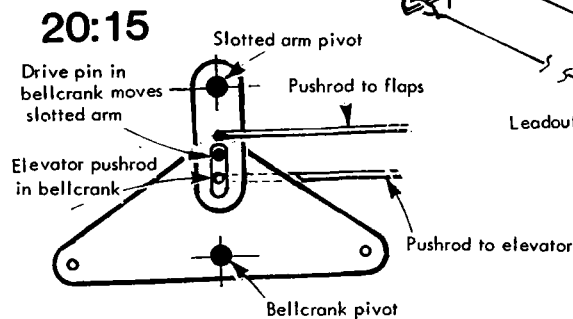
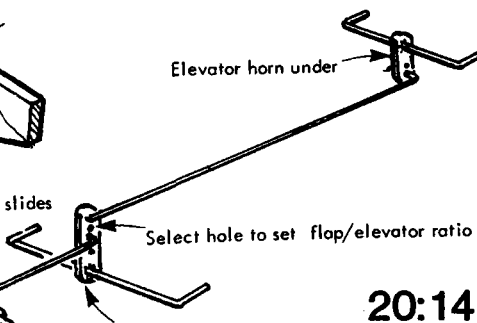
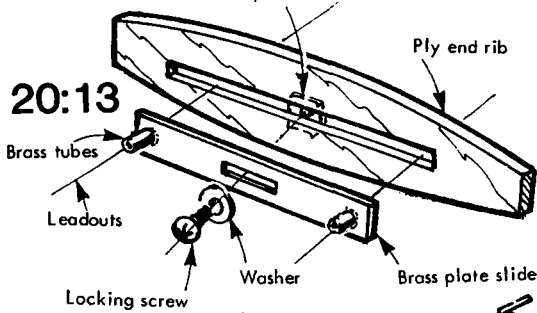
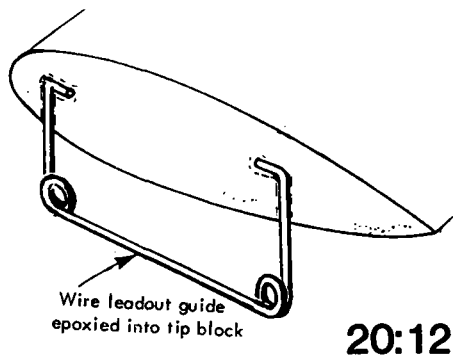
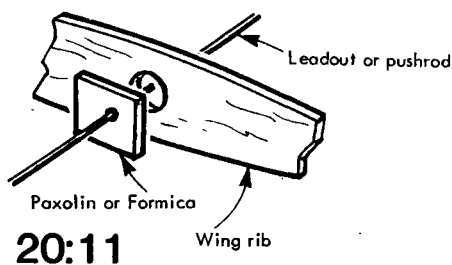

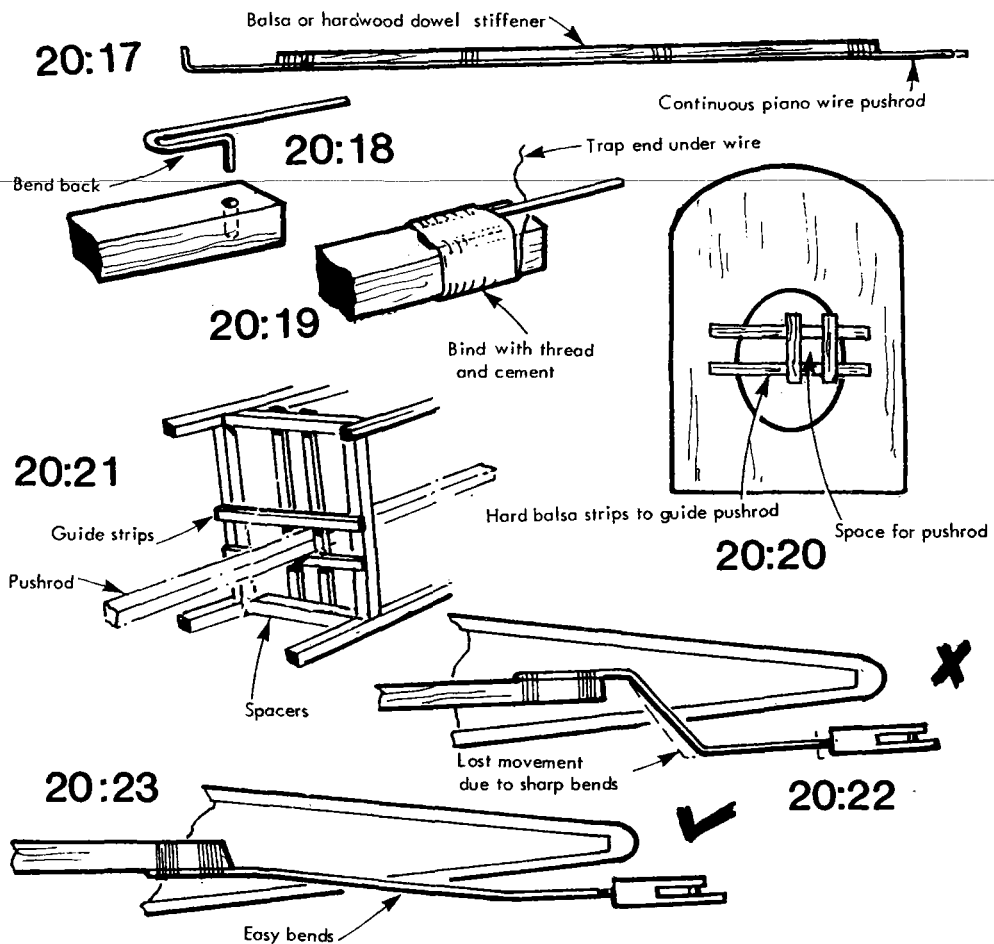

manoeuvres. It is usual to have the flaps moving through a smaller arc than the elevators, and the linkage seen in 20:14 is typical.

To avoid excess flap angle at maximum elevator throw, while giving plenty near neutral, a more complex linkage can be used; 20:15 explains. Compare the relative moments with 20:16.

Pushrods which bend will reduce effectiveness. Wire pushrods on C/L models can be stiffened with a strip of wood as in 20:17. Where the pushrod is wood, with separate wire ends, as is often seen on radio control linkages, the firm joining of wire to wood is important. 20:18 shows an improved wire bend to prevent uneven seating of the wire.

Finishing off with thread binding and epoxy or even balsa cement can be done as in 20:19. Heat-shrink sleeving can be used if tight.

It is often convenient to make large cut-outs in fuselage formers for installation of the pushrod, then when set, up guides can be added as in 20:20. Open frame fuselages can be given guides in a similar manner, see 20:21. Be sure to allow clearance for the pushrod(s) to move laterally to accommodate the movement of the bellcrank or servo.

Pushrods should always go in as direct a line as possible. If the fuselage dictates a crank in the line, the wire part will most probably bend and lose movement (20:22). Note how in 20:23 the wire is on the outer side of the rod and bends are minimal.

Tube and cable linkages (sometimes called 'snakes') are a convenient means of linkage in R/C models, but make sure that the tube or cable outer sleeve is secure, either by gluing it to the fuselage side at intervals or to the formers. Avoid unnecessary bends in the cable (it stiffens up the movement) and be sure to fix it at both ends, otherwise the inner will try to stay still and the outer creep fore and aft.

Sketch 20:24 gives some guide-lines.

Builders of contest R/C gliders have on occasions found that a plastic fuselage boom or the fuselage itself had a different coefficient of expansion to that of the control pushrod to elevator or rudder. This gave unwanted control neutral shift when the model was in hot or extra cold conditions. An answer to this can be seen in 20:25. Here, the servo is supported on a 'return pushrod' of the same material as the pushrod itself, thus the fuselage is independent of the system and the 'return pushrod' and pushrod expand at the same rate, resulting in zero neutral change. Note that the servo is not firmly attached to the fuselage, so the latter can move as much as it likes.

### Auto rudder

Free flight models may also need linkages, the simplest of which is the auto rudder on towline gliders. The purpose is to keep the tow straight, then change to circling flight on casting off the towline. There are various methods, of which that in 20:26 is typical. It does not

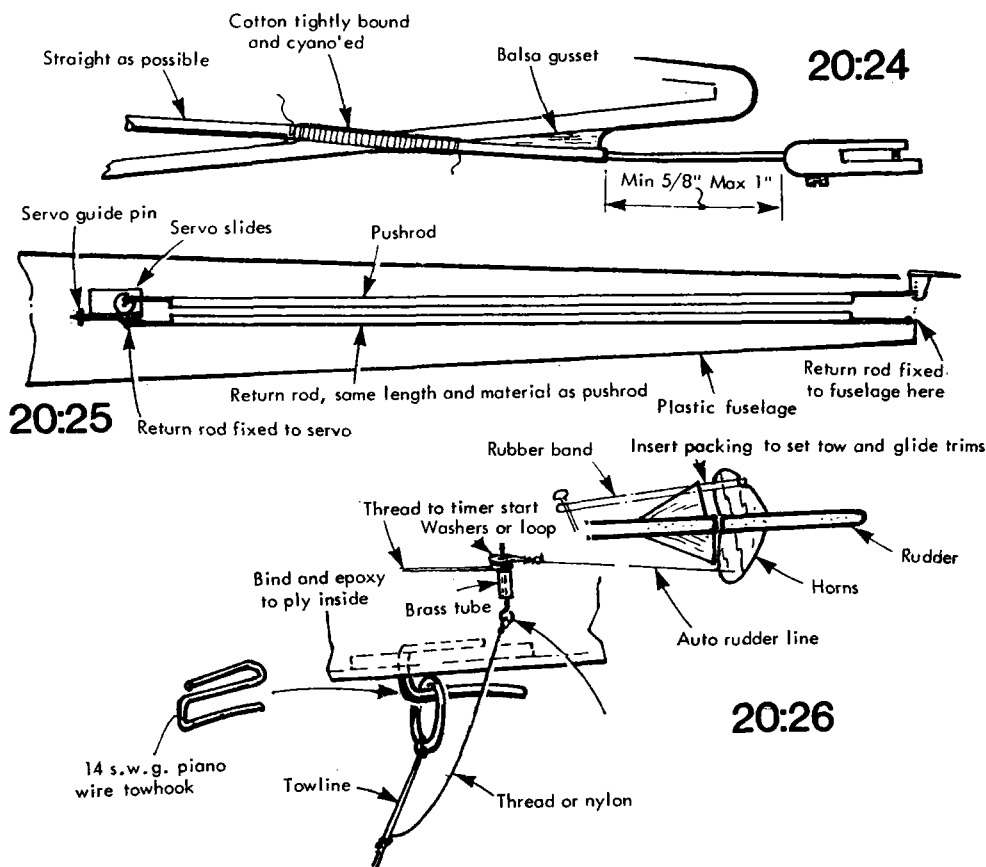

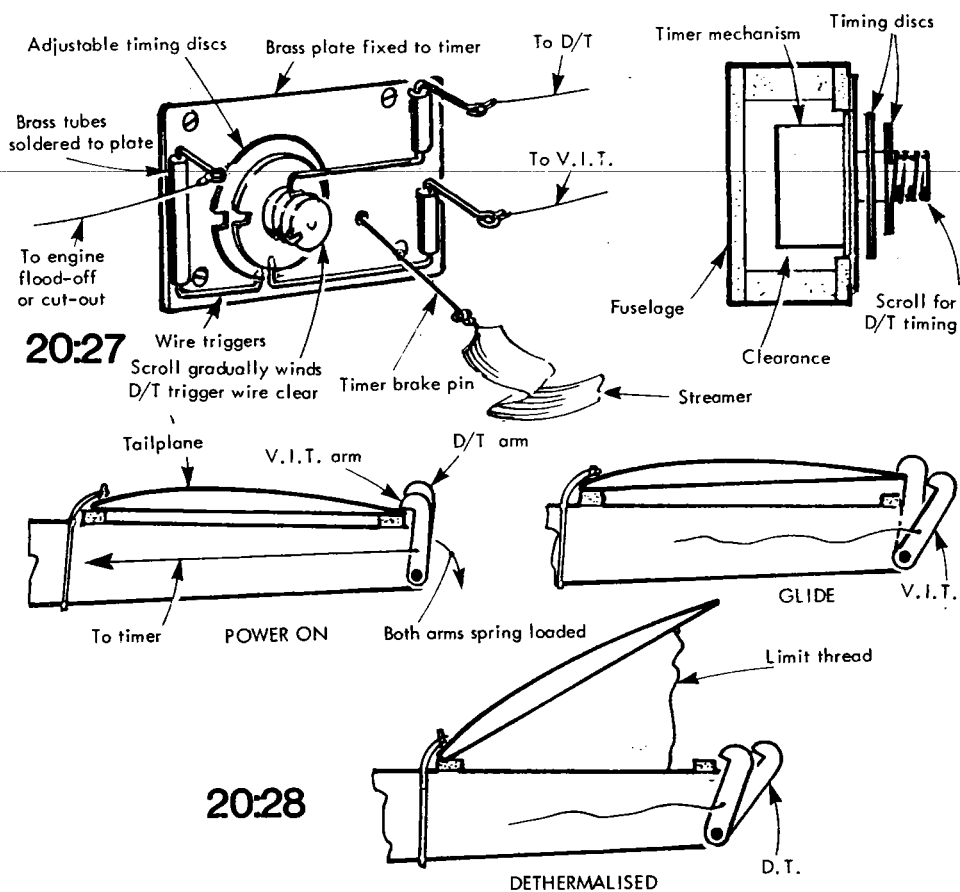

impose a load on the linkage whilst towing and if the flight is to be limited by a clockwork timer ('dethermaliser' or D/T), the timer does not start until the model is free of the line, when the flight is officially begun.

Contest power models need a timer to cut the engine as required by the contest rules. Earlier machines relied haphazardly on a limited amount of fuel, but the sure way is to use a clockwork timer specially made for the purpose. These timers also have the facility for 'D/T' as well. Contest modellers have devised various methods of changing the flight trim during the power-on climb. The timer is made to first cut the engine, either by flooding fuel into the carb, or by breaking the supply. Almost immediately the tailplane changes to a negative incidence and sometimes the rudder setting is changed too; finally, much later, the tailplane is allowed to pop up into a steep negative angle for D/T action. There are many permutations of mechanical triggering to arrange this sequence, referred to as V.I.T. (variable incidence tail). It is stressed that these systems are for the contest experts, requiring 100% reliability of the engine and skill in launching, otherwise the model will probably wreck itself.

Sketch 20:27 shows just one of many methods of making one timer perform the sequence and 20:28 the tail end release mechanism of V.I.T. and D.T..

# CHAPTER 21

## Rigging and checking

**Truing up**  
**Balance**  
**Control surface check**  
**Rigging aids**

If a model has been assembled with its flying surfaces misaligned or if those surfaces are warped, then its performance will be poor or it may even be impossible to trim for proper flight. First an 'eyeball check' ... Look at the model head-on. Hopefully it does not appear as in sketch 21:1. Remember what was noted in Chapter 2 regarding washout and wash-in and its appearance. If at first sight the model seems to be quite true, align it with a known level line behind it, such as the edge of the ceiling or windowsill. Tilt the nose up or down to check the tail in relation to the wings, as in 21:2, though this will not show that the fuselage is misaligned to both.

Some free flight models are designed with deliberate variations in alignment, for example, the tailplane of a rubber powered duration model or a contest power model, may be tilted in relation to the wing to promote a natural turn, as seen in sketch 21:3. Such models have the

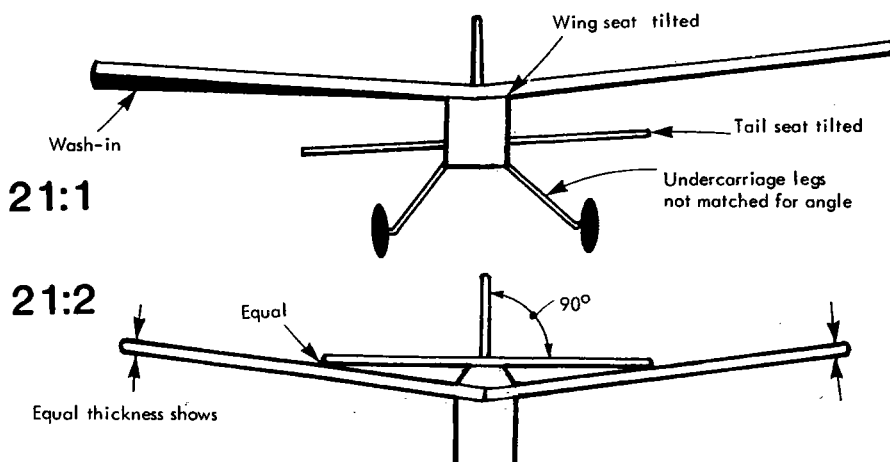

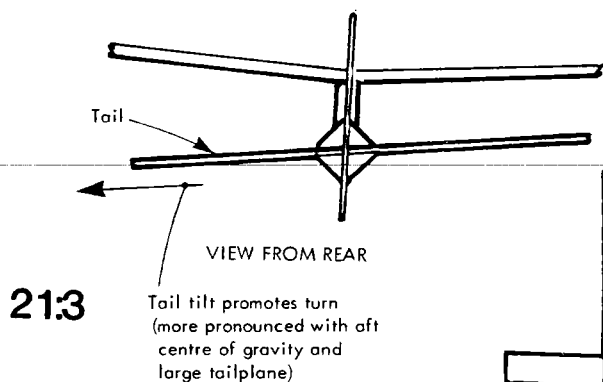

Tail tilt promotes turn  
(more pronounced with aft  
centre of gravity and  
large tailplane)

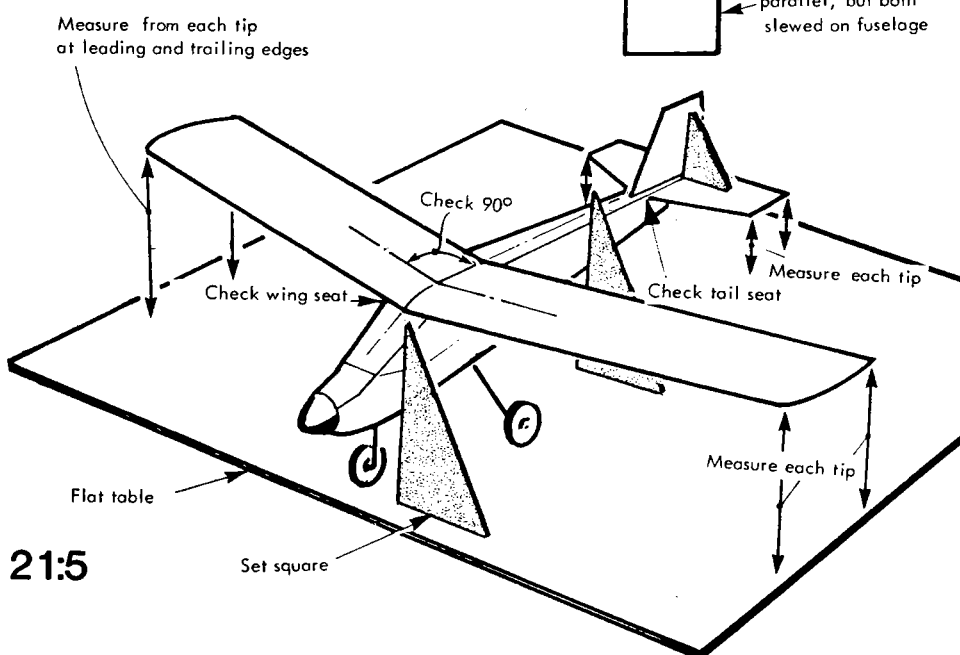
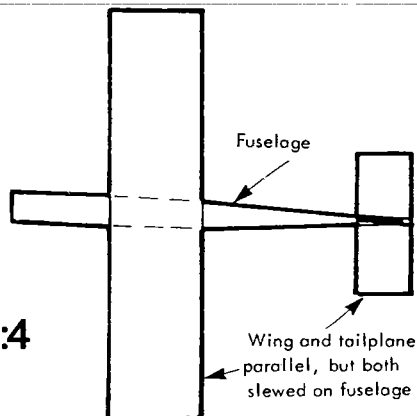

balance point far aft on the wing, consequently the tail is made to support more of the weight. Being tilted, the tail end 'slides downhill' towards the low tip, producing a turn without undue bank. On a radio controlled model, this would lead to inconsistency, as the tail is made to produce lift and anti-lift according to what pitch control is given. The tilt would cause turn in either direction when it was not wanted.

Turn can also be accidentally introduced by slewing the wing, tail or fuselage as in 21:4. In this particular sketch wing and tail are parallel, but the fuselage is misaligned. This model will probably bank left and try to turn right!

If the model is placed on a truly level and flat table, measurements may be checked as shown in 21:5 and card or draughtsman's set-squares, or carpenter's squares, used to align fuselage and fin. Datum and centre lines can be marked with a chinagraph pencil as a means of reference.



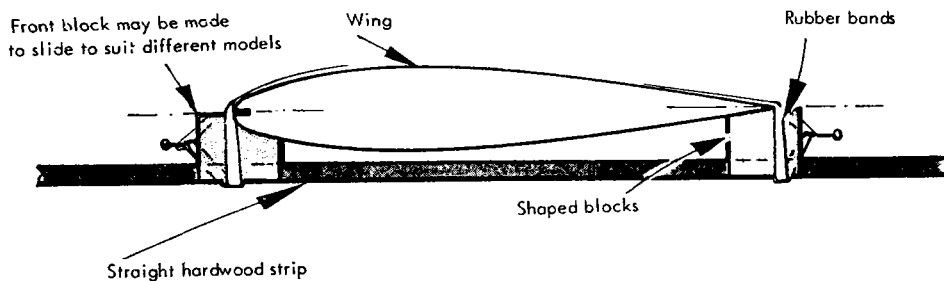

21:6

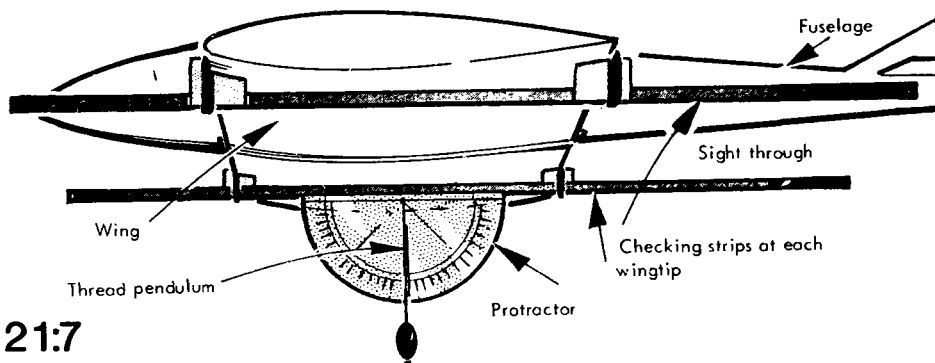

21:7

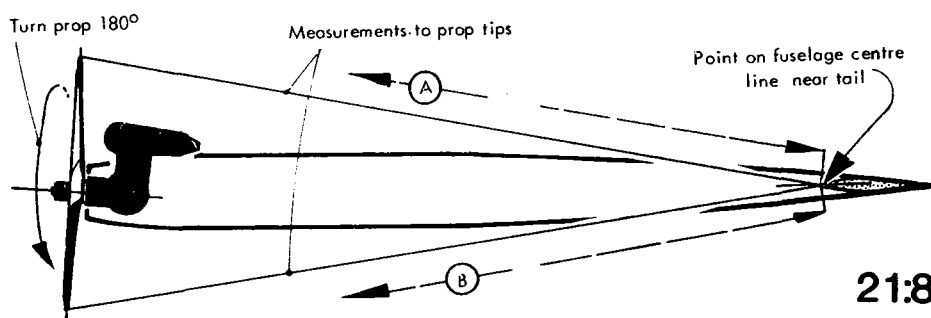

21:8

Such a test will establish whether or not the wing seats level, that the tips have the same amount of washout and the tail is similarly set up. To check the wing and tail seatings on the fuselage, lay strips of straight wood (1/4 in. sq. or so) across at leading and trailing edges and measure down from the tip of each to the table. Left and right tips of each strip should be the same distance. If, say, the tail is also at zero incidence and the fuselage has its datum parallel to the table as set up, then all the tail strips should be equidistant from the table.

Flat-bottomed wings and tails are relatively easy to check for warps and washout, so are those which are undercambered, but bi-convex or symmetrical flying surfaces need an artificial 'datum' line that can be seen. Sketch 21:6 shows sighting or measuring strips made from straight spruce or hard balsa and fitted with one fixed block and one sliding block which may be set to rest under or over the wing or tail leading edge and trailing edge respectively. Packing can be introduced to bring the checking strip exactly parallel to the wing datum. Usually a comparative check is sufficient. Sketch 21:7 shows how a second strip may be used to check the wing. Move the strips out equally on each

wing, for checking equal amounts of washout. Now place one at the root and move the other out progressively to check the amount and commencement of washout or to detect wash-in. Either strip may be aligned with the fuselage datum line to check incidence angles and the protractor/plumb-bob provide a point-by-point angular check of fuselage, wings and tail. Needless to say, the model should remain packed up for all these checks, which relate each part to the other.

Sketch 21:8 shows how to check side or downthrust in a conventional fuselage. Remember that engines behind the C.G. need opposite offset. The closer a motor is to the C.G. the less effective is the offset, but the more effective is its height above or below that point.

Balancing the model in accordance to the designed Centre of Gravity point is easy enough with the conventional high wing layout as in 21:9. Support the model on the fingertips or on blunt dowels against a convenient rib each side of the fuselage. It should sit level. Balance

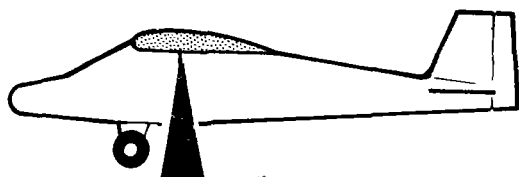

Balance with fuselage horizontal

21:9

21:10

Low wing model inverted to balance

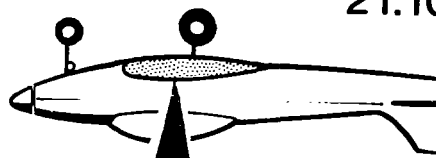

21:11

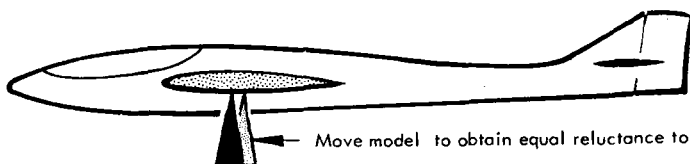

Move model to obtain equal reluctance to tilt

21:12

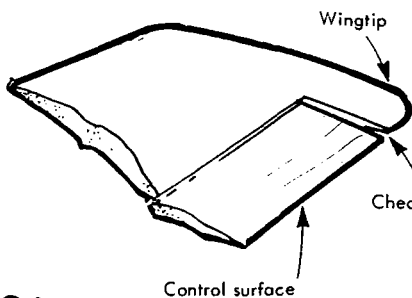

Control surface

21:13

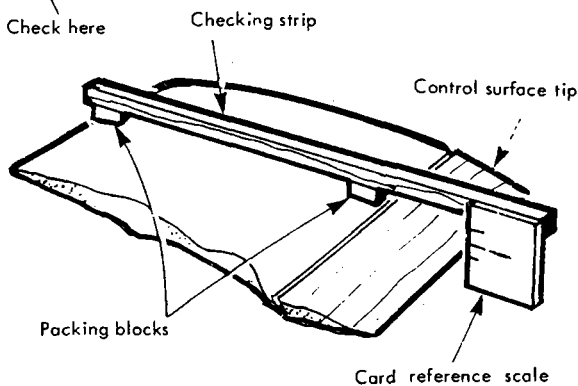

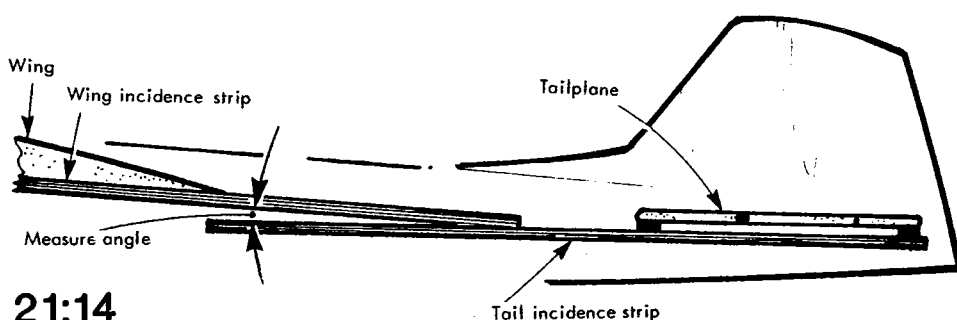

points are shown variously on plans as a chequered circle or arrow head. Mark the edge of the wing seat on the finished model, having drawn a line vertically from the point shown on the plan. A low wing model can be balanced upside-down as in 21:10, but those mid-wing models need to be moved fore and aft over the balancing supports until they tilt either way with equal ease. (21:11).

Remember that the balance test is *not* to establish a *new* balance point, but to show the need to add weight to the nose or tail to ensure that the model balances where it is designed to.

### Checking control neutrals

Some designs have wing and tail tips which extend to cover the ends of the control surfaces – see sketch 21:12. The tip can thus be used to align the trailing edge of aileron, elevator or rudder. If, however, as is quite common, the control surface goes right to the tip, a miniature version of the wing check strip can be used. This time, the support block sits just forward of the hinge line. A card reference scale can be added as seen in 21:13.

All-moving tails are not so easy to check, so mark the fuselage or fin carefully from the plan and align with a pin in leading and trailing edge of the moving tail.

The checking strip can also be used to show up small angular differences against the fuselage (or a point above it in 'T' tail layouts). Sketch 21:14 shows how a checking strip from the wing and one from the all-moving tail can be combined to give a reference angle, which can be compared with the drawings. In fact the checking strip method is one of the few methods which enable the more recent method of 'wing twist control' to be set up. Here the wings twist in opposition to each other for bank and together in opposition to a FIXED tailplane for pitch control.

# CHAPTER 22

## Minor repairs

- Dents in block
- Repair doublers
- Sheet patches
- Lightweight treatment
- Tissue tips

Balsa block areas which may have been dented can sometimes be returned to near normal shape by applying water, which swells the compressed fibres again. On drying, the surface may then only need re-finishing. Splits, however, can benefit from a ply or hard balsa 'stitch' inserted into a transverse sawcut as in sketch 22:1. Small cracks can be dealt with by a drop of cyano adhesive, which will be drawn in by capillary action and harden the area.

Larger areas can be cut back and a wedge shaped patch inserted as in 22:2. Indentations up to 1/2in. across can be cut out with a hole-punch and new wood punched from scrap sheet and inserted in its place, all as shown in sketch 22:3.

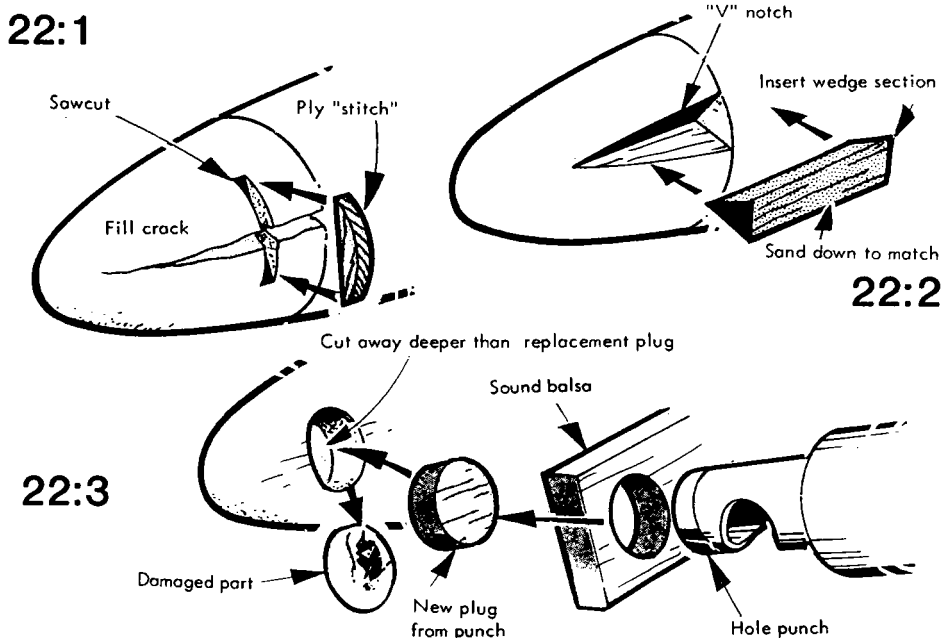

Sheet fuselages can be patched inside a cracked or split area, but beware of having a sudden step at the edges of such a 'doubler' patch. This will promote a further weak point. Chamfer the edges off, but in doing so, avoid a 'knife-edge' to the patch, or it may curl away at the edge as in 22:4. Finish the chamfer after gluing, as in 22:5. Medical bandage and white glue can make a sound repair inside and such treatment takes up little space.

Damage to leading edge sheet is a common happening. Provided the leading edge strip is intact, a new piece may be let in. Guess at the area required as in 22:6, pin the patch in place and cut both patch and ragged edge to match as in 22:7, finally insert support strips cut from cross-grain strips as in 22:8. When these are set, glue in the patch which should now fit. The sheet from which the patch is cut should be of similar hardness and flexibility to the wood it replaces, otherwise the camber may be changed. Sometimes the damaged sheet can be pushed straight from below, provided that access can be gained via a small hole. Cyano then can be used on the repair.

It may be found that a rib or riblet has been crushed, or the leading edge strip broken. In this case, repairing the sheet alone will leave a weak area.

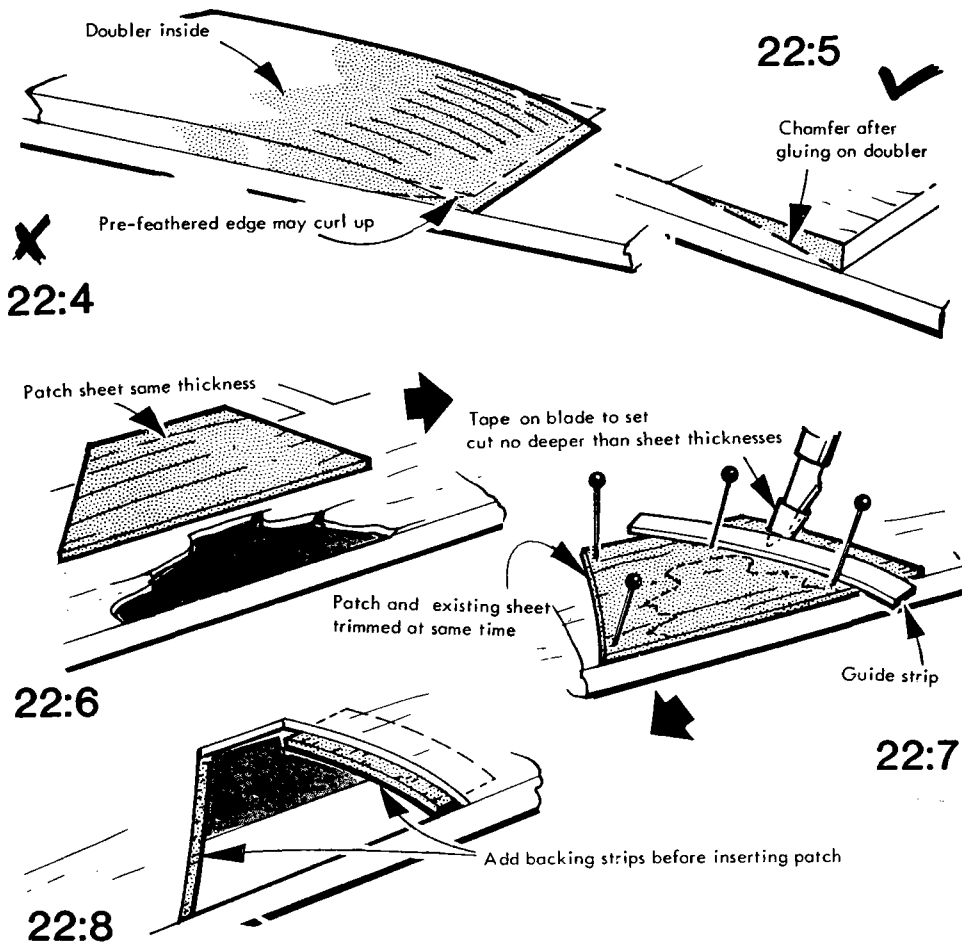

Lightweight models can have new pieces of rib and leading edge joined in by making simple scarf or 'V' joints as in 22:9. Note how the new piece extends well into the supported area near the spars, and in the leading edge, towards the next ribs. Thin splints each side of a damaged spar will restore some strength. Beware of the model that is heavy, or if radio controlled and subject to more stress than a light free-flight machine: repairs to vital structural members could be dangerous. Far safer to rebuild that whole panel or section of tail-boom. More will be at risk than a slow flying free-flight model. Radio models are heavier, faster, have larger engines and are sometimes flown near other models and people. Sudden loss of control through structural failure could result in an accident, besides risking the radio equipment itself.

Open frame models having tissue covering can be temporarily repaired on the spot when the covering gets torn locally. The doped surface is fairly stiff and can be coaxed back into place with a pin as in 22:11. Balsa cement shrinks the edges together as it sets. The result is not pretty, but maintains strength until a neat repair can be done at home. This will entail cutting a neat patch and trimming away the damaged tissue, so that there is a small overlap around the edges. Where it is practical to repair a small area in the centre of a bay between

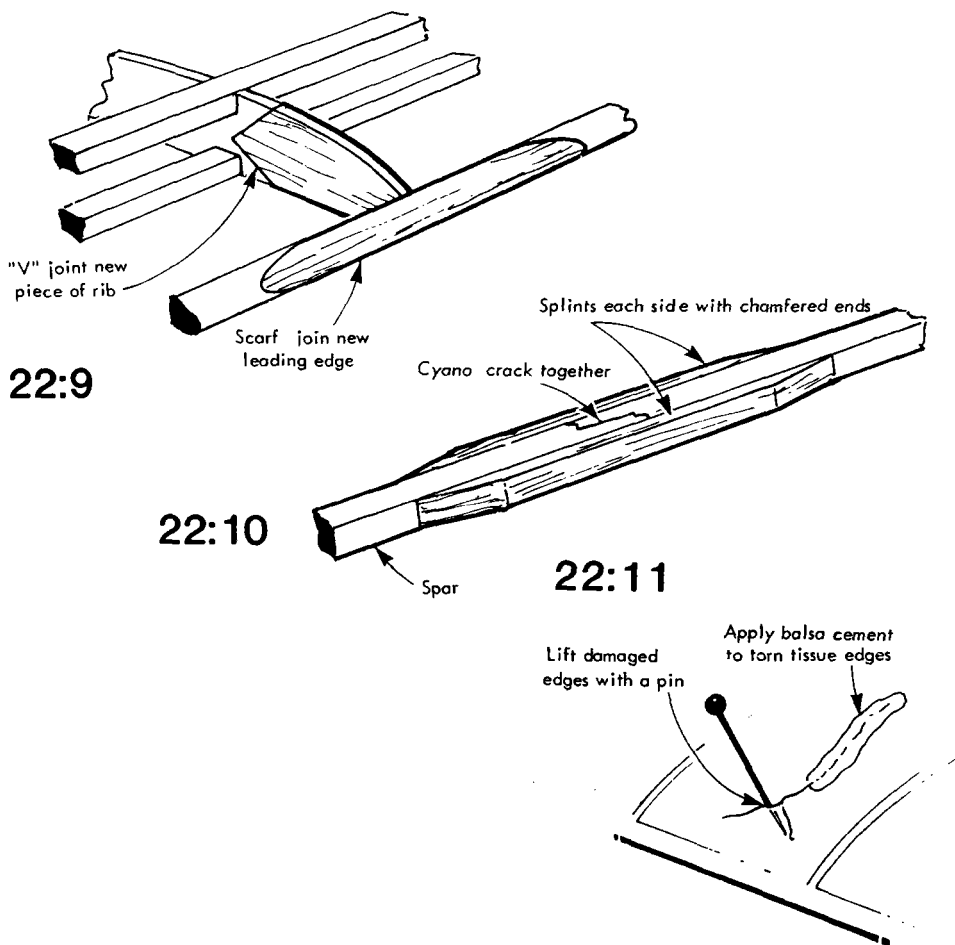

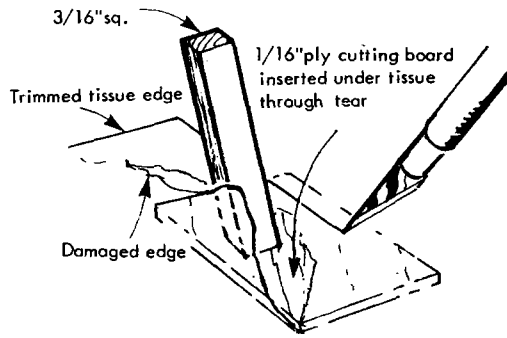

22:12

ribs and spars, a clean trimming cut can be aided by inserting a small ply 'cutting board' as in 22:12. Otherwise cut back to the nearest rib or spar and patch that area.

Finally, never attempt to repair foam wings near the centre, particularly if the model is radio controlled. Once crumpled, the foam is difficult to rejoin and the veneer, which is the main structural part, may have nothing to support it. Further out on the wing, new sections of core can be spliced in with vertical spanwise reinforcement webs inserted in sawcuts made vertically in the core. The new veneer edges can then be reinforced with *epoxy* and light glassfibre cloth. Remember that such a repair adds weight and the wing will need balancing with a small tip weight in the opposite wing.

Do not forget to fuel-proof the surface of any repair if it is made to a previously proofed part of the model. Fuel may have already soaked into the wood at the moment of crash so before using adhesives, soak the offending part in cleaning fluid such as 'Thawpitt' and blot away the oil. If wood is slightly moist from water then cyano glue can bond, but oil and grease are a barrier to most glues.

# CHAPTER 23

## Workshop tips

**Planning a workspace**  
**Bench and boards**  
**Building aids**  
**Storage**  
**Field kit**

It will not be long before that which started as 'kitchen table modelling' becomes ousted from the kitchen . . . Sawdust never was a good garnish for cooking and gravy spoils a paint finish.

In the interests of safety, for both models and small children, aeromodelling is best done in a small bedroom, boxroom, or sound, dry and properly heated and ventilated shed. The plan shown in sketch 23:1 shows how to spread your modelling wings, in a space about 7ft x 11ft. Modelling benches *can* be condensed into smaller spaces, which can be shut away, such as in a double wardrobe space or alcove at the side of a chimney. For heavy work a 'Workmate' folding bench can be used temporarily and fitted with a metal working vice in addition to its

23:1

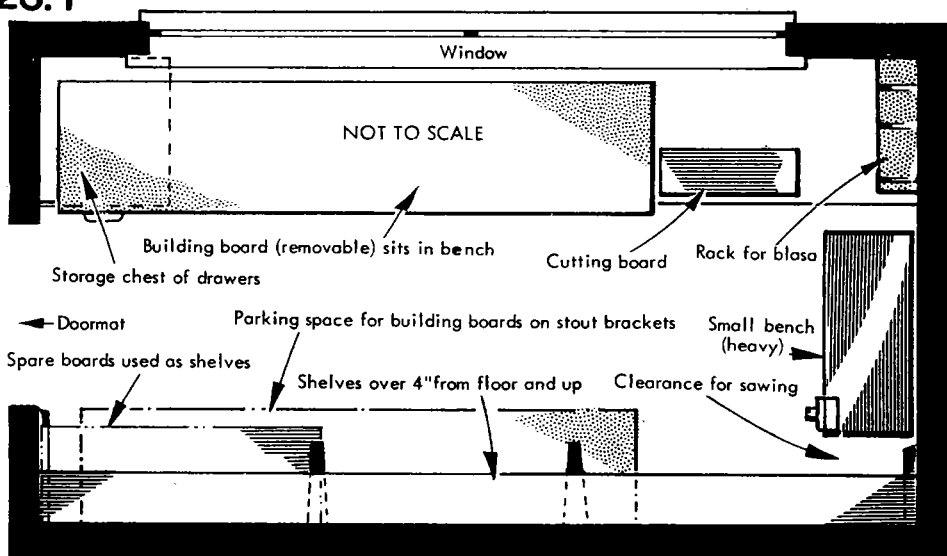



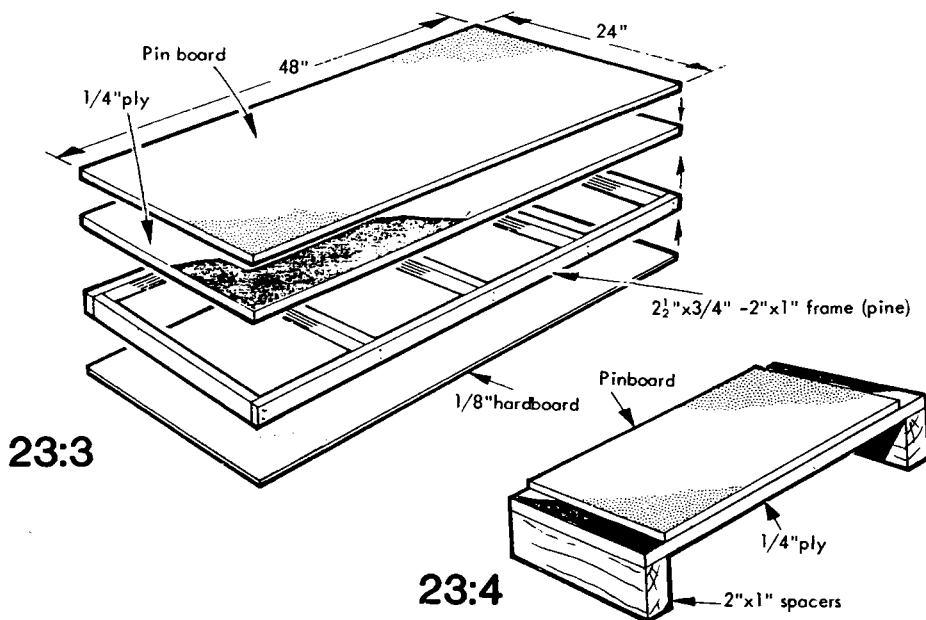
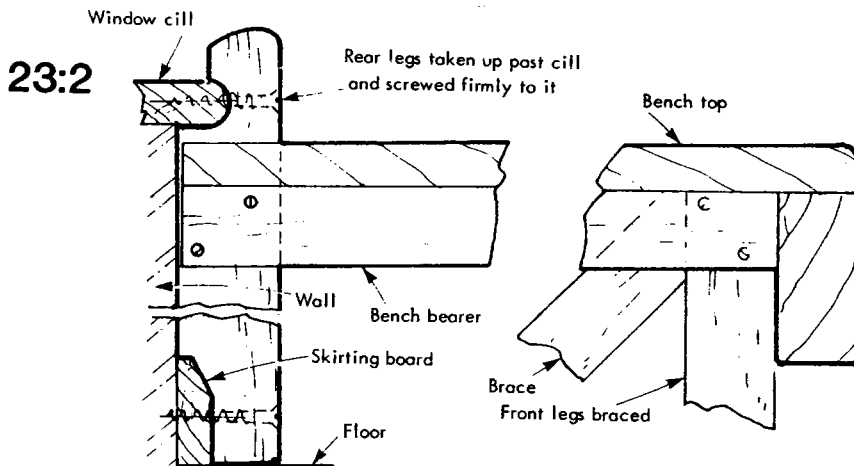

own. Some storage space is important for keeping small building boards with part-constructed model components upon them, while building is interrupted for such mundane things as work and domestic activities.

Above all, the modeller's 'holy of holies' needs to be locked safely away from inquisitive small fingers.

Quite a small 'heavy work' bench will suffice. The most arduous task it serves is for the light metalwork involved in forming thick piano wire parts and a little woodwork involved in making plywood parts. More experienced or experimental modellers tend to demand more bench area for work, which could well be done in the space where a removable building board sits.

Now to fix a bench . . . Modern houses tend to have light cellular block walls, so anything needing a firm attachment requires the use of toggle bolts. An alternative is to utilise the windowsill and skirting board

as a means of attachment, as in 23:2. The bench top does need to be firm for it needs to support the vice. A lightly secured vice is worse than a badly made vice.

The building board itself must be firm and flat. If there is no firm table for it, then use a ready made domestic flush door for the board, or make one, as sketch 23:3. Note the pin-board surface (D.I.Y. shops or the woodyard). The board should be about 24 x 48in., but smaller will suffice (14 x 40in.) in which case try some mini boards as in 23:4 . . . some of these, in addition, can be stacked to save space without disturbing the parts like tailplanes which they carry.

Another useful board is the dihedral board. This can be made from blockboard surfaced with pinboard and hinged flush, so that wings can be built in one piece in one session. The dimensions are typical, but depend on the largest wing one is likely to be building in this way. (23:5). They are also useful at the doping stage.

To ease the accurate construction of fuselages (and in some cases other components) a building jig can prove an asset. The one designed for making oneself is shown in 23:6. Being magnetic, it is instantly set up for width and angle. Low cost magnets are available from Proops or Whistons Ltd. One of the wood support blocks can be used to collect stray pins if placed in a plastic bag. When collected, the pins are retained in the bag which is turned inside-out in removing the magnet-carrying block.

The block can also be stood on the jaws of a vice as a drilling guide (useful if the workshop has no drill stand).

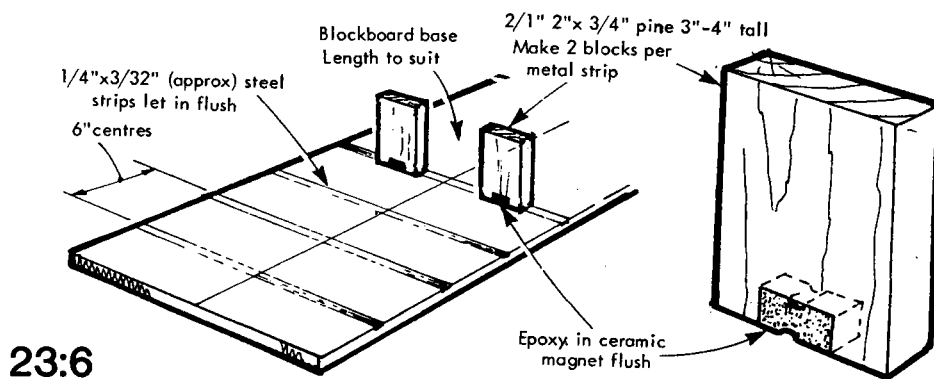
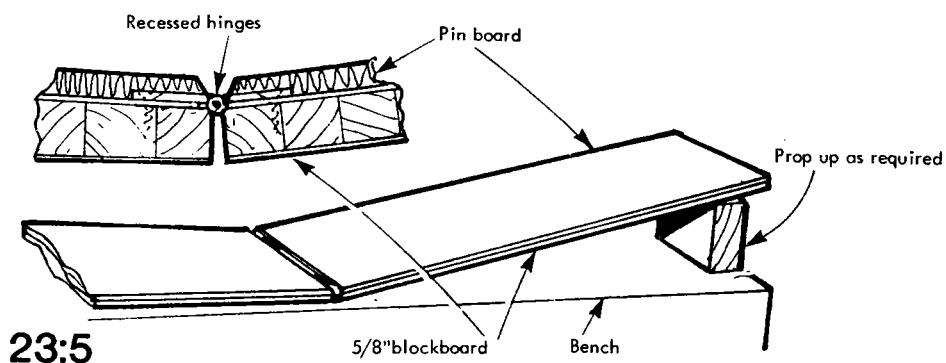

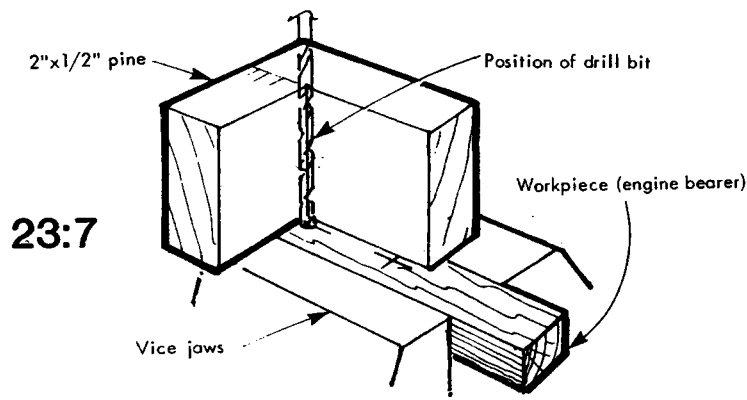

An 'L'-shaped wood block also serves to guide a drill bit in a hand drill as in 23:7. The block is placed in line with the hole and the bit guided by the inner angle of its sides.

Storage of the many tiny nuts, bolts and screws, R/C accessories, wheel collets, washers and tiny useful offcuts of tube and metal sections, can be distracting to the eye and memory. Empty film containers (35mm type) are easily collected from photographers and friends, and make excellent containers for small items. A rotating rack 13in. long will hold about 36 containers – see sketch 23:8. Remove each container from the underside row to avoid spilling the contents.

Larger items and hand tools can be kept in a neat folding wall cupboard, built as in 23:9, and sized according to the user's needs with a maximum of say 6ft. wide by 2ft. tall and 6in. deep when open (12in. deep closed x 3ft. long). Use hardboard or  $\frac{1}{8}$ in. ply and  $\frac{1}{2}$ in. thick wood for the shelves on small versions, up to  $\frac{3}{4}$ in. thick for the largest.

If you want to grade balsa wood into comparative hardness or to weigh small components, try the simple multi-purpose Balsa Tester in 23:10.

## Tools

Basic aeromodelling can be done with few hand tools, but collect a good range of modelling knife blades. For carving, use a firm blade knife, kept impeccably sharp and use a 'Stanley' type knife for work on thin ply. A razor saw is neat to use, but reserve it for balsa, Junior hacksaws and larger will also be needed, so will a modelling plane for balsa and a small carpenter's plane for shaping hardwood strip.

If it can be afforded, a modeller's mini drill and stand is a great asset, so is a disc sander, for producing accurate ends for jointing.

As was shown in the wirework part of Chapter 13, do not expect small needle-nose pliers to cope with piano wire of greater thickness than 18s.w.g. . . . The same applies to cutting the wire.

One cannot have too large a selection of drill bits, but go gently with those under  $\frac{1}{32}$ in. dia. This list is by no means exhaustive and closes with a vital item . . . *Face Masks*. Balsa dust is unpleasant to inhale, yet

it is so light that without a mask and appropriate filter pad, it floats in like smoke. Glassfibre dust is **BROKEN GLASS** and some paint finishes are toxic . . . You want to enjoy the flying bit, don't you?

This is not going to stop you modelling, though. Treat the dust and fumes with the same respect as the scalpel blades used in cutting balsa . . . If there is much sanding to be done, take it outside when the weather permits.

### Outward and onward

Modellers have been known to turn up at the flying site with their tool kit and spares in a plastic carrier bag or bucket. A simple 'field box'

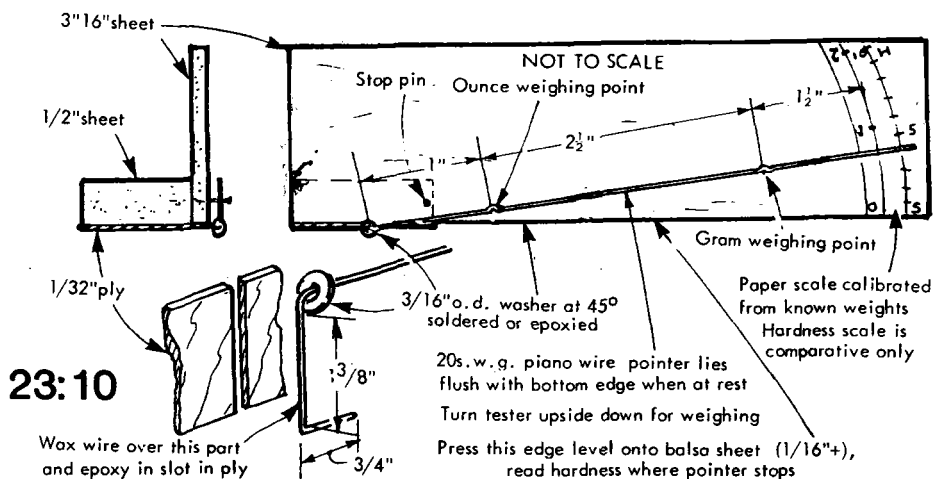
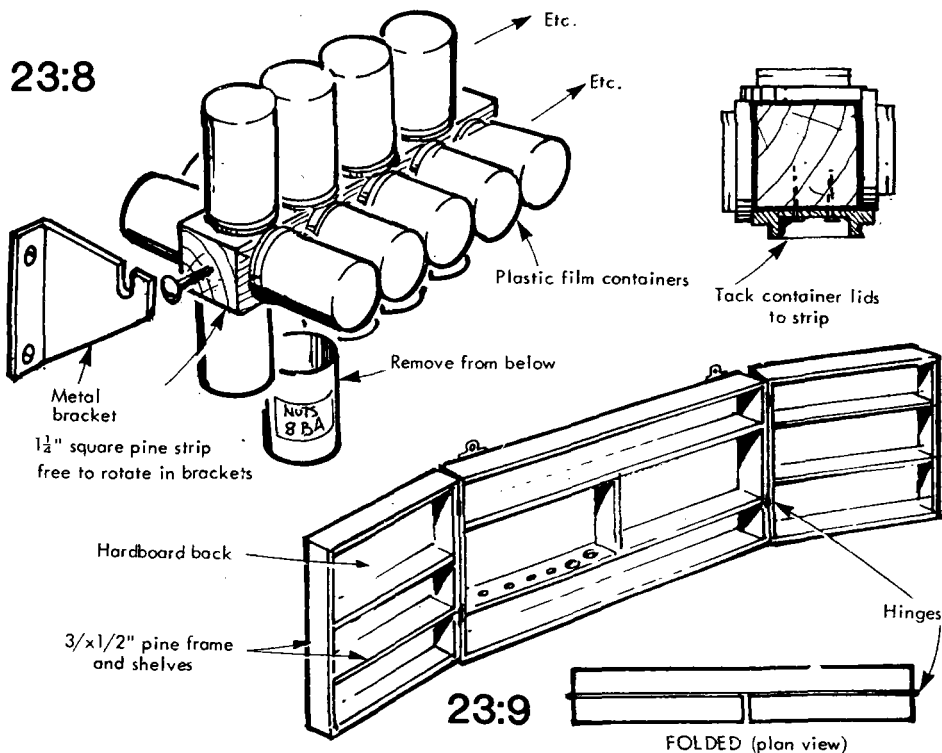

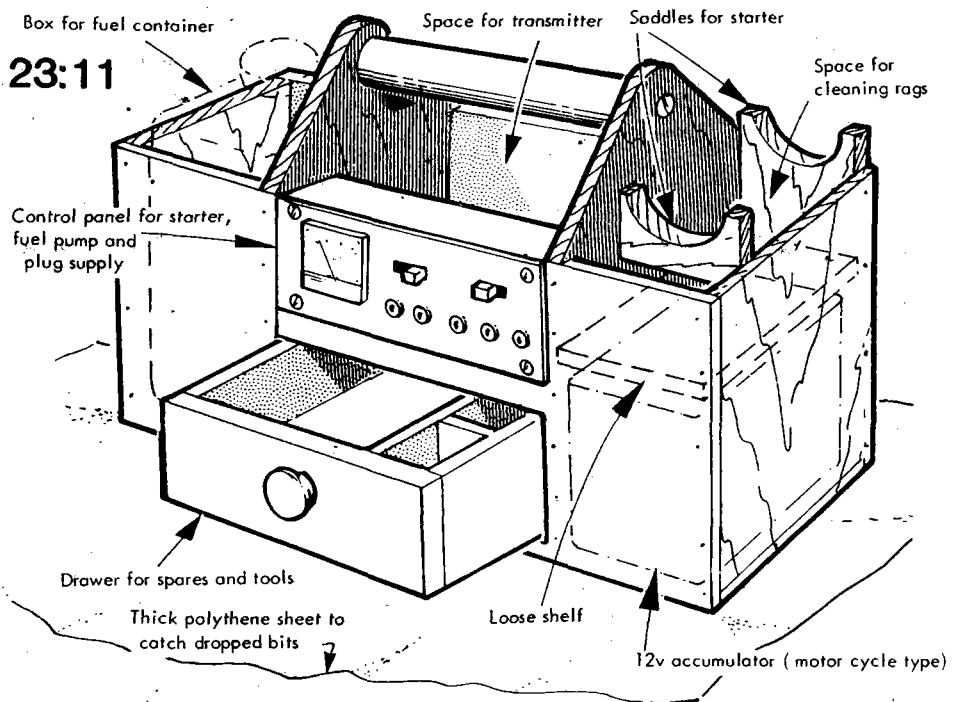

such as that in 23:11 is not difficult to make and reflects the care you put into building the models.

As more and more models are built, proven, enjoyed and remembered, you may find your own ways of making building easier. Develop new model designs . . . Share the enjoyment.

The Argus Specialist Publications range of modelling magazines could be interested in well proven and nicely presented designs. They even pay for those photographs and plans accepted for publication. Don't forget a S.A.E. though . . . **HAPPY AEROMODELLING.**